

# Homestyle Frontload Washers

Refer to Page 5 for Model Numbers

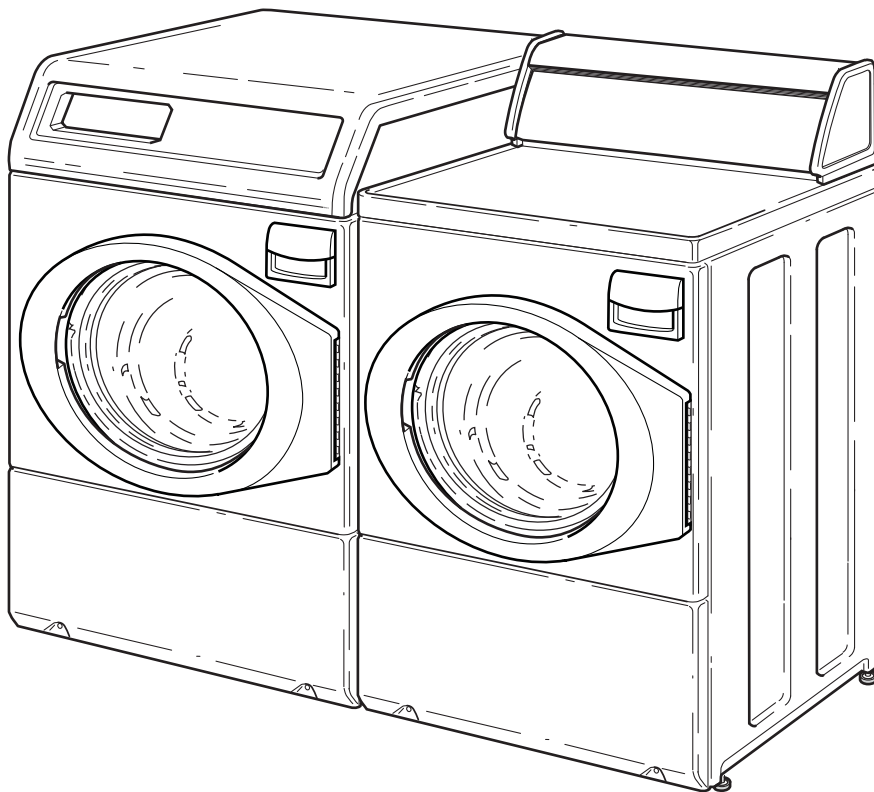

FLW2406N

— Troubleshooting —



# Table of Contents

<b>Section 1 – Safety Information .....</b>	<b>2</b>
Locating an Authorized Servicer.....	3
<b>Section 2 – Introduction .....</b>	<b>4</b>
Customer Service.....	4
Serial Plate Location.....	4
Model Identification .....	5
Theory of Operation .....	6
<b>Section 3 – General Troubleshooting .....</b>	<b>7</b>
1. Testing Mode Keypad Combinations .....	7
2. Factory Test Procedure .....	13
3. Motor Circuit.....	19
4. Dipswitch Configuration.....	20
5. Troubleshooting Knocking Noise .....	21
6. Explanation of LEDs on Drive Control .....	21
7. Door Fails to Unlock at End of Cycle.....	21
8. No Spin .....	21
9. Excessive Vibration and/or Noise During Spin.....	23
10. Excessive Cycle Time.....	24
<b>Section 4 – Electronic Control Troubleshooting.....</b>	<b>25</b>
11. Error Codes .....	25
12. No keypad Function.....	32
13. No Visible Display on Control.....	33
14. Washer Will Not Start – “do” Displayed.....	35
15. Washer Will Not Start – “Er”, “dl” on Display .....	37
16. Washer Will Not Fill (Machine Empty, No “Er”, “PS” on Display).....	39
17. Washer Overflows.....	41
18. Pump or Drain Valve Does Not Operate .....	43
19. Motor Does Not Run (“Ed”, “29” on Display) .....	45
20. Washer Will Not Heat (Models Equipped with Heater) (“Er”, “oP” or “Er”, “SH” Displayed) .....	47
21. Washer Will Not Heat (Models Equipped with Heater) .....	49
<b>Section 5 – Adjustments .....</b>	<b>51</b>
22. Cabinet Leveling Legs .....	51
23. Loading Door .....	52
24. Motor Belt Tension .....	53
25. Door Catch .....	54
<b>Section 6 – Cycle Sequence Charts.....</b>	<b>56</b>

© Copyright 2016, Alliance Laundry Systems LLC

All rights reserved. No part of the contents of this book may be reproduced or transmitted in any form or by any means without the expressed written consent of the publisher.

# Section 1

## Safety Information

Throughout this manual and on machine decals, you will find precautionary statements (“CAUTION,” “WARNING” and “DANGER”) followed by specific instructions. These precautions are intended for the personal safety of the operator, user, servicer, and those maintaining the machine.

### **DANGER**

Danger indicates an imminently hazardous situation that, if not avoided, will cause severe personal injury or death.

### **WARNING**

Warning indicates a hazardous situation that, if not avoided, could cause severe personal injury or death.

### **CAUTION**

Caution indicates a hazardous situation that, if not avoided, may cause minor or moderate personal injury or property damage.

Additional precautionary statements (“IMPORTANT” and “NOTE”) are followed by specific instructions.

### **IMPORTANT**

The word “IMPORTANT” is used to inform the reader of specific procedures where minor machine damage will occur if the procedure is not followed.

### **NOTE**

The word “NOTE” is used to communicate installation, operation, maintenance or servicing information that is important but not hazard related.

In the interest of safety, some general precautions relating to the operation of this machine follow.

	<h2>WARNING</h2>
<ul style="list-style-type: none"><li>• <b>Failure to install, maintain and/or operate this product according to the manufacturer’s instructions may result in conditions which can produce serious injury, death and/or property damage.</b></li><li>• <b>Do not repair or replace any part of the product or attempt any servicing unless specifically recommended or published in this Service Manual and unless you understand and have the skills to carry out the servicing.</b></li><li>• <b>Whenever ground wires are removed during servicing, these ground wires must be reconnected to ensure that the product is properly grounded and to reduce the risk of fire, electric shock, serious injury or death.</b></li></ul>	
<small>W006R2</small>	

**WARNING**

To reduce the risk of electric shock, fire, explosion, serious injury or death:

- Disconnect electric power to the washer before servicing.
- Never start the washer with any guards/panels removed.
- Whenever ground wires are removed during servicing, these ground wires must be reconnected to ensure that the washer is properly grounded.
- Motor not grounded! Disconnect electric power before servicing motor.

W485

**WARNING**

Repairs that are made to your products by unqualified persons can result in hazards due to improper assembly or adjustments subjecting you, or the inexperienced person making such repairs, to the risk of serious injury, electrical shock, or death.

W007

**WARNING**

If you or an unqualified person perform service on your product, you must assume the responsibility for any personal injury or property damage which may result. The manufacturer will not be responsible for any injury or property damage arising from improper service and/or service procedures.

W008

**NOTE: The WARNINGS and IMPORTANT INSTRUCTIONS appearing in this manual are not meant to cover all possible conditions and situations that may occur. Common sense, caution and care must be exercised when installing, maintaining or operating the washer.**

Always contact your dealer, distributor, service agent or the manufacturer about any problems or conditions you do not understand.

### Locating an Authorized Servicer

Alliance Laundry Systems is not responsible for personal injury or property damage resulting from improper service. Review all service information before beginning repairs.

Warranty service must be performed by an authorized technician, using authorized factory parts. If service is required after the warranty expires, Alliance Laundry Systems also recommends contacting an authorized technician and using authorized factory parts.

# Section 2

## Introduction

### Customer Service

If literature or replacement parts are required, contact the source from whom the machine was purchased or contact Alliance Laundry Systems at (920) 748-3950 for the name and address of the nearest authorized parts distributor.

For technical assistance, call either of the numbers listed below:

(920) 748-3121 Ripon, Wisconsin

+32 56 41 20 54 Wevelgem, Belgium

### Serial Plate Location

When calling or writing about your product, be sure to mention model and serial numbers. Model and serial numbers are located on Serial Plate as shown.

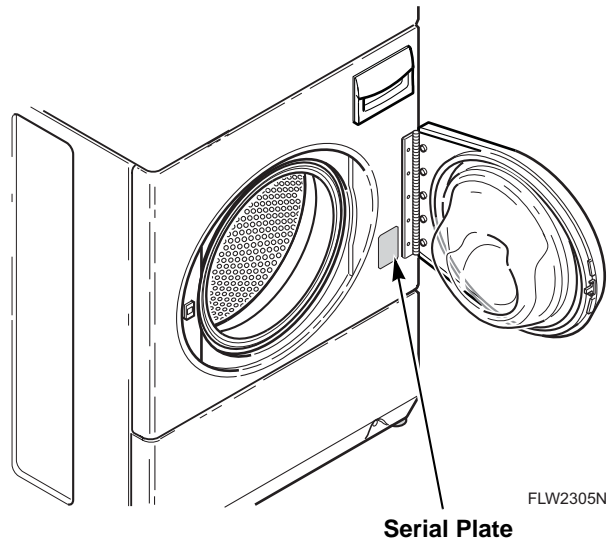

## Model Identification

Information in this manual is applicable to these washers.

AFBE9BSP303NN29	AFNE9BSP543DW01	LFNE5BSP543ZW01
AFBE9BSP303NW29	AFNE9BSP543ZN01	LFNE5RSP113CW01
AFNE9BSP113CN01	AFNE9RSP113TW01	LFNE5RSP113FW01
AFNE9BSP113CW01	BFNE6BJP113CW01	LFNE5RSP113TW01
AFNE9BSP113FN01	BFNE6BJP113TW01	LFNE5RSP303NW22
AFNE9BSP113TN01	FFNE5RSP303NW10	PFNE3BJP113TG01
AFNE9BSP113TW01	LFNE5BJP113CW01	PFNE3RSP113TG01
AFNE9BSP123DN01	LFNE5BJP113TW01	PFNE3RSP303AG01
AFNE9BSP123DW01	LFNE5BSP113CW01	UFNE5BJP113TW01
AFNE9BSP303AN01	LFNE5BSP113FW01	UFNE5BJP113TW08
AFNE9BSP303AW01	LFNE5BSP113JW01	YFNE5BJP113CW01
AFNE9BSP303HN01	LFNE5BSP113TW01	YFNE5BJP113TW01
AFNE9BSP303NN22	LFNE5BSP113ZW30	YFNE5RSP113CW01
AFNE9BSP303XN26	LFNE5BSP303AW01	YFNE5RSP113TW01
AFNE9BSP303XN34	LFNE5BSP303AW12	ZFNE9BSP113CN01
AFNE9BSP303XW26	LFNE5BSP303NW35	ZFNE9BSP113CW01
AFNE9BSP303XW34	LFNE5BSP303ZW01	ZFNE9BSP113FN01
AFNE9BSP543DN01	LFNE5BSP543NW23	ZFNE9BSP113FW01

## Introduction

# Theory of Operation

### General

This frontload washer provides some of the same principles of operation as the typical topload washers. It senses water level, it dispenses the desired laundry detergent, agitates the clothes for good cleaning action, removes the water out of the washer and spins the clothing in preparation for the dryer.

The difference in operation is primarily the rotational washing agitation created for the horizontal basket and drum. This agitation tumbles the clothes in a clockwise, pause, and counter-clockwise direction. This reversing tumbling action provides an efficient washing process and requires less laundry detergent and less water.

The cycle begins by locking the loading door after the vend is satisfied. The type of cycle and water temperature are determined by the appropriate pads on the electronic control.

The inner basket starts agitating during the wash water fill. A column of air is trapped in a pressure bulb and hose. The air pressure continues to increase as the inner basket fills with water with the pressure sensor monitoring the water level.

The agitate step tumbles the clothing in a clockwise direction for a period of time, pauses for a period of time and then tumbles the clothing in a counterclockwise direction for a period of time. This agitation continues until the end of the wash cycle. The machine then stops agitating and turns on the pump or drain valve which removes the wash water.

Upon completion of the wash cycle, the machine goes into a rinse cycle. Fresh cold water is brought into the inner basket via the mixing valve until the fill level is satisfied. The rinse cycle consists of agitation for a predetermined amount of time then a spin mode with the pump running where the machine goes into a series of spins.

After all the rinse cycles have been completed, the washer goes into a final spin cycle to extract as much water as possible from the clothing to prepare them for the dryer. The spin speeds and duration of this final spin cycle are determined by the type of wash cycle selected.

**NOTE: Washer may not reach 1200 RPM because of an out-of-balance condition. Control may limit speed to 1000, 800, 650 or 500 RPM depending on severity of out-of-balance condition.**

### Technical

The basic operational system of this washer consists of the electronic control, the inverter control, pressure sensor, water valves, electric pump (or drain valve) and A.C. motor.

The electronic control performs all control and timing functions. The electronic control sends simple speed and output commands to the inverter control via serial communication. The drive control powers the door lock, pump (or drain valve), motor, water valves and heater (if equipped).

The drive control powers the A.C. motor and performs all motor control functions. The drive control also powers the water valves, dispenser valves and door lock. The drive control is powered through the door switch and electronic control. The drive control also alerts the electronic control to any errors in the motor.

Before entering any spin step the drive control measures out-of-balance. The drive control will try to redistribute the clothes if an out-of-balance condition exists by limiting the spin speed to several speeds depending on the severity of the out-of-balance condition. If the out-of-balance condition is severe enough the drive control will limit speed to 90 RPM and will not spin.

**NOTE: An additional out-of-balance switch is used to detect any out-of-balance condition during spins. If this switch opens during a spin step, the drive control immediately stops and then restarts the spin.**



# Section 3

## General Troubleshooting



### WARNING

To reduce the risk of electric shock, fire, explosion, serious injury or death:

- Disconnect electric power to the washer before servicing.
- Never start the washer with any guards/panels removed.
- Whenever ground wires are removed during servicing, these ground wires must be reconnected to ensure that the washer is properly grounded.
- Motor not grounded! Disconnect electric power before servicing motor.

W485

### 1. Testing Mode Keypad Combinations

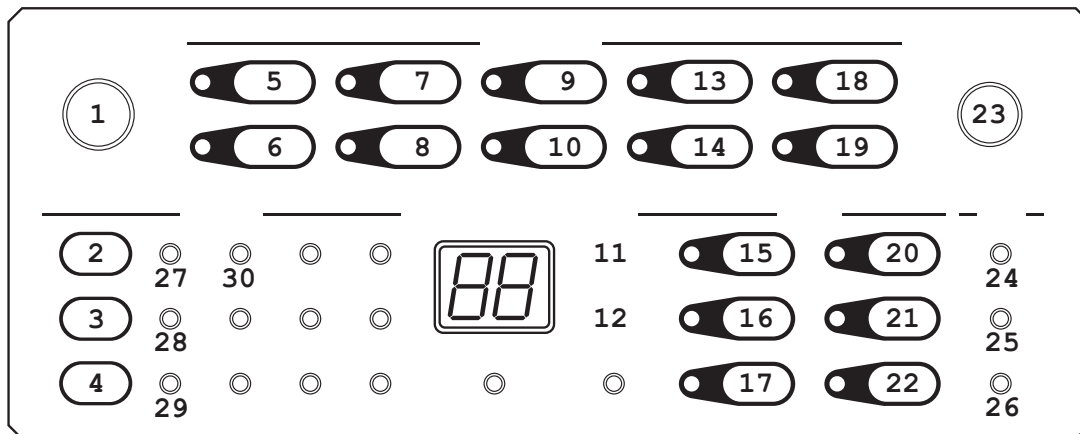

FLW1830S

Figure 1



## WARNING

**To reduce the risk of electric shock, fire, explosion, serious injury or death:**

- **Disconnect electric power to the washer before servicing.**
- **Never start the washer with any guards/panels removed.**
- **Whenever ground wires are removed during servicing, these ground wires must be reconnected to ensure that the washer is properly grounded.**
- **Motor not grounded! Disconnect electric power before servicing motor.**

W485

### Testing Mode Keypad Entry

Function	Keys	Entry State
Enter/Exit Audit Display Mode	3+9	Start Mode
Enter/Exit Drive Version Display Mode	3+14	Start Mode
Enter/Exit Extra Water Mode	8+14	Start Mode and Default/Extra Water Dipswitch On
Enter/Exit Factory Test Counter Display Mode	2+9	Start Mode
Toggle Keypad Acknowledgment	13+14	Start Mode
Turn On/Off Rainbow Pizzazz Display	9+10	Start Mode
Rapid Advance Through Current Cycle Step	7+13	Run Mode
Enter/Exit Show Mode	3+8	Start Mode
Enter/Exit Spin Retry Extra Time Toggle Mode	8+13	Start Mode and powered for less than 5 minutes.
Enter/Exit Software Version Display Mode	7+8	Start Mode
Toggle Suds Extra Time Mode	2+3	Start Mode and powered for less than 5 minutes
Enter/Exit Water Level Display Mode	4+14	Any Mode except if Control Lock is On
Enter Factory Test Mode	2+7	Start Mode and powered for less than 5 minutes

Table 1

### Audit Display Mode

The control has a two byte cycle audit counter. This counter is incremented at the end of every cycle. If a cycle finishes prematurely due to an error condition or cycle termination due to a Power/Cancel input the cycle counter will not be incremented.

While in Start Mode, enter by pressing both keypads 3 and 9. Refer to *Figure 1*.

The control will display the most significant two digits of the cycle audit counter, then the middle two digits and then the least significant two digits in one second intervals. All three sets of digits are displayed regard-

less of the cycle audit counter value. The cycle counter has a maximum value of 65,535. The two most significant digits will be accompanied by LED number 24, the middle two digits will be accompanied by the LED 25, and the two least significant digits will be accompanied by LED 26. This counter will cycle continuously while in this mode. To exit this mode, either press the two keypads used to enter it, press the Power/Cancel key, or unplug the machine.

The drive will be enabled at all times in this mode if the door is closed.



## WARNING

To reduce the risk of electric shock, fire, explosion, serious injury or death:

- **Disconnect electric power to the washer before servicing.**
- **Never start the washer with any guards/panels removed.**
- **Whenever ground wires are removed during servicing, these ground wires must be reconnected to ensure that the washer is properly grounded.**
- **Motor not grounded! Disconnect electric power before servicing motor.**

W485

### Drive Version Display Mode

The control has the ability to display the revision of the software on the drive board. This mode displays “db” and then the current software version number as “XX”, where “XX” is the control software version number, with each display showing for two (2) seconds. All LEDs are off while in this mode. If the version shows up as 00, either the communication to the drive has not started yet or there is a problem with communication with the drive.

While in Start Mode, enter by pressing both keypads 3 and 14. Refer to *Figure 1*. To exit this mode, either press the two keypads used to enter it, press the Power/Cancel key, or unplug the machine.

### Extra Water Mode

This mode is used to increase the water fill levels for the machine by offering greater flexibility to the user. To enter this mode, first power down the control, set the Default/Increased Water Level dipswitch to ON, and power up the control. Then while in Start Mode, press both keypads 8 and 14 to enter Extra Water Mode. Refer to *Figure 1*.

Once in Extra Water Mode, the 7-segment displays will show the additional fill level where 00 is 0 inches of additional water, 05 is 0.5 inches of additional water, 10 is 1.0 inch of additional water, and so on. To change the value of the additional water level, press keypad 3 to increment the fill level by 0.5 inches. The maximum value is 2.0 inches. Pressing keypad 3 once more will reset the level to 0 inches.

To exit this mode and save the additional level, press keypads 8 and 14 again or press the Power/Cancel key. The additional inches of water can be disabled by setting the value back to 00 or by changing the dip switch to OFF and cycling power.

### Factory Test Counter Display Mode

The control has a two byte cycle factory test counter. This counter is incremented at the end of every factory test. If Factory Test finishes prematurely, the factory test counter will not be incremented.

While in Start Mode, enter by pressing both keypads 2 and 9. Refer to *Figure 1*.

The control will display the most significant two digits of the factory test counter then the middle two digits then the least significant two digits in one second intervals. All three sets of digits are displayed regardless of the factory test audit counter value. The factory test counter has a maximum value of 65,535. The two most significant digits will be accompanied by LED number 24, the middle two digits will be accompanied by the LED 25, and the two least significant digits will be accompanied by LED 26. This counter will cycle continuously while in this mode. To exit this mode, either press the two keypads used to enter it, press the Power/Cancel key, or unplug the machine.

### Keypad Acknowledgment

Pressing both keypads 13 and 14 will enable or disable the audio for when keys are pressed. Disabling will silence the beep audio each time a key is pressed, unless it is an invalid selection. Then a keypad error tone will still sound.



### WARNING

**To reduce the risk of electric shock, fire, explosion, serious injury or death:**

- **Disconnect electric power to the washer before servicing.**
- **Never start the washer with any guards/panels removed.**
- **Whenever ground wires are removed during servicing, these ground wires must be reconnected to ensure that the washer is properly grounded.**
- **Motor not grounded! Disconnect electric power before servicing motor.**

W485

## Rainbow Pizzazz Display

The control enters Idle Recovery Mode if the Power/Cancel keypad is pressed in while in Idle Mode. If the Idle Recovery Rainbow Pizzazz Display is set to ON, it will run for one second. If the Rainbow Pizzazz Display is set to OFF, the control will go directly to the mode that it was in before Idle Mode.

Once the Rainbow display is finished, the control will enter the mode it was in previous to entering Idle Mode, with the same settings that were previously selected, unless the previous mode was End of Cycle Mode. If the previous mode was End of Cycle Mode, Idle Mode, Idle Recovery Mode, or Non-Fatal Error Mode, then Start Mode will be entered. If any keypad is pressed while showing the Rainbow Pizzazz Display, the control will immediately enter the mode it was in previous to entering Idle Mode without the key being acted upon.

The Rainbow Pizzazz Display can be turned on or off by pressing keypads 9 and 10 while in Start Mode. Refer to *Figure 1*. On power fail, the control remembers whether the Rainbow Pizzazz Display was set to on or off.

## Rapid Advance

For Rapid Advance press keypads 7 and 13 at the same time to advance to the next step of the cycle. Each time these keypads are pressed the cycle will advance to the next step. Then press them both again to advance through the cycle. Refer to Cycle Sequence Charts section for each cycle step.

## Show Mode

Show Mode is a routine that shows each cycle for one second clockwise through the cycles. If any keypad is pressed while in Show Mode, the control will restore all user selections back to the factory defaults and enter a Simulated Programming Mode that allows a user to press keypads as if they were programming a machine cycle. The machine will not physically start if the Start/Pause keypad is pressed. Instead, if the Start/Pause key is pressed, the control will simulate what the display would look like if the control was running the set cycle. This simulation happens accelerated at 100 times the

normal speed. If no keypad is pressed for one minute while not counting down time in Simulated Programming Mode, the control will exit Simulated Programming Mode and return to Show Mode with Child Lock off if it was on.

While in Start Mode, enter by pressing both keypads 3 and 8. Refer to *Figure 1*. The control will remain in Show Mode until these keys are pressed again. Upon exiting Show Mode, the control will enter Start Mode and restore all user selections back to the factory defaults.

If Delay Start Setup Mode is entered while in Simulated Programming Mode and no keys have been pressed for one minute, Delay Start Setup Mode will be cancelled and the control will return to Show Mode, showing each cycle for one second.

If Delay Start Mode is entered while in Simulated Programming Mode by pressing the Start keypad while in Delay Start Setup Mode, the Delay Start time will start counting down one hour per second. The control will return to Simulated Programming Mode when the Delay Start Time expires.

If the Power/Cancel keypad is pressed while in Simulated Programming Mode and Start Mode, the control will enter Idle Mode, but will not go to sleep. This allows the control to return to Show Mode if no keypad is pressed for one minute.

While cycling through the different cycles, Show Mode changes the options and modifiers to show a greater variety of settings.

The drive will not be enabled in this mode.



## WARNING

To reduce the risk of electric shock, fire, explosion, serious injury or death:

- Disconnect electric power to the washer before servicing.
- Never start the washer with any guards/panels removed.
- Whenever ground wires are removed during servicing, these ground wires must be reconnected to ensure that the washer is properly grounded.
- Motor not grounded! Disconnect electric power before servicing motor.

W485

### Spin Retry Extra Time Toggle Mode

The control has the ability to extend the time of a cycle during a spin when a load becomes unbalanced or is unable to reach high spin speeds due to water and/or suds. While in Start Mode and within five minutes of the control being powered up, press keypads 8 and 13. Refer to *Figure 1*.

While in Spin Retry Extra Time Toggle Mode, to Toggle the Spin Retry Time, press the Start/Pause key. The display will toggle between “SP” and either “on” or “oF” every second. Setting this to “on” will allow the step time to be paused for the amount of time used up to that point in the current step twice per spin step during a cycle if the unbalance switch is hit or an OBL check at 90 RPMs or 350 RPMs needs to restart the spin to rebalance the load. Additional OBL failures in the same cycle step will not pause the time but will still cause a restart of the spin. To exit this mode, either press the two keypads used to enter it, press the Power/Cancel key, or unplug the machine.

### Software Version Display Mode

The control has the ability to display the revision of the software on it. This mode displays the machine type (“FL”), and then the current software version number as “S-” then “XX”, where “XX” is the control software version number. Each display appears for two seconds. All LEDs are off while in this mode.

While in Start Mode, enter by pressing both keypads 7 and 8. Refer to *Figure 1*. To exit this mode, either press the two keypads used to enter it, press the Power/Cancel key, or unplug the machine.

### Suds Toggle Mode

The control has the ability to extend the time of a cycle to help eliminate suds. While in Start Mode and within five minutes of the control being powered up, press keypads 2 and 3 to enter this mode. Refer to *Figure 1*.

While in Suds Toggle Mode, to Toggle the Suds Pause Time press the Start/Pause key. The display will toggle between “Sr” and either “on” or “oF” every second. Setting this to “on” will allow the time to be paused during a cycle if a Suds Removal Routine is run. To exit this mode, either press the two keypads used to enter it, press the Power/Cancel key, or unplug the machine.

	WARNING
<p><b>To reduce the risk of electric shock, fire, explosion, serious injury or death:</b></p> <ul style="list-style-type: none"> <li>• <b>Disconnect electric power to the washer before servicing.</b></li> <li>• <b>Never start the washer with any guards/panels removed.</b></li> <li>• <b>Whenever ground wires are removed during servicing, these ground wires must be reconnected to ensure that the washer is properly grounded.</b></li> <li>• <b>Motor not grounded! Disconnect electric power before servicing motor.</b></li> </ul>	
W485	

**Water Level Display Mode**

The control will read the current water level. The display will show the water level least significant digits in 0.1 inch precision which will override any other display.

If the water level is a negative value, then the right most decimal point is lit. If the value is greater than or equal to 10.0 inches, LED number 24 will be lit. If the value is greater than or equal to 20.0 inches, LEDs 24 and 25

will be lit. If the value is greater than or equal to 30.0 inches, LEDs 24, 25 and 26 will be lit.

To exit this mode, the user can either press the two keys used to enter this mode, press the Power/Cancel key, or unplug the machine. This mode only overrides the display, the machine will continue running any other modes that it is in.

Value	Display	# 24 Light On?	# 25 Light On?	# 26 Light On?
4.5 inches	45	No	No	No
-3.2 inches	32.	No	No	No
12.4 inches	24	Yes	No	No
20.8 inches	08	Yes	Yes	No
42.9 inches	29	Yes	Yes	Yes

Table 2

	WARNING
<p><b>To reduce the risk of electric shock, fire, explosion, serious injury or death:</b></p> <ul style="list-style-type: none"> <li>• <b>Disconnect electric power to the washer before servicing.</b></li> <li>• <b>Never start the washer with any guards/panels removed.</b></li> <li>• <b>Whenever ground wires are removed during servicing, these ground wires must be reconnected to ensure that the washer is properly grounded.</b></li> <li>• <b>Motor not grounded! Disconnect electric power before servicing motor.</b></li> </ul>	
W485	

## 2. Factory Test Procedure

It is helpful to run the Factor Test Procedure first to diagnose the machine’s issue. This procedure tests all machine features and operations.

### To Enter Factory Test Procedure

1. Be certain control is in Start Mode and less than 5 minutes after powering control.
2. Press keypads numbered 2 and 7 at the same time. Refer to *Figure 1*.

3. When the control enters the Factory Test Procedure, it will display the first test step, Machine Type.
4. To advance through the sequence of test steps press the Start/Pause keypad (No. 23). Refer to *Table 3* for all tests in the Factory Test Procedure.

### To Exit Factory Test Procedure

To exit the Factory Test Procedure, refer to Exit column in *Table 3*.

## Factory Test Procedure Quick Reference Chart

NOTE: ES refers to the External Supply Outputs.

#	Display	Status LEDs Lit	Motor	Valves	Door	Pump	Dump	Exit*	Step
0	FL	None	Off	None	Unlocked	Off	Open	1	Control Type
1	XX	None	Off	None	Unlocked	Off	Open	1	Software Version #
2	HX	None	Off	None	Unlocked	Off	Open	1	Control Level
3	XX	None	Off	None	Unlocked	Off	Open	1	Dipswitch Value Display
4	XX	None	Off	None	Unlocked	Off	Open	1	Cycle Configuration
5	PX	Refer to Keypad Test section	Off	None	Unlocked	Off	Open	3	Keypad Test
6	88	All plus audio signal on high	Off	None	Unlocked	Off	Open	1	Show Mode
7	dO with door open dC with door closed	None	Off	None	Unlocked	Off	Open	10 And Then 1	Door Switch Test

Table 3 (continued)

General Troubleshooting



**WARNING**

To reduce the risk of electric shock, fire, explosion, serious injury or death:

- Disconnect electric power to the washer before servicing.
- Never start the washer with any guards/panels removed.
- Whenever ground wires are removed during servicing, these ground wires must be reconnected to ensure that the washer is properly grounded.
- Motor not grounded! Disconnect electric power before servicing motor.

W485

Table 3 (continued)

#	Display	Status LEDs Lit	Motor	Valves	Door	Pump	Dump	Exit*	Step
8	db	None	Off	None	Unlocked	Off	Open	10, 12 And Then 1	Drive Type
9	XX	None	Off	None	Unlocked	Off	Open	10, 12 And Then 1	Drive Version #
10	dL when door locks dU when door unlocks	None	Off	None	Locked	Off	Open	1 And 7	Door Lock Check Test
11	Cd	Wash	Off	Cold, Detergent, ES 1	Locked	Off	Closed	1	Cold, Detergent, Output 1
12	HS	Wash	Off	Hot, Softener, ES 2	Locked	Off	Closed	1	Hot, Softener, Output 2
13	PS	Wash	Off	Hot, Cold	Locked	Off	Closed	2 And Then 1	Pressure Sensor Fill
14	XX	None	Off	None	Locked	Off	Closed	1 Or 5	Heater Test
15	OF	Wash	Off	Hot, Cold, Detergent, Softener, ES 1, 2, 3, 4, Cycle Output	Locked	Off	Closed	8 And Then 1	Overflow
16	LA	Rinse	Low Agitate	ES 3, Cycle Output	Locked	Off	Closed	1	Low Agitate
17	rA	Rinse	Regular Agitate	ES 4	Locked	Off	Closed	1	Regular Agitate

Table 3 (continued)



	WARNING
<p><b>To reduce the risk of electric shock, fire, explosion, serious injury or death:</b></p> <ul style="list-style-type: none"> <li>• <b>Disconnect electric power to the washer before servicing.</b></li> <li>• <b>Never start the washer with any guards/panels removed.</b></li> <li>• <b>Whenever ground wires are removed during servicing, these ground wires must be reconnected to ensure that the washer is properly grounded.</b></li> <li>• <b>Motor not grounded! Disconnect electric power before servicing motor.</b></li> </ul>	
W485	

Table 3 (continued)

#	Display	Status LEDs Lit	Motor	Valves	Door	Pump	Dump	Exit*	Step
18	Pu for pump installed dr for gravity drain installed	Rinse	Off	None	Locked	On	Open	9	Pump/Gravity Drain
19	actual RPM	Spin	Factory Spin Profile	None	Locked	On	Open	1	Factory Spin
20	bA	Spin	Break-away Agitate	Hot, Cold, Detergent, Softener, ES 1, 2, 3, 4, Cycle Output	Unlocked	On	Open	1, 1 Again Then 4 Then 11	Breakaway
21	Pd	Spin	Off	None	Unlocked	Off	Open	13	Power Down

Table 3

**EXIT column key:**

- |   |  |
|---|--|
| <ul style="list-style-type: none"> <li>1-exit by Start/Pause keypress</li> <li>2-exit by fill level satisfaction</li> <li>3-exit when all keypads are pressed</li> <li>4-exit when door is unlocked</li> <li>5-exit when temp reaches 40°C</li> <li>6-exit when step timed out</li> <li>7-exit when door locks</li> </ul> | <ul style="list-style-type: none"> <li>8-exit when overflow level reached</li> <li>9-exit when drum is empty</li> <li>10-exit when door is closed</li> <li>11-exit when door is opened</li> <li>12-exit when drive communication is established</li> <li>13-exit when machine unpowered</li> </ul> |
|---|--|



## WARNING

To reduce the risk of electric shock, fire, explosion, serious injury or death:

- Disconnect electric power to the washer before servicing.
- Never start the washer with any guards/panels removed.
- Whenever ground wires are removed during servicing, these ground wires must be reconnected to ensure that the washer is properly grounded.
- Motor not grounded! Disconnect electric power before servicing motor.

W485

### Keypad Test

Upon entry into this test, the control will display “P-”. When a keypad is pressed the control will display “PX” where X is the keypad number referenced in *Table 4*. For keypads 10 and greater the control will display “XX” where XX is the keypad number. As each keypad is pressed, the nearest LED

will light up and remain lit for the duration of the keypad test. When all keypads have been pressed the control will automatically advance to the next step. Keypads that are not available on some controls do not need to be tested. Refer to *Figure 1* for keypad number and LED references.

### Keypad Numbers (some models may not have all keypads)

Display	Key Number	LED
P1	1	25
P2	2	27
P3	3	28
P4	4	29
P5	5	Next to keypad
P6	6	Next to keypad
P7	7	Next to keypad
P8	8	Next to keypad
P9	9	Next to keypad
10	10	Next to keypad
13	13	Next to keypad
14	14	Next to keypad
15	15	Next to keypad
16	16	Next to keypad
17	17	Next to keypad
18	18	Next to keypad
19	19	Next to keypad
20	20	Next to keypad
21	21	Next to keypad
22	22	Next to keypad
23	23	26

Table 4

	<h2 style="margin: 0;">WARNING</h2>
<p><b>To reduce the risk of electric shock, fire, explosion, serious injury or death:</b></p> <ul style="list-style-type: none"> <li>• <b>Disconnect electric power to the washer before servicing.</b></li> <li>• <b>Never start the washer with any guards/panels removed.</b></li> <li>• <b>Whenever ground wires are removed during servicing, these ground wires must be reconnected to ensure that the washer is properly grounded.</b></li> <li>• <b>Motor not grounded! Disconnect electric power before servicing motor.</b></li> </ul>	
W485	

### Dipswitch Value Display Test

This step displays the state of the Control Configuration Dip Switches in hex, where the least significant bit is Dip Switch #1 and the most significant bit is Dip Switch # 8.

If a dipswitch is set to ON, the corresponding bit is set to 1, otherwise if the dipswitch is set to OFF, the bit is set to 0. The most common configurations are listed in *Table 5*.

Dipswitch Value Display	
Machine Configuration	Value
120 Volt with Electric Pump	00
120 Volt with Gravity Drain	80
240 Volt with Electric Pump	01
240 Volt with Gravity Drain	81
240 Volt Heater Machine with Electric Pump and Cool Down Enabled	61
240 Volt Heater Machine with Gravity Drain and Cool Down Enabled	E1

Table 5

### Cycle Configuration Test

This step verifies which set of cycles are used.

Cycle Configuration Display		
Cycle Set	Models	Display
Default	With “T” and “C” in the 12 <sup>th</sup> character of the model number	“dE”
Australia	With “A” in the 12 <sup>th</sup> character of the model number	“AU”
International	All Other models	“in”

Table 6

### Cold/Detergent Fill

This step checks the cold water valve and the detergent/bleach valve. The cold water fill valve, the detergent/bleach valve and the External Supply Valve 1 turn on. The valves will shut off once a low fill level is reached.

### Hot/Softener Fill

This step checks the hot water valve and the softener valve. The hot water fill valve, the softener valve and the External Supply Valve 2 turn on. The valves will shut off once a medium fill level is reached.

### Pressure Sensor Fill

This step checks the analog water level input. When the water fill level is satisfied, the water valves are turned off. The control will not advance to the next step until the normal fill level is satisfied.



## WARNING

**To reduce the risk of electric shock, fire, explosion, serious injury or death:**

- **Disconnect electric power to the washer before servicing.**
- **Never start the washer with any guards/panels removed.**
- **Whenever ground wires are removed during servicing, these ground wires must be reconnected to ensure that the washer is properly grounded.**
- **Motor not grounded! Disconnect electric power before servicing motor.**

W485

### Heater (Heater Models Only)

This step checks the heater operation. The display shows “xx”, where xx is the temperature in degrees Celcius. The control will heat the water to 40 degrees Celcius while displaying the temperature as it rises at a rate of 1 degree. If the temperature sensor is open or shorted, the display will show “Er” and “OP” or “SH”.

### Overflow Test

This test checks the overflow setting for the water level sensor. When the overflow level is reached, the water valves, all External Supply Valves and the Cycle Run Output will automatically turn off. The control will not advance to the next step until the overflow level is satisfied.

### Low Agitate

This step checks the Low Agitate speed. The display shows “LA”, the Rinse LED is on, the Auxiliary Output 3 is on, Cycle Run Output is on, and the machine enters a low agitate. The control will remain in this mode until the Start/Pause keypad is pressed.

### Regular Agitate

This step checks the Regular Agitate speed. The display shows “rA”, the Rinse LED is on, the Auxiliary Output 4 is on, and the machine enters a regular agitate. The control will remain in this mode until the Start/Pause keypad is pressed.

### Pump/Gravity Drain Test

This step checks the Pump output. The display shows “Pu” for an electric pump or “dr” for a gravity drain, the Rinse LED is on, and the Pump is turned on or the Gravity Drain is opened. The control will only advance to the next test step after the Water Level Sensor indicates that the drum is empty.

### Factory Spin

This step checks the spin speeds. The display shows the most significant two digits of the actual RPM.

The machine steps through spin speeds and maintains each speed for a few seconds. After 1200 RPMs, the motor will stop. This step lasts 4 minutes. All Out of Balance checking is done and if either the out of balance switch is hit or the OBL check fails and needs to re-spin, the time will be reset indefinitely to allow the load to be rebalanced so that it can spin up and reach full speed. The control will advance to the next step if the Start/Pause keypad is pressed at any time during this step.

During this step if 800 RPMs is reached, LED number 27 will be lit. If 1000 RPMs is reached, the LED number 28 will be lit. If 1200 RPMs is reached, the LED number 29 will be lit, and if 1100 RPMs is reached, the LED number 30 will be lit to indicate that a passing speed has been reached. Refer to *Figure 1* for LED number definition.

### Breakaway

This step checks the breakaway speed and the door unlock function. All valves will be open at the beginning of this step to allow the blowing out of the valves by the factory. The Start/Pause keypad must be pressed to start exiting the test. The first Start/Pause keypress will turn off the water valves, the second Start/Pause keypress will stop the motor and start the unlock process. The third Start/Pause keypress will start the unlock process. Once the door unlocks, it needs to be opened to finally exit the test. The water level sensor will be trimmed in this step after a 20 second delay and once the Start/Pause key is pressed the first time.

During this step the LEDs for indicating speeds reached from the Factory Spin step will remain lit in this step.

### Power Down

This is the final step of factory test procedure. The control will display “Pd” to signify that the procedure has been completed and that the user can safely unplug the machine. Cycling power to the machine is the only way to resume normal operation.



## WARNING

To reduce the risk of electric shock, fire, explosion, serious injury or death:

- Disconnect electric power to the washer before servicing.
- Never start the washer with any guards/panels removed.
- Whenever ground wires are removed during servicing, these ground wires must be reconnected to ensure that the washer is properly grounded.
- Motor not grounded! Disconnect electric power before servicing motor.

W485

### 3. Motor Circuit

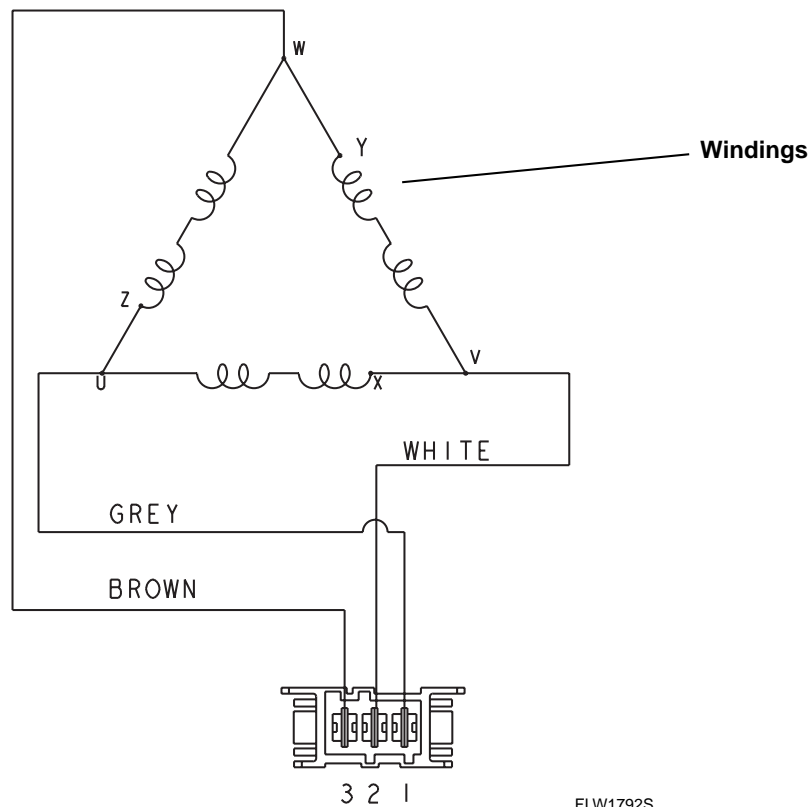

FLW1792S

#### Windings Resistance:

Approx. 3.38 ohms



## WARNING

To reduce the risk of electric shock, fire, explosion, serious injury or death:

- Disconnect electric power to the washer before servicing.
- Never start the washer with any guards/panels removed.
- Whenever ground wires are removed during servicing, these ground wires must be reconnected to ensure that the washer is properly grounded.
- Motor not grounded! Disconnect electric power before servicing motor.

W485

### 4. Dipswitch Configuration

	OFF	ON
Switch 1	120 Volt AC Supply	240 Volt AC Supply
Switch 2*	Energy Saving Cycles	Standard Cycles
Switch 3**	Default Water Level	Increased Water Level
Switch 4	Leak and Slow Drain Errors Off	Leak and Slow Drain Errors On
Switch 5	Unused	Unused
Switch 6	Cool Down Disabled	Cool Down Enabled
Switch 7	Heater Disabled	Heater Enabled
Switch 8	Electric Pump	Gravity Drain

Table 7

#### \*Switch 2

When set to OFF, energy saving water and fill levels are used for the specific type/region of the machine. When set to ON, energy saving cycle settings are not used.

#### \*\*Switch 3

When set to OFF, the Default Water Levels are used. When set to ON, the owner can increase the water level using the Extra Water Mode. Higher water levels are not recommended as they may result in water leaking from the machine door.



## WARNING

To reduce the risk of electric shock, fire, explosion, serious injury or death:

- Disconnect electric power to the washer before servicing.
- Never start the washer with any guards/panels removed.
- Whenever ground wires are removed during servicing, these ground wires must be reconnected to ensure that the washer is properly grounded.
- Motor not grounded! Disconnect electric power before servicing motor.

W485

### 5. Troubleshooting Knocking Noise

If a frontload washer produces a noise similar to a knock on a door, it might be due to a flat spot on the belt. The knocking sound is made when the flat spot hits the pulley. The knocking may occur during a ramp spin and fade after reaching a higher RPM.

To correct this condition, replace the belt.

### 6. Explanation of LEDs on Drive Control

There are four LEDs on the control to assist with troubleshooting (refer to *Figure 2*):

1. Green LED on constant = 5VDC power supply present
2. Green LED flashing one second on/one second off = drive control is active
3. Red LED flashing = drive control is communicating with front end control
4. Red LED on constant = DC Bus Charged

**NOTE: Drive is only powered when door is closed and front end control turns it on.**

### 7. Door Fails to Unlock at End of Cycle

If the door won't unlock at the end of the cycle and the cycle time is flashing in the display, the water might be too hot to drain. Add a cool-down step to the cycle to make sure the water will be cooled. Enable the cool-down feature by setting the cool down dip switch (#6) to ON.

### 8. No Spin

A no spin condition is not caused by intermittent operation of the motor or motor control (inverter assembly). **DO NOT** replace these components for no spin complaints if the unit passes the following procedure:

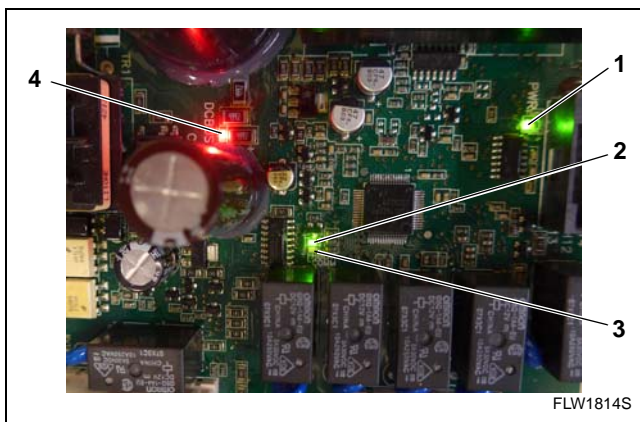

Figure 2



# WARNING

To reduce the risk of electric shock, fire, explosion, serious injury or death:

- Disconnect electric power to the washer before servicing.
- Never start the washer with any guards/panels removed.
- Whenever ground wires are removed during servicing, these ground wires must be reconnected to ensure that the washer is properly grounded.
- Motor not grounded! Disconnect electric power before servicing motor.

W485

## 8. No Spin (continued)

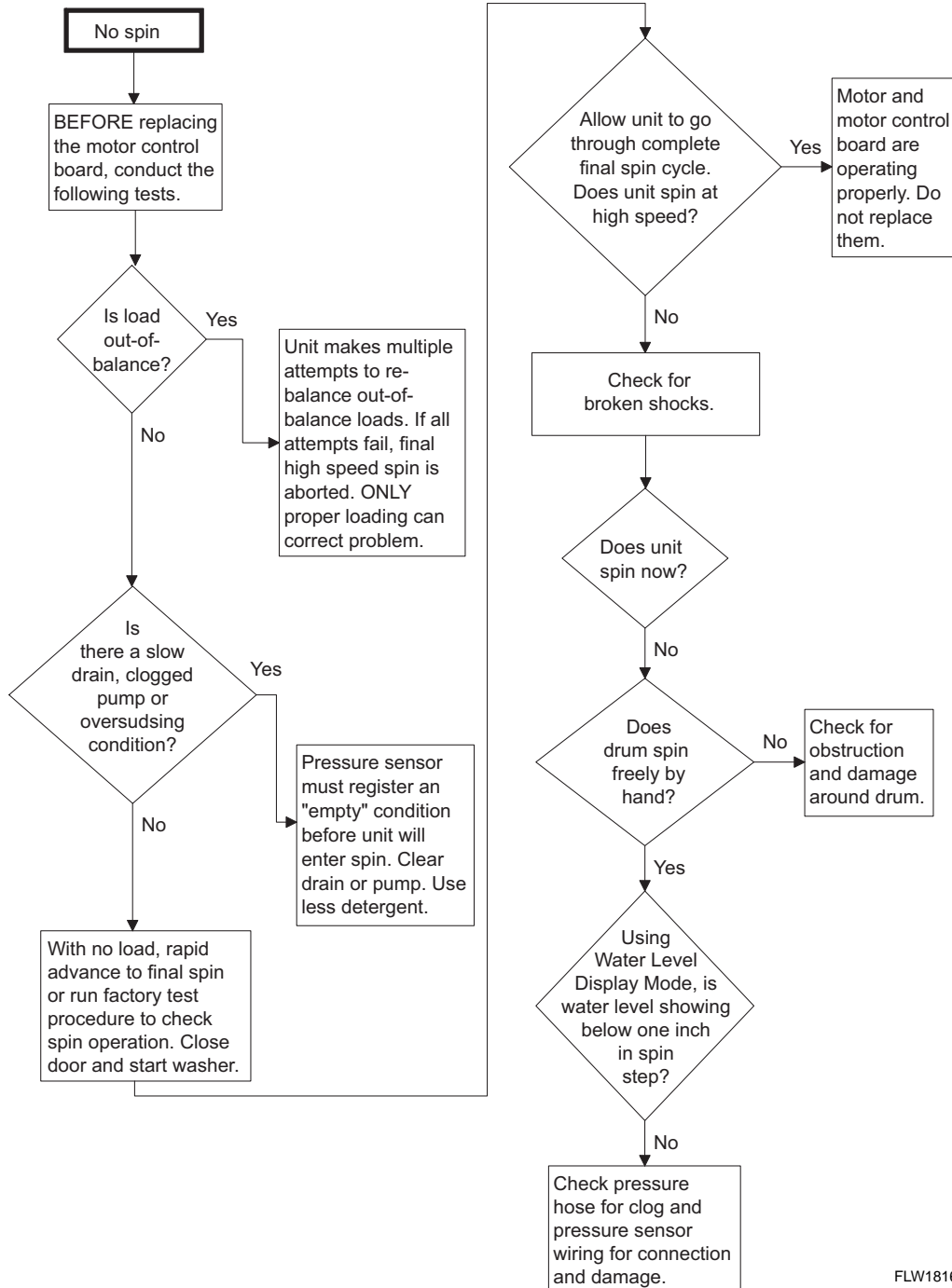

FLW1816S





## WARNING

To reduce the risk of electric shock, fire, explosion, serious injury or death:

- Disconnect electric power to the washer before servicing.
- Never start the washer with any guards/panels removed.
- Whenever ground wires are removed during servicing, these ground wires must be reconnected to ensure that the washer is properly grounded.
- Motor not grounded! Disconnect electric power before servicing motor.

W485

## 9. Excessive Vibration and/or Noise During Spin

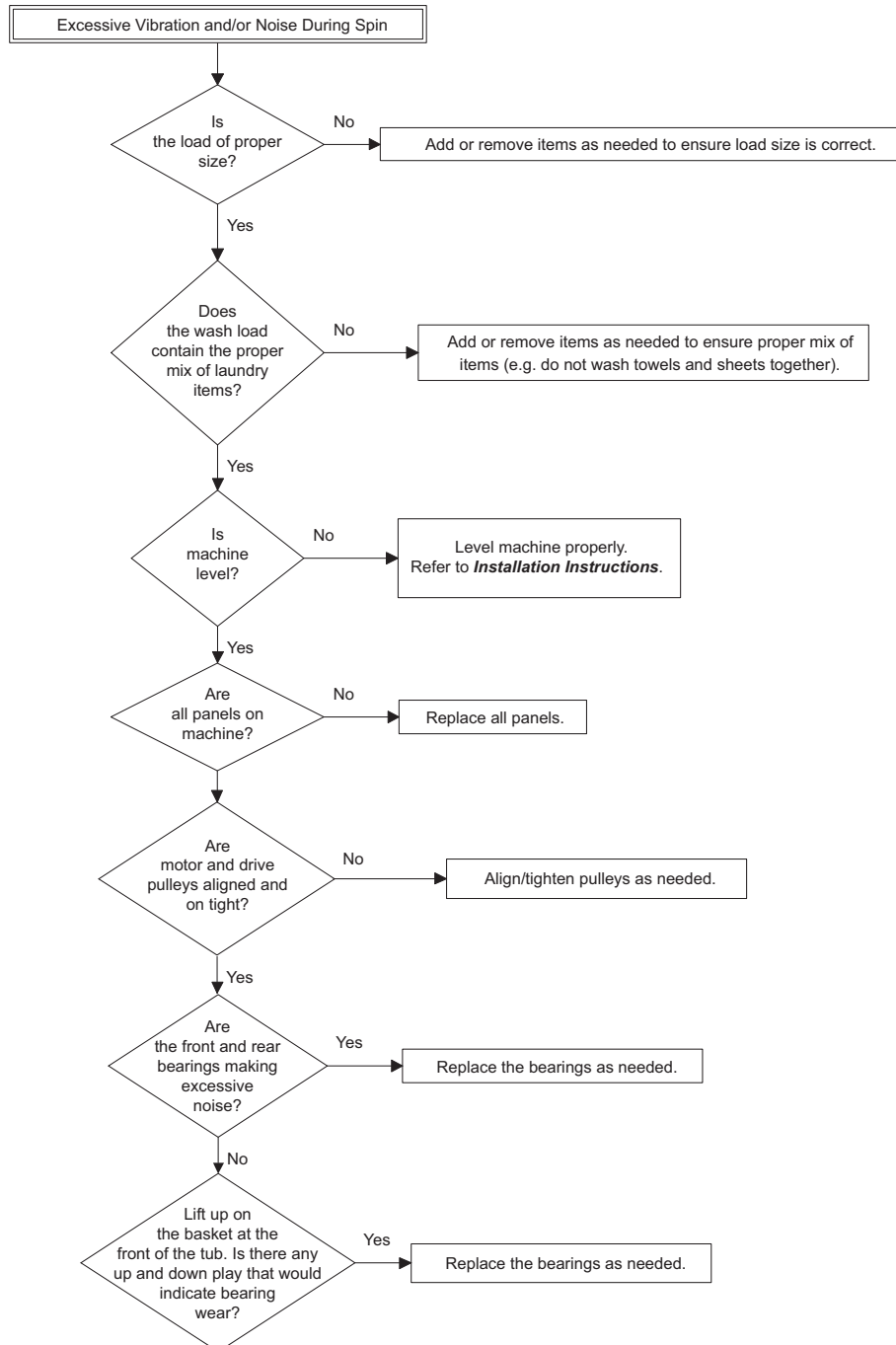

FLW1809S



# WARNING

To reduce the risk of electric shock, fire, explosion, serious injury or death:

- Disconnect electric power to the washer before servicing.
- Never start the washer with any guards/panels removed.
- Whenever ground wires are removed during servicing, these ground wires must be reconnected to ensure that the washer is properly grounded.
- Motor not grounded! Disconnect electric power before servicing motor.

W485

## 10. Excessive Cycle Time

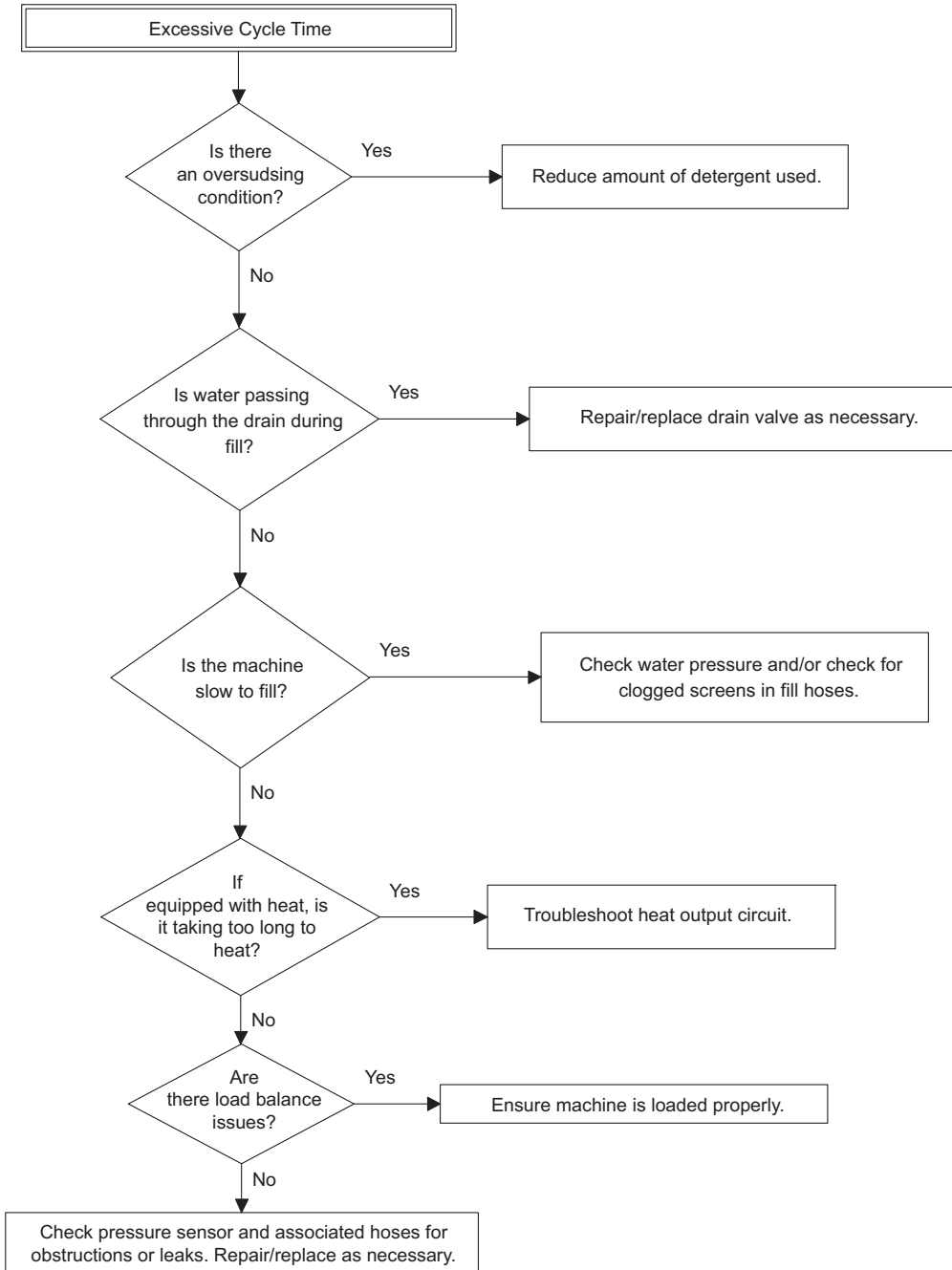

FLW1819S

# Section 4

## Electronic Control Troubleshooting

	WARNING
<p>To reduce the risk of electric shock, fire, explosion, serious injury or death:</p> <ul style="list-style-type: none"> <li>• Disconnect electric power to the washer before servicing.</li> <li>• Never start the washer with any guards/panels removed.</li> <li>• Whenever ground wires are removed during servicing, these ground wires must be reconnected to ensure that the washer is properly grounded.</li> <li>• Motor not grounded! Disconnect electric power before servicing motor.</li> </ul>	
W485	

### 11. Error Codes

Following is a list of possible error codes for an electronic control.

**NOTE: Error codes will be displayed with multiple codes. For example, the display will switch between “Er” and “dL” for a door open error.**

Display	Description	Cause/Corrective Action
Left most decimal point Lit	Control is in Bootloader Mode.	Control is waiting for firmware update. (Firmware updates only done by Alliance Laundry Systems Service Technicians.) If firmware is not being updated, cycle power to machine. If error still occurs, replace control.
Right most decimal point blinking	Control is in Low Power/Idle Mode.	While control is in Low Power/Idle Mode, right most decimal on display will blink once per minute on controls with software version 6 or lower and once every five minutes on controls with software version 7 or higher. This is normal. Press the Power/Cancel keypad to turn control back on.
<i>Er, FL</i>	Fill Error	Fill level is not reached within 30 minutes in any fill step. Check for water pressure at inlets, water valves for operation, clog in water line, plugged filter screen on water hose, and the pressure sensor hose for air leak to determine cause of error. Power down to clear error.
<i>Er, dL</i>	Door Lock Fatal Error	Door is unlocked during a running cycle. To clear this error, cycle power to the machine. Check door lock and door latch for damage and replace if error continues. Also check door lock wire harness for damage or for disconnection.
<i>Er, dI</i>	Door Lock Non-Fatal Error	If the door fails to lock in 20 seconds in Door Locking Mode after the drive has been enabled, the control will turn off all outputs and display error code. To clear this error the door must either open or lock. Overloading the machine or broken shocks may keep door from properly closing. First check that door is fully closed. If door still fails to lock, check door lock and latch for damage. Check door lock wire harness for damage or disconnection.

Table 8 (continued)

Table 8 (continued)

Display	Description	Cause/Corrective Action
<i>Er, dU</i>	Door Unlock Non-Fatal Error	If the door fails to unlock 20 seconds after the drum has stopped spinning with a solenoid type door lock and all other outputs have been turned off, the control will display error code. To clear this error the door must unlock or open. Removing power for 3 minutes will automatically allow door lock to unlock. Make sure to press on door and then pull to unlock the door as pressure on door lock/latch will prevent door from unlocking. Possible causes of this issue are broken shocks or clothes load causing pressure on door and door latch/lock preventing it from unlocking. If it still fails to unlock, check door lock and latch for damage. Also check door lock wire harness for damage or disconnection.
<i>Er, do</i>	Door Opened Error	Control detects door open during a cycle. This can be caused by pulling on door while locked or about to lock. Correct inoperative door locking system. Check door switch and harness for damage or disconnection. Unpower machine to clear error.
<i>Er, ub</i>	Non-Fatal Unbalance Error	Washer is unable to balance load. Redistribute load and run cycle. If running a small load or one large item, add more items to help machine balance the load better. If items are rubber or other water resistant type material, load may never reach full spin speed. Ensure machine is properly leveled and check for broken shocks. Open door or press Power/Cancel keypad to clear error.
<i>Er, Ub</i>	Fatal Unbalance Error	Wires to unbalance switch are broken or not connected, unbalance switch may be stuck closed or a shock may be broken. Unpower to clear error.
<i>do</i>	Door Open Indicator	Door needs to be closed to start cycle. If door is closed, check for improper wiring or faulty door switch.
<i>Er, dS</i>	Brownout/Voltage Configuration	Unexpected supply voltage. Check the harness connections between the front end control and the drive board. If the front end control was replaced, set dip switch #1 to the same setting as the previous control. If reworking the machine to use a different voltage supply, the dip switch #1 setting may need to be changed. If the dip switch #1 setting is changed, power down, power up and try again. Also check Pin H2-7 on the front end control to ensure good connection between front end control and drive board.
<i>Er, nr</i>	Drive Board Not Ready	Hardware failure. Try cycling power to machine before replacing drive board.
<i>Er, bS</i>	Drive Board Shorted	Hardware failure. Try cycling power to machine before replacing drive board.

Table 8 (continued)

Table 8 (continued)

Display	Description	Cause/Corrective Action
$E_r, Co$	Drive Board Communication Error	Communication failure. Power down, power up and try again. If error persists, check connection between front end control and drive board, or try replacing the front end control or the drive board. Many times a loose pin or wire is at fault for this error.
$E_r, dr$	Drain Error	The control will enter Machine Error Mode when the water height is not below the empty level, after attempting to drain for 2 minutes. In the event of a drain error, the control will turn off all outputs and turn on the Machine Error Tone for 15 seconds. Check wiring to drain and that power is present at drain. Check for objects stuck in drain hose or in pump on electric pump units. Ensure that drain hose meets drain height restrictions. Unpower to clear error.
$E_r, Sd$	Slow Drain Error	This error occurs only if enabled by setting dip switch #4 to ON. Water is not draining as quickly as expected in any cycle step that drains water during the cycle. Clear this error by pressing the Power/Cancel keypad.
$E_r, Ht$	Heater Error (machines equipped with heater)	If the heater is enabled and the water temperature has not reached the desired temperature selection within 2 hours, the control will indicate a heater error. If this error occurs, the heater output will be turned off and the cycle will continue. This error will be cleared when the door is opened or the Power/Cancel keypad is pressed. Possible causes include wire harness to heater elements are damaged, heater elements are damaged, corrosion of wires/connectors.
$E_r, tE$	Max Temperature Exceeded Error (machines equipped with heater)	The control will continuously monitor the Machine Status for an indication that the maximum water temperature is exceeded. When the cycle has been completed and if the control has saved a Max Temperature Exceeded Error, the control shows the error for one minute after the door is opened or the Power/Cancel keypad is pressed. Check for stuck heater relay/contactors.
$E_r, oP$	Open Temperature/Thermistor Sensor Error (machines equipped with heater)	The drive board will flag an Open Thermistor Error any time it senses a temperature less than 0°C (32°F). The heater output is turned off for the remainder of the cycle. At the end of the cycle, error code will be shown. It clears after one minute or with the Power/Cancel keypad press. Check wiring to heater elements and thermistor for damage.

Table 8 (continued)

Table 8 (continued)

Display	Description	Cause/Corrective Action
<i>Er, 5H</i>	Shorted Temperature/Thermistor Sensor Error (machines equipped with heater)	The drive board will flag a Shorted Thermistor any time it senses a temperature greater than 100°C (212°F). The heater output is turned off for the remainder of the cycle. At the end of the cycle, error code will be shown. It clears after one minute or with the Power/Cancel keypad press. Check wiring to heat elements and thermistor for damage.
<i>Er, 5L</i>	Suds Lock Error	In the spin steps, if the control determines that there are suds in the machine after running all Suds Removal Routines programmed to run, it will display a Suds Lock Error at the end of the cycle after the door is opened. The control will continue showing the error for one minute or until the Power/Cancel keypad has been pressed. To prevent error, reduce detergent used. Check for draining issues, check that drum spins freely, and make sure no small items are lodged between drum and outer tub.
<i>Er, Hd</i>	Too Hot To Drain Error	If water is detected to be too hot to drain safely, this error will occur. It is advised to add the Cool Down feature by setting #6 dip switch to ON to avoid this error. Another possible cause of this error is that the heater contactor/relay is stuck on. Error will display after door is opened in End of Cycle Mode. It will clear after 1 minute or the Power/Cancel keypad is pressed.
<i>Er, LE</i>	Water Leak Drain Error	This error occurs only if enabled by setting dip switch #4 to ON. If there is a leak during the water leak detection of the cycle an error will display after the door is opened at the end of cycle for 1 minute. It will clear after 1 minute or until the Power/Cancel keypad is pressed. If the water level has dropped more than an acceptable amount during a water leak drain check, the control will save a water leak drain error status and will continue the machine cycle. The cause of this error may be the drain hose, pump, or fill valve leaking or a stuck gravity drain valve on gravity drain machines.
<i>Er, nF</i>	No Water Flow Error	If the control does not reach a water level of 4 inches within the first 5 minutes of starting the fill it may mean the hose to the pressure sensor has a leak, is disconnected or clogged, the water inlet hose is clogged, the water inlet screens are clogged, or no water is flowing into the machine. The control will enter Machine Error mode when the error is set. The control will first drain for 90 seconds and then turn off all outputs and turn on the Machine Error Tone for 15 seconds. Unpower to clear error.

Table 8 (continued)

Table 8 (continued)

Display	Description	Cause/Corrective Action
<i>Er, OF</i>	Overflow Error	This error is triggered when an unsafe high water level is detected in the machine and water is unable to drain. The water valve may be stuck open, pump may be stuck, or the drain may be clogged. Typically a small item is lodged in the propeller of the pump on pump machines. The door may be open/unlocked with water sitting in the machine to cause this error. Unpower to clear error.
<i>Er, PS</i>	Pressure Sensor Error	If the control does not detect a valid water level sensor input for 30 seconds, or if the Max (Overflow) Fill Level in the control is set to 0 while in Run Mode, Factory Test Mode, or Overflow Mode, the control will enter Machine Error Mode. Check harness from user control to pressure sensor for damage and replace if necessary. Replace pressure sensor or user control if error persists. The control will first drain for 30 seconds to get out any water and then unlock the door. Unpower to clear error.
<i>Er, bb</i>	Broken Belt Error	If a broken belt is detected by the control, the control will display this error. Unpower the machine and check the belt and pulleys for issues.
<i>Er, LF</i>	Water Leak Fill Error	If there is a leak during the water leak detection of the cycle when programmed on, an error will display after the door is opened at the end of cycle for 1 minute. It will clear after 1 minute or when a keypad is pressed. If the water level has increased more than an acceptable amount during a water leak drain check, the control will save a water leak drain error status and will continue the machine cycle. Immediately upon detecting the error the rightmost decimal point will be lit. This lit decimal point can be cleared by pressing the START keypad 3 times in a period of 5 seconds or by cycling the power to the machine. There may be a water valve stuck open due to debris or a failed water valve.
Display is dim		Look for loose pins and damaged wires on harness from user control to drive board.
<i>Er, id</i>	Drive Board ID Error	This error will be displayed if after checking for drive board/front end control compatibility it is found not to match. Unpower machine to clear code. Change front end control to one for a frontload washer.
<i>PF</i>	Power Fail Error	If control was in Delayed Start mode during a power failure, this error will be displayed and the delayed start will be canceled. Press Power/Cancel to clear the error.

Table 8 (continued)

Table 8 (continued)

Display	Description	Cause/Corrective Action
<i>E<sub>d</sub></i>	Drive Board Errors	
<i>E<sub>d</sub>, 10</i>	Voltage Select Error	Wrong Input Voltage seen at drive board 120V vs 240V. Dip switch 1 on FEC set wrong, or possibly water on drive board (let drive dry out and determine cause of water). Unpower to clear error. Replace drive board if error persists.
<i>E<sub>d</sub>, 12</i>	Over Voltage AC-Main Input Error	Machine voltage is too high, check supply voltage to the machine and verify that it is within machine specifications. Unpower to clear error. Replace drive board if error persists.
<i>E<sub>d</sub>, 13</i>	Power Fail Dangerous Error	The Neutral Line power input to the machine was seen out of range. Unpower to clear error. Check for damage in the power supply harness. Replace power supply harness or drive board if error persists.
<i>E<sub>d</sub>, 21</i>	Over Voltage DC Bus Error	Unpower to clear error. Check voltage input to machine. If it happens only at start of spin, replace motor. Replace drive board if error persists.
<i>E<sub>d</sub>, 22</i>	Over Motor Temperature Error	Motor temperature is detected to be too high. Check that drum spins freely when empty. Check for overloading of machine. Check motor harness for damage. Reduce agitation time and duty cycle if rotate/pause times are very short and programmable. Unpower to clear error. Replace drive board if error persists.
<i>E<sub>d</sub>, 23</i>	Fatal IPM Over Current Shunt Error	Check that drum and motor spins freely. Unpower to clear error. Check the motor phase windings. Continuity should be uniform between phases L1 and L2, L2 and L3, L1 and L3. Replace motor if not uniform. Replace drive board if error persists.
<i>E<sub>d</sub>, 24</i>	Fatal I2T Hardware Over Current Error	Check that drum and motor spins freely. Rotor may be locked up. Check the motor phase windings. Continuity should be uniform between phases L1 and L2, L2 and L3, L1 and L3. Replace motor if not uniform. Unpower to clear error. Replace drive board if error persists.
<i>E<sub>d</sub>, 25</i>	IPM Over Temperature Error	IPM temperature is detected to be too high. Check that drum spins freely when empty, check for overloading of machine, reduce agitation time, and duty cycle if rotate/pause times are very short and programmable. Unpower to clear error. Check for lint build-up on heat sink on drive board. Replace drive board if error persists.

Table 8 (continued)

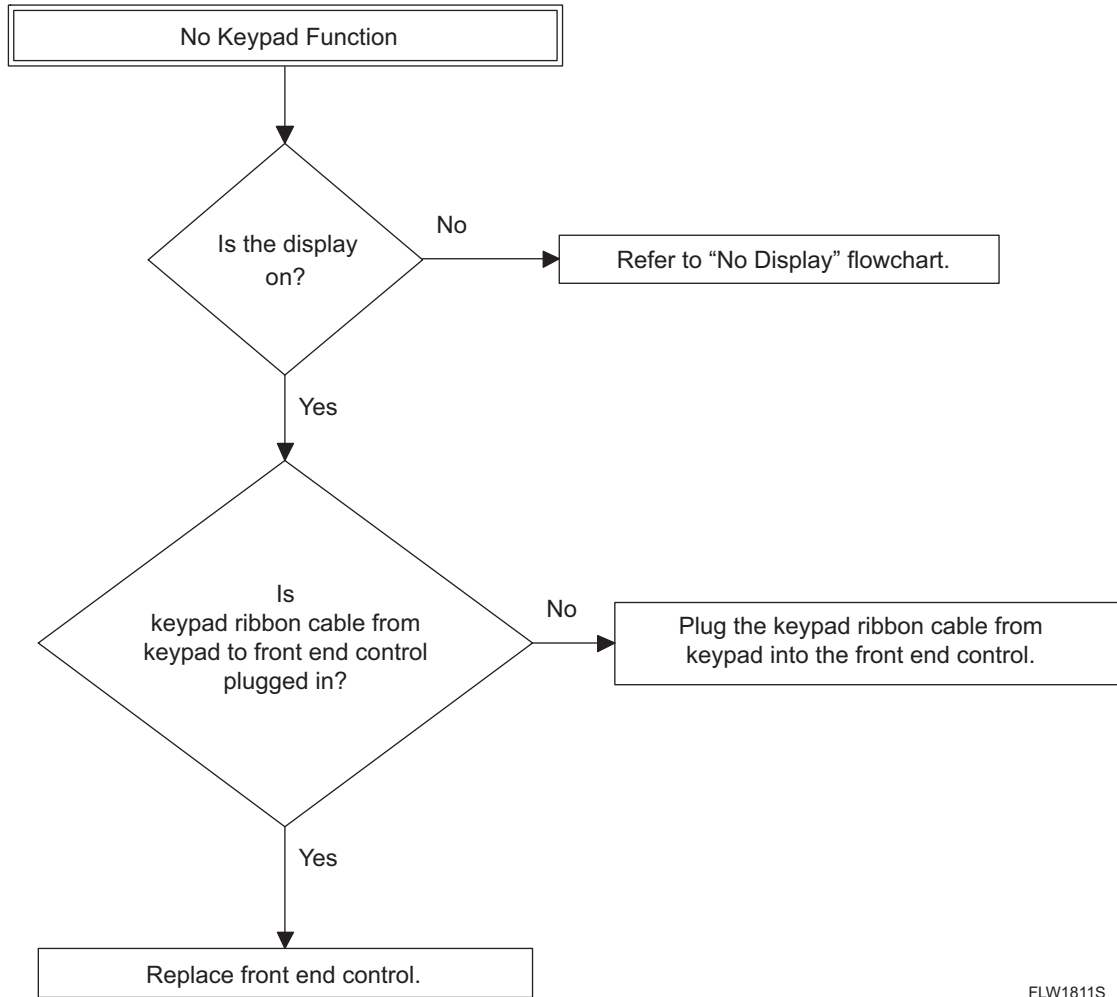

Table 8 (continued)

Display	Description	Cause/Corrective Action
<i>Ed, 29</i>	Motor Not Connected Error	The motor or one of its electrical phases is not connected. Check that the harness from the motor to the drive board is fully plugged in on both ends and that there is no damage to the motor harness. Make sure to push in the motor harness on both ends just in case it is a little loose and not fully inserted. If the harness looks fine and the error still occurs, try replacing the drive board or harness. Unpower to clear error.
<i>Ed, 44</i>	Overcurrent Shunt Detection Circuit Fail Error	Hardware failure. Unpower to clear error. Replace drive board if error persists.
<i>Ed, 45</i>	Door Lock Pin HW On/Off Fail Error	Hardware failure. Unpower to clear error. Replace drive board if error persists.
<i>Ed, 46</i>	Heater Pin HW On/Off Fail	Hardware failure. Unpower to clear error. Replace drive board if error persists.
<i>Ed, 47</i>	Hot Valve Pin HW On/Off Fail	Hardware failure. Unpower to clear error. Replace drive board if error persists.
<i>Ed, 48</i>	Cold Valve Pin HW On/Off Fail	Hardware failure. Unpower to clear error. Replace drive board if error persists.
<i>Ed, 49</i>	Detergent Valve Pin HW On/Off Fail	Hardware failure. Unpower to clear error. Replace drive board if error persists.
<i>Ed, 50</i>	Softener Valve Pin HW On/Off Fail	Hardware failure. Unpower to clear error. Replace drive board if error persists.
<i>Ed, 51</i>	Inrush Pin HW On/Off Fail	Hardware failure. Unpower to clear error. Replace drive board if error persists.
<i>Ed, 52</i>	Voltage Doubler Pin HW On/Off Fail	Hardware failure. Unpower to clear error. Replace drive board if error persists.
<i>Ed, 53</i>	Door Lock Select Voltage Pin HW On/Off Fail	Hardware failure. Unpower to clear error. Replace drive board if error persists.
<i>Ed, 54</i>	Pump Pin HW On/Off Fail	Hardware failure. Unpower to clear error. Replace drive board if error persists.
<i>Ed, 55</i>	Fatal NTC Short Error	Check heater thermistor and thermistor wiring for damage. Unpower to clear error. Replace drive board if error persists.
<i>Ed, 56</i>	Fatal NTC Open Error	Check heater thermistor and thermistor wiring for damage. Unpower to clear error. Replace drive board if error persists.
<i>Ed, 63</i>	Fatal IPM Temperature Short Error	Hardware failure. Unpower to clear error. Replace drive board if error persists.
<i>Ed, 64</i>	Fatal IPM Temperature Open Error	Hardware failure. Unpower to clear error. Replace drive board if error persists.

Table 8

## 12. No keypad Function



FLW1811S

### 13. No Visible Display on Control

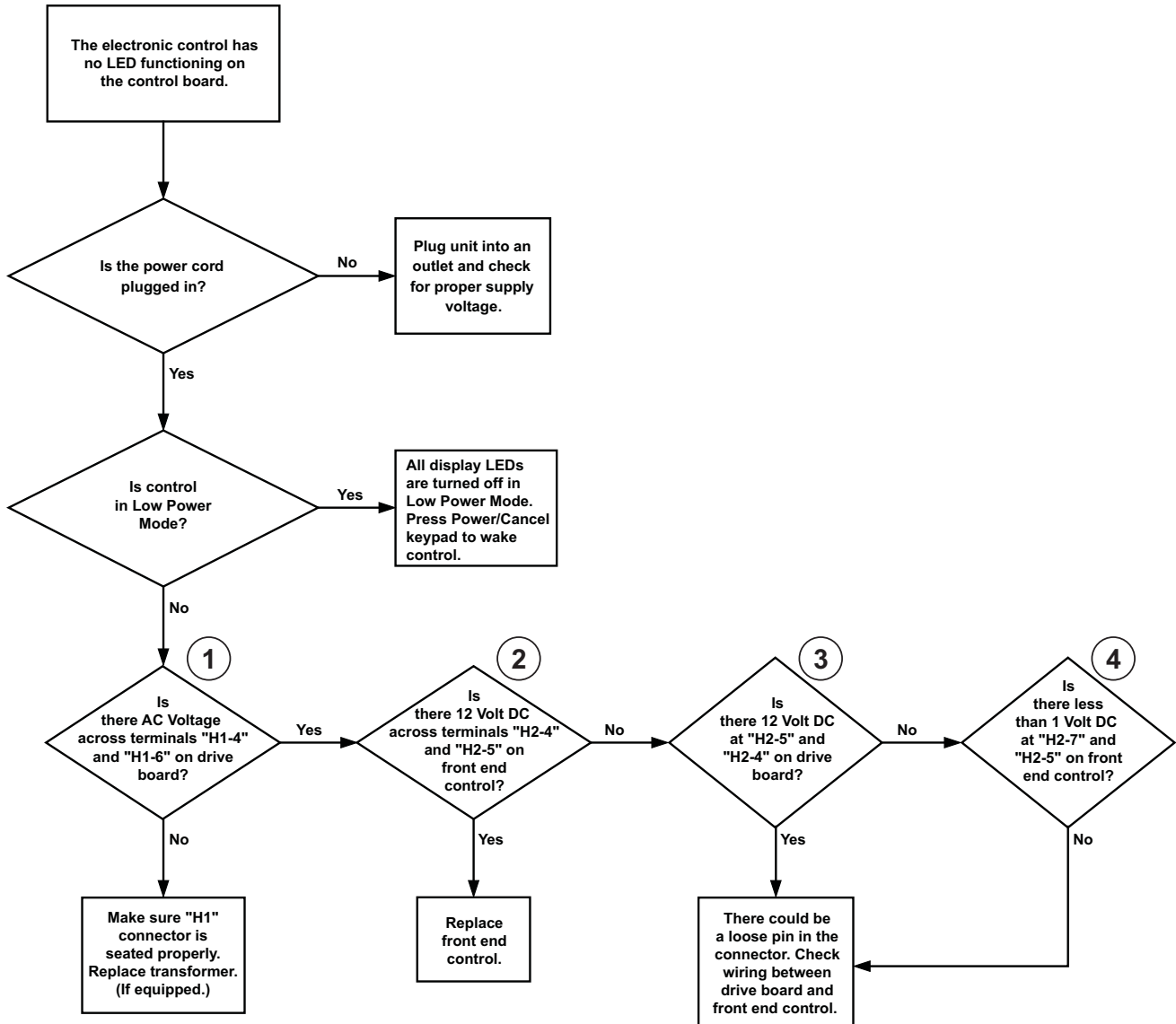

FLW1820S

No Visible Display on Control

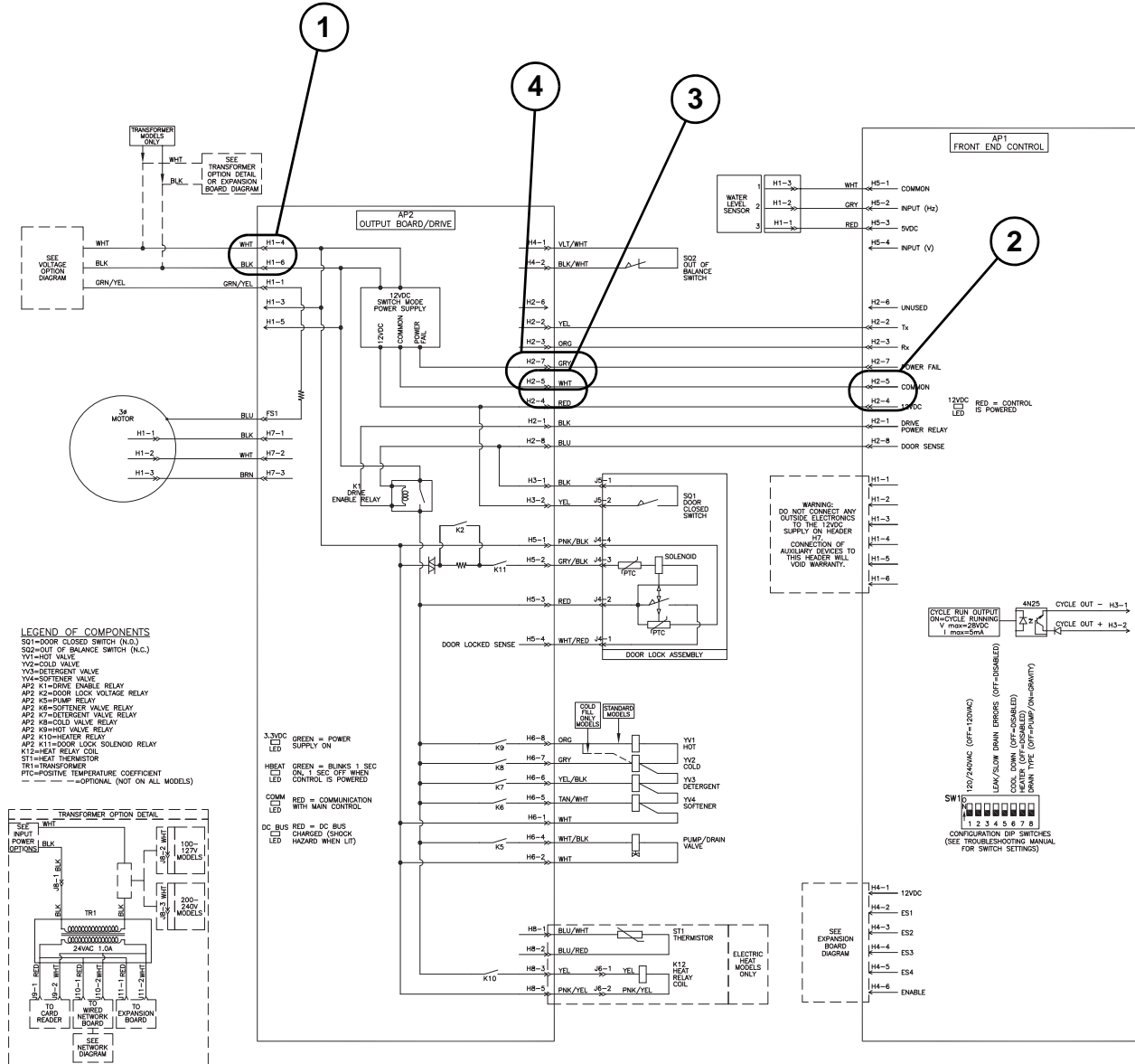

### 14. Washer Will Not Start – “do” Displayed

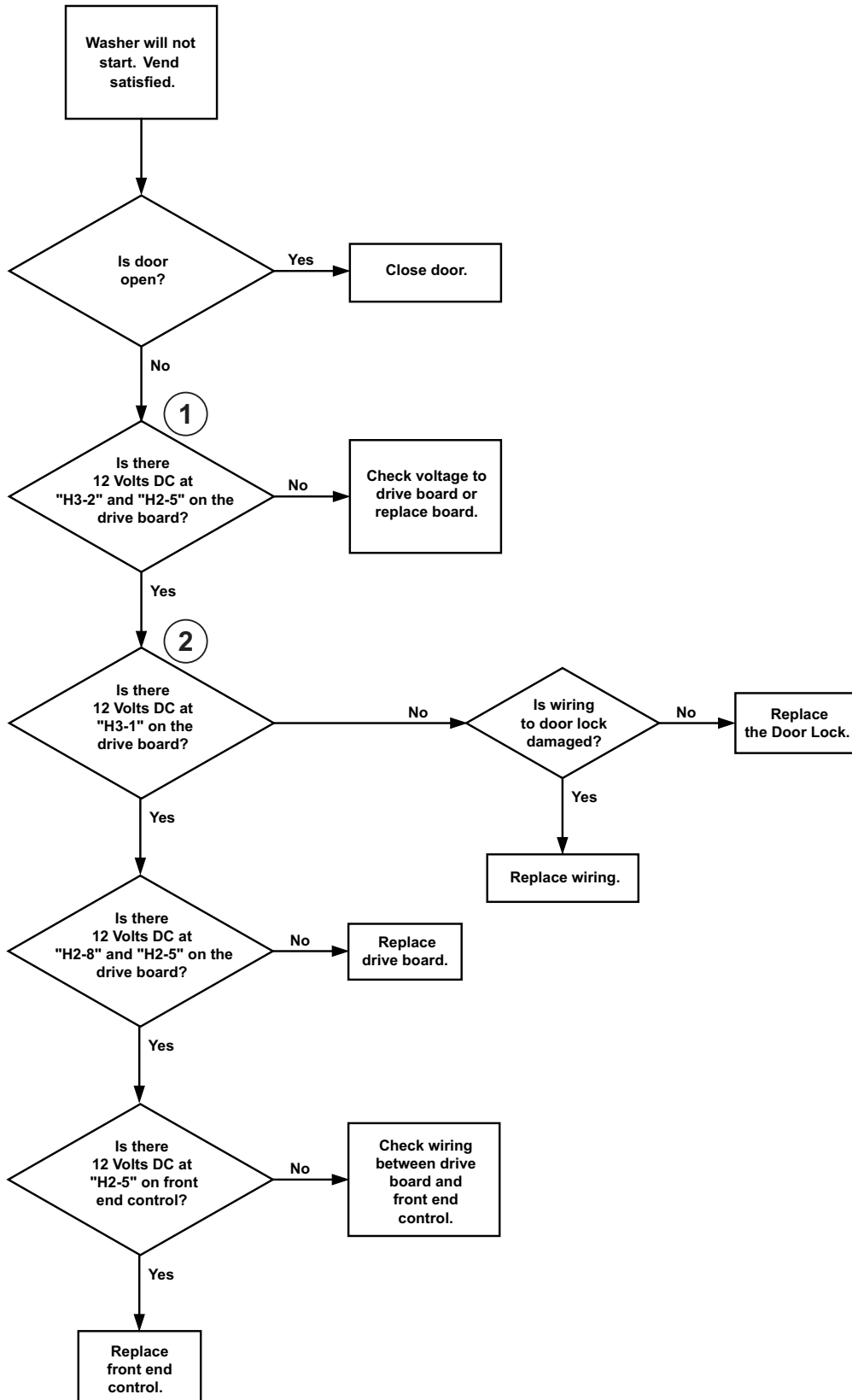

FLW1821S

# Washer Will Not Start – “do” Displayed

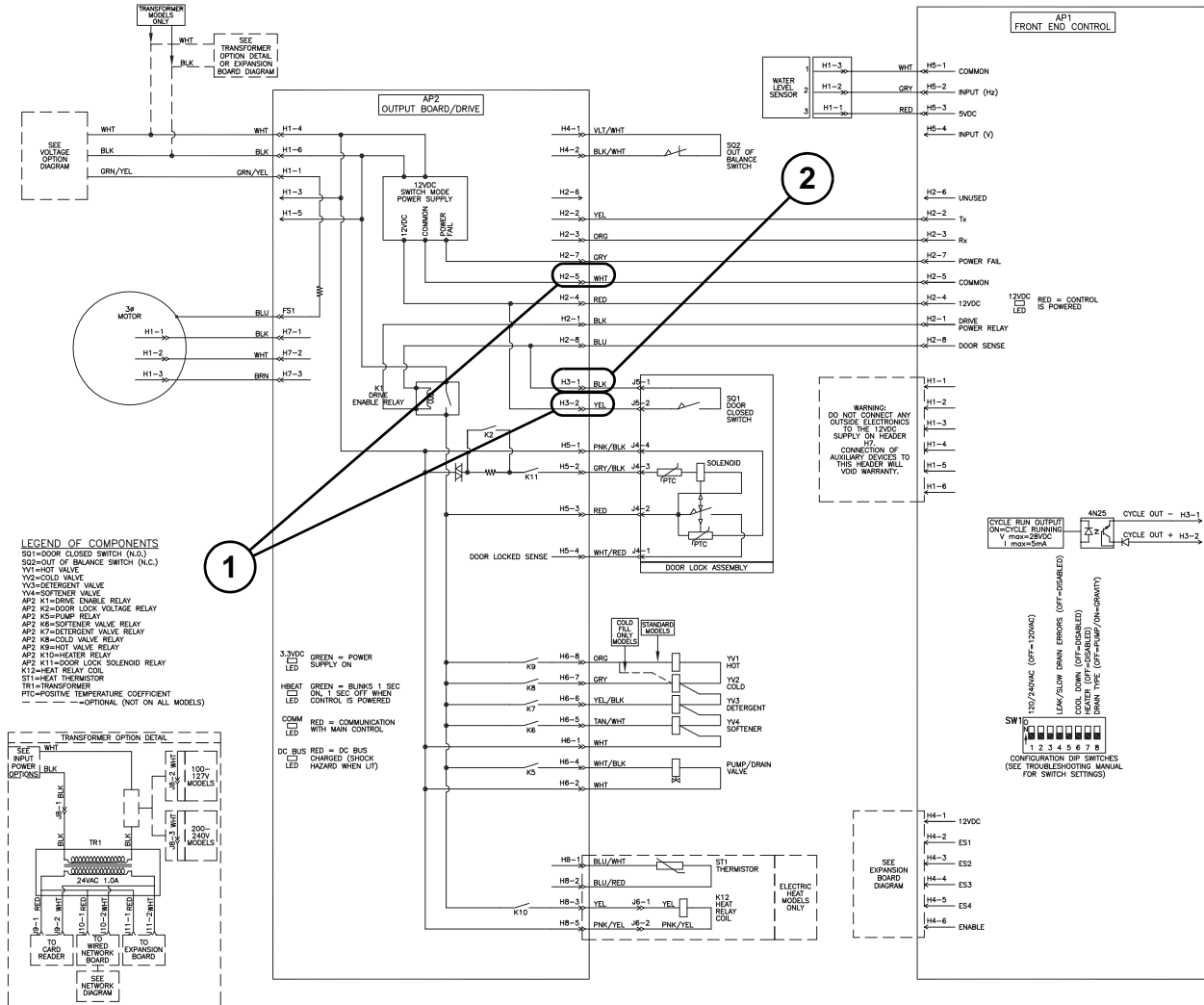

<p><b>WARNING</b></p> <p>Some internal parts are not grounded and may present a risk of electric shock when servicing. SERVICE PERSONNEL: DO NOT contact the motor, motor control, or drain valve when the machine is plugged in.</p>	<p><b>WARNING</b></p> <p>Failure to install, maintain, and/or operate this machine according to manufacturer's instructions may result in conditions which can produce body injury and/or property damage.</p>	<p><b>NOTE</b></p> <p>POWER SUPPLY WIRING MUST HAVE CORRECT POLARITY AND GROUNDING FOR THE UNIT TO OPERATE CORRECTLY.</p>	<p><b>ATTENTION</b></p> <p>Seules pièces internes ne sont pas fondées et peuvent présenter un risque de choc électrique lors de l'entretien. Personnel de service, de ne pas contacter le moteur, le contrôle moteur, ou le robinet et viderg lorsque l'appareil est branché.</p>	<p><b>AVERTISSEMENT</b></p> <p>Si vous n'installez pas et/ou n'effectuez pas les opérations d'entretien et/ou ne faites pas fonctionner cette machine conformément aux instructions du fabricant, vous favorisez les situations dangereuses tant au niveau de blessures corporelles que celle de dommages à la propriété qui pourraient en résulter.</p>	<p><b>REMARQUE</b></p> <p>Le câblage d'alimentation électrique doit être correctement polarisé et mis à la terre pour que l'appareil fonctionne correctement.</p>
---	--	---	---	--	---

### 15. Washer Will Not Start – “Er”, “dl” on Display

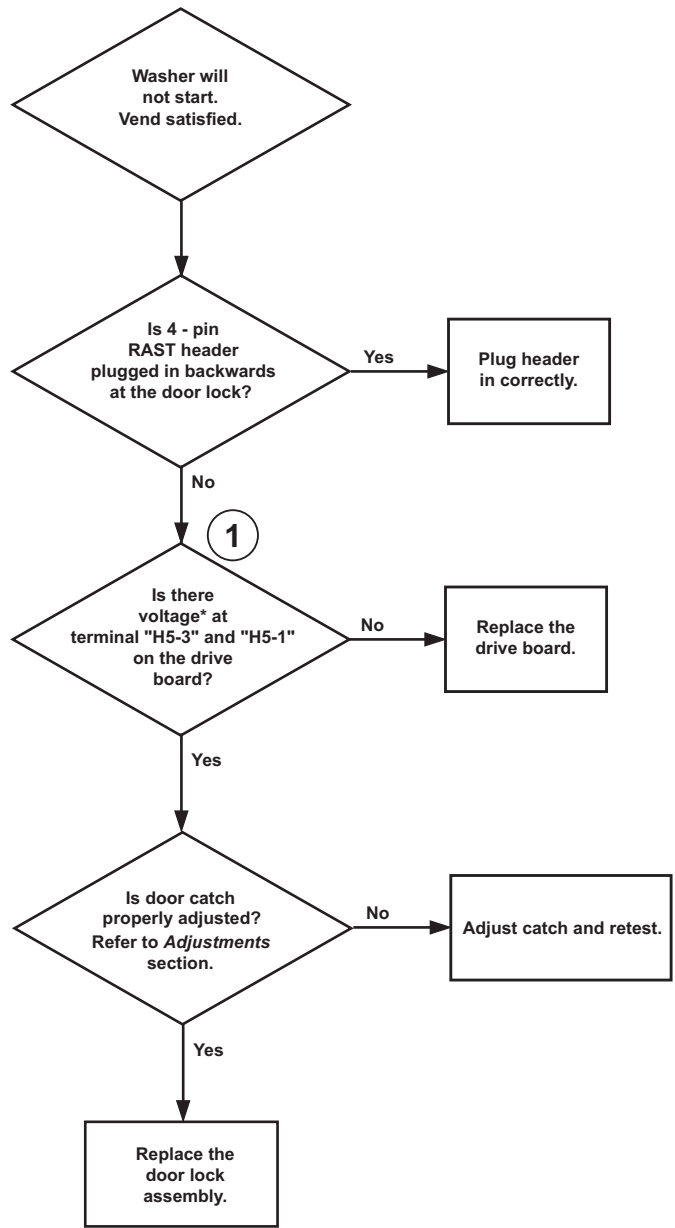

\*Refer to machine serial plate for correct voltage.

FLW1800S

# Washer Will Not Start – “Er”, “dl” on Display

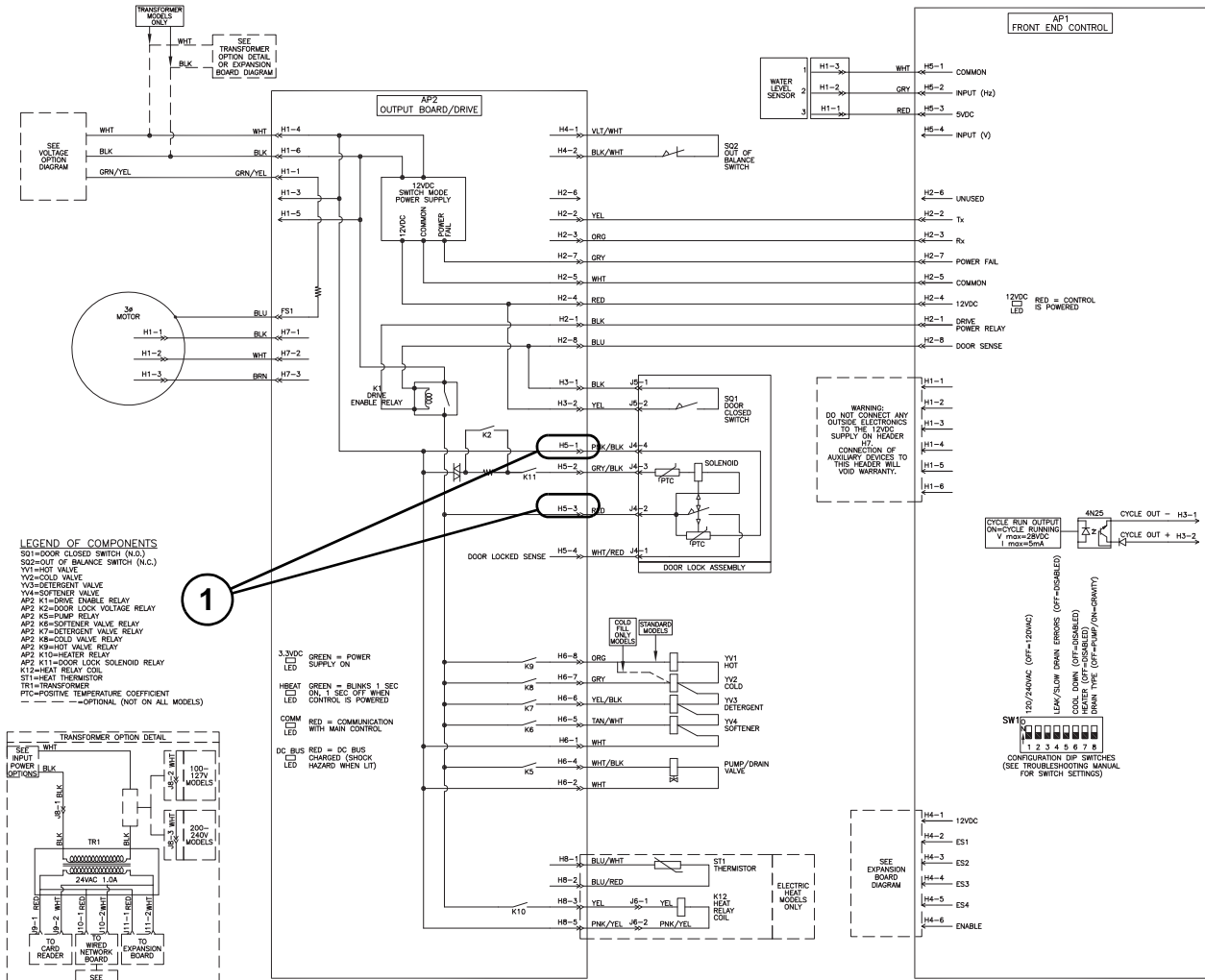

<p><b>WARNING</b></p> <p>Some internal parts are not grounded and may present a risk of electrical shock when servicing. SERVICE PERSONNEL DO NOT contact the motor, motor control, or drain valve when the machine is plugged in.</p>	<p><b>WARNING</b></p> <p>Failure to install, maintain, and/or operate this machine according to manufacturer's instructions may result in conditions which can produce bodily injury and/or property damage.</p>	<p><b>NOTE</b></p> <p>POWER SUPPLY WIRING MUST HAVE CORRECT POLARITY AND GROUNDING FOR THE UNIT TO OPERATE CORRECTLY.</p>	<p><b>ATTENTION</b></p> <p>Certains pièces internes ne sont pas fondées et peuvent présenter un risque de choc électrique lors de l'entretien. Personnel de service, de ne pas contacter le moteur, le contrôle moteur, ou le robinet de vidange lorsque l'appareil est branché.</p>	<p><b>AVERTISSEMENT</b></p> <p>Si vous n'installez pas et/ou n'entretenez pas les opérations conformément aux instructions du fabricant, vous favorisez les situations dangereuses tant au niveau de blessures corporelles que celle de dommages à la propriété qui pourraient en résulter.</p>	<p><b>REMARQUE</b></p> <p>Le câblage d'alimentation électrique doit être correctement polarisé et mis à la terre pour que l'appareil fonctionne correctement.</p>
--	--	---	--	---	---

FLW1817S



## 16. Washer Will Not Fill (Machine Empty, No “Er”, “PS” on Display)

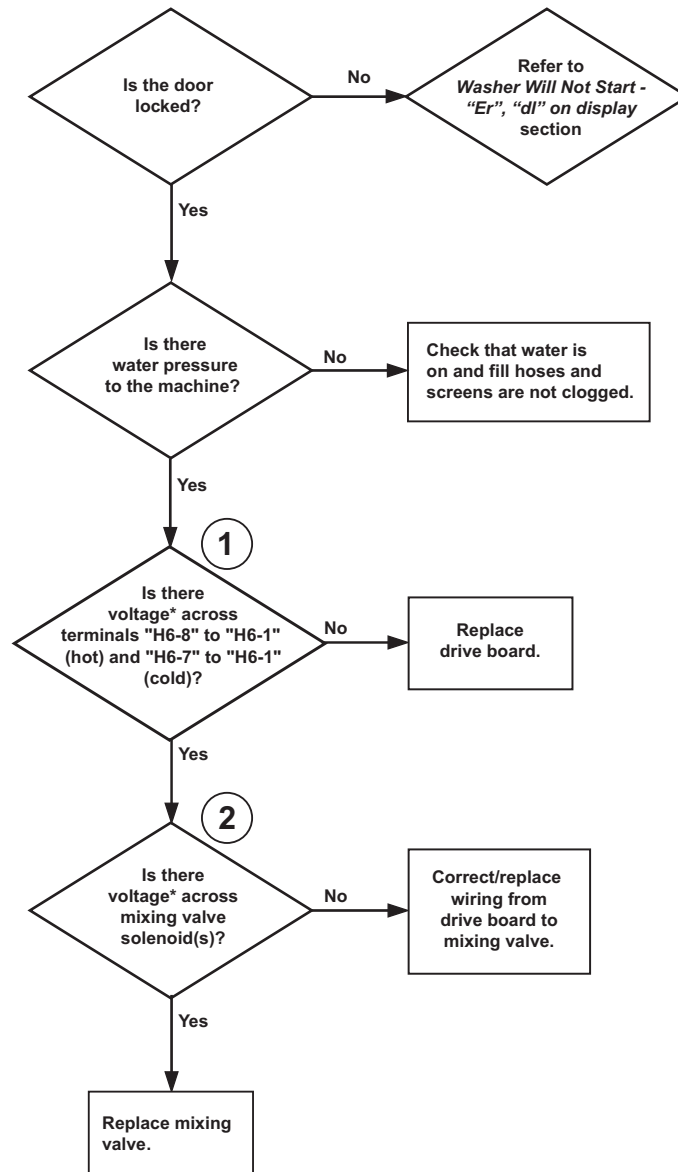

\*Refer to machine serial plate for correct voltage.

FLW1822S

# Washer Will Not Fill (Machine empty, No "Er", "PS" on Display)

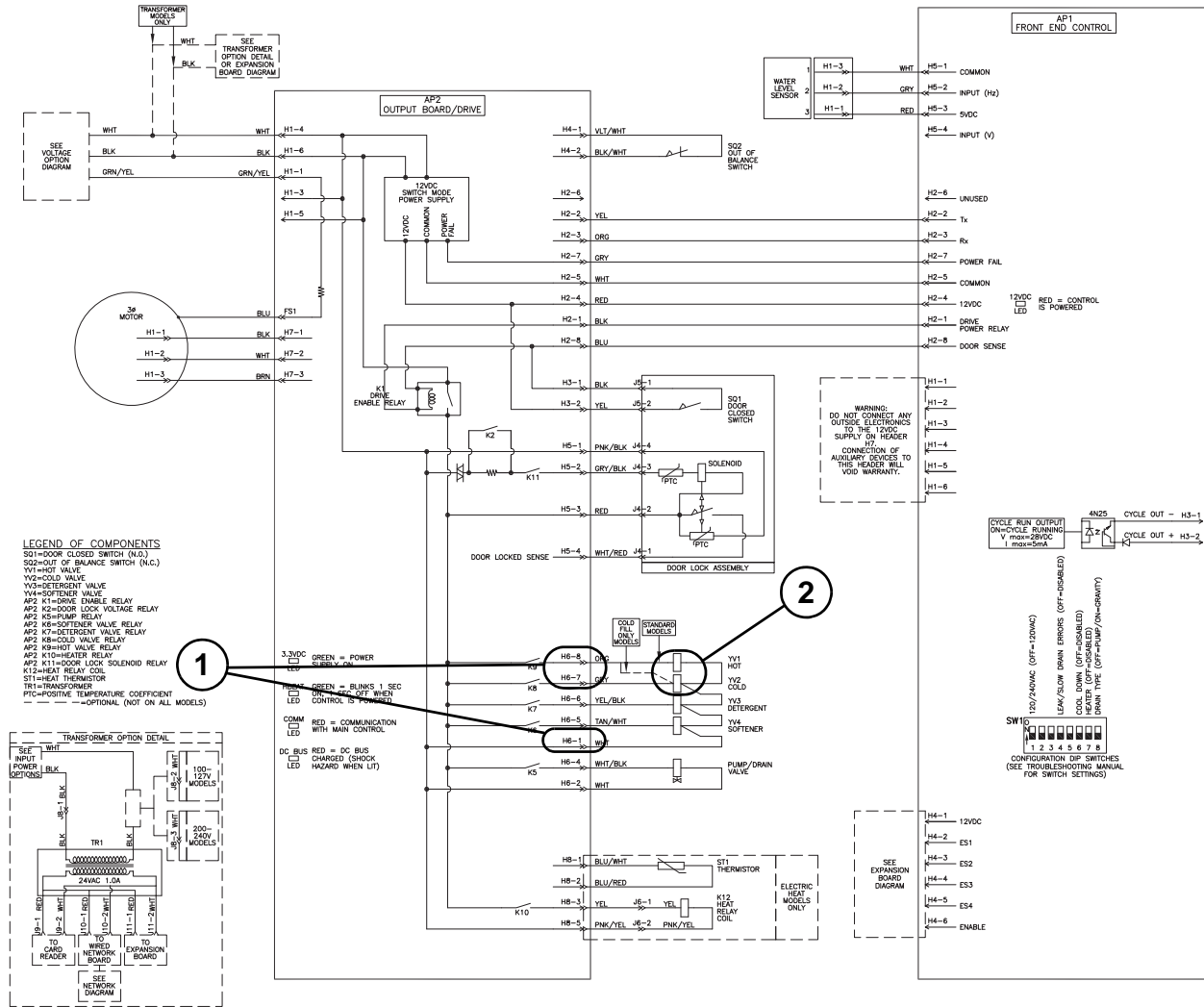

FLW1817S

# 17. Washer Overflows

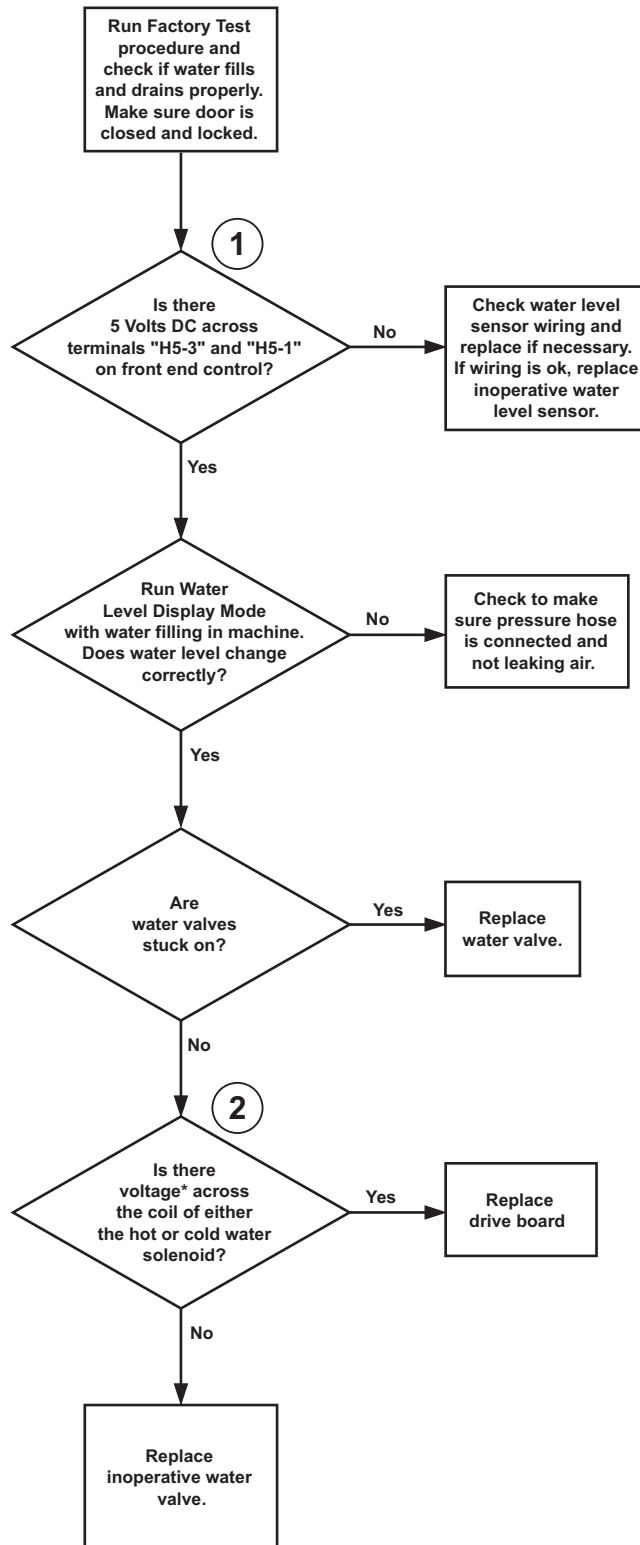

\*Refer to machine serial plate for correct voltage.

FLW1818S

# Washer Overflows

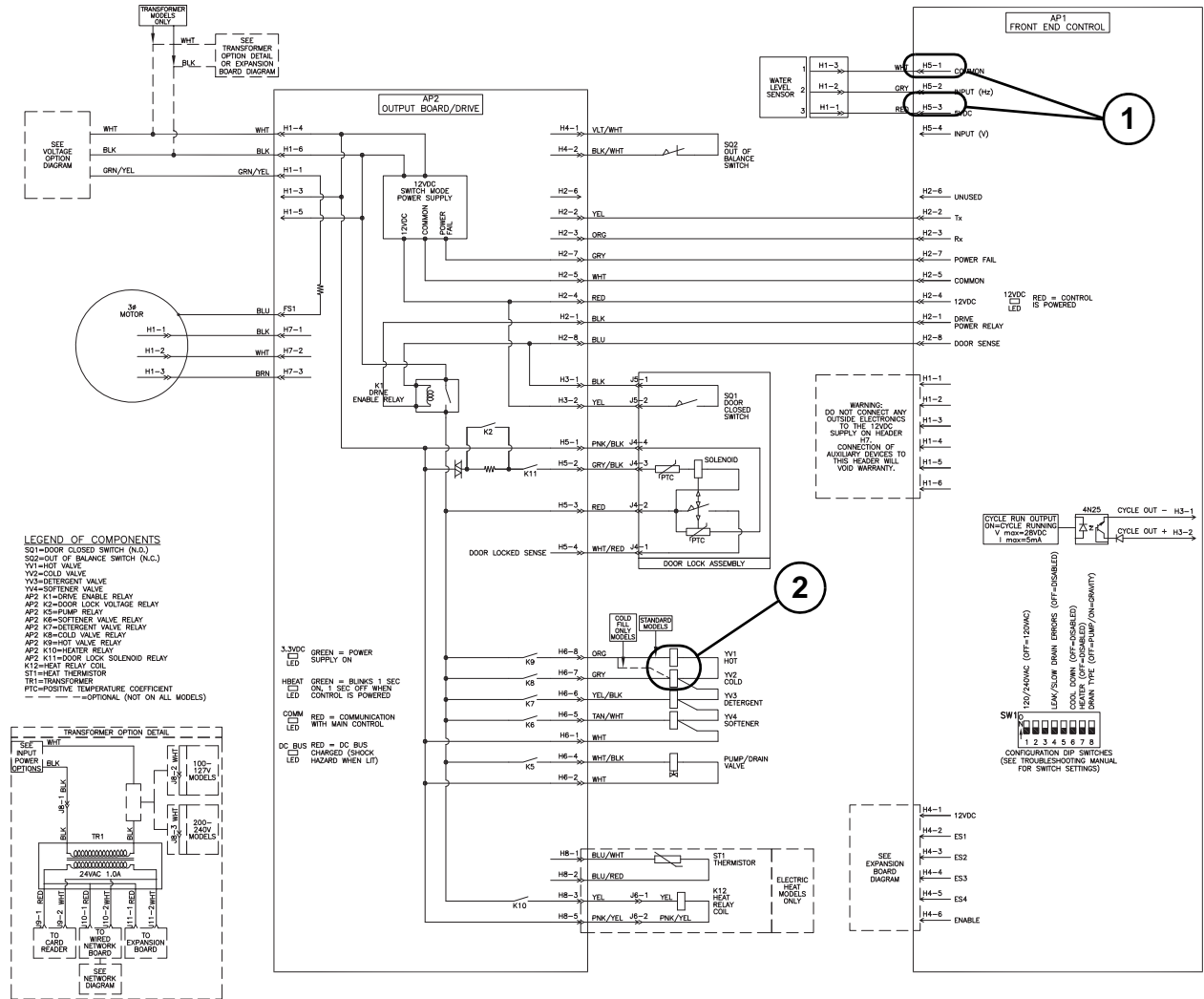

FLW1817S

# 18. Pump or Drain Valve Does Not Operate

**NOTE: Check at beginning of spin/drain portion of cycle.**

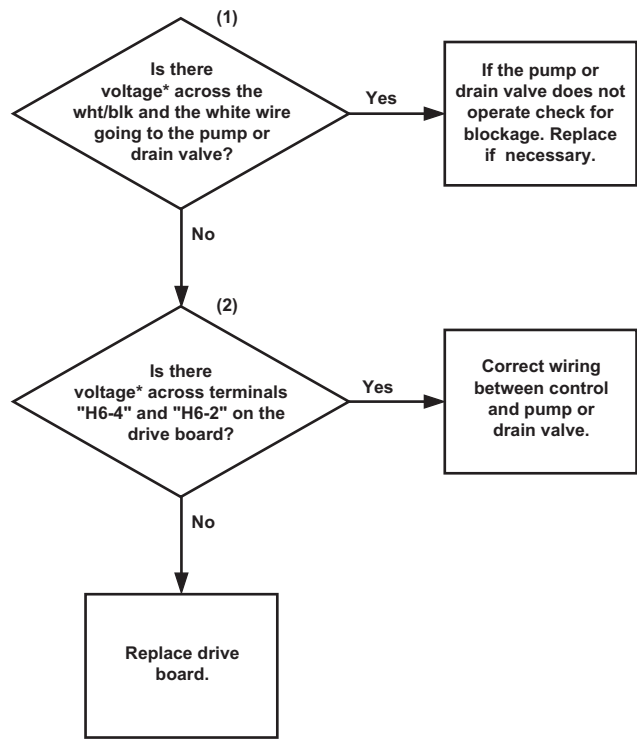

\*Refer to machine serial plate for correct voltage.

FLW1803S

# Pump or Drain Valve Does Not Operate

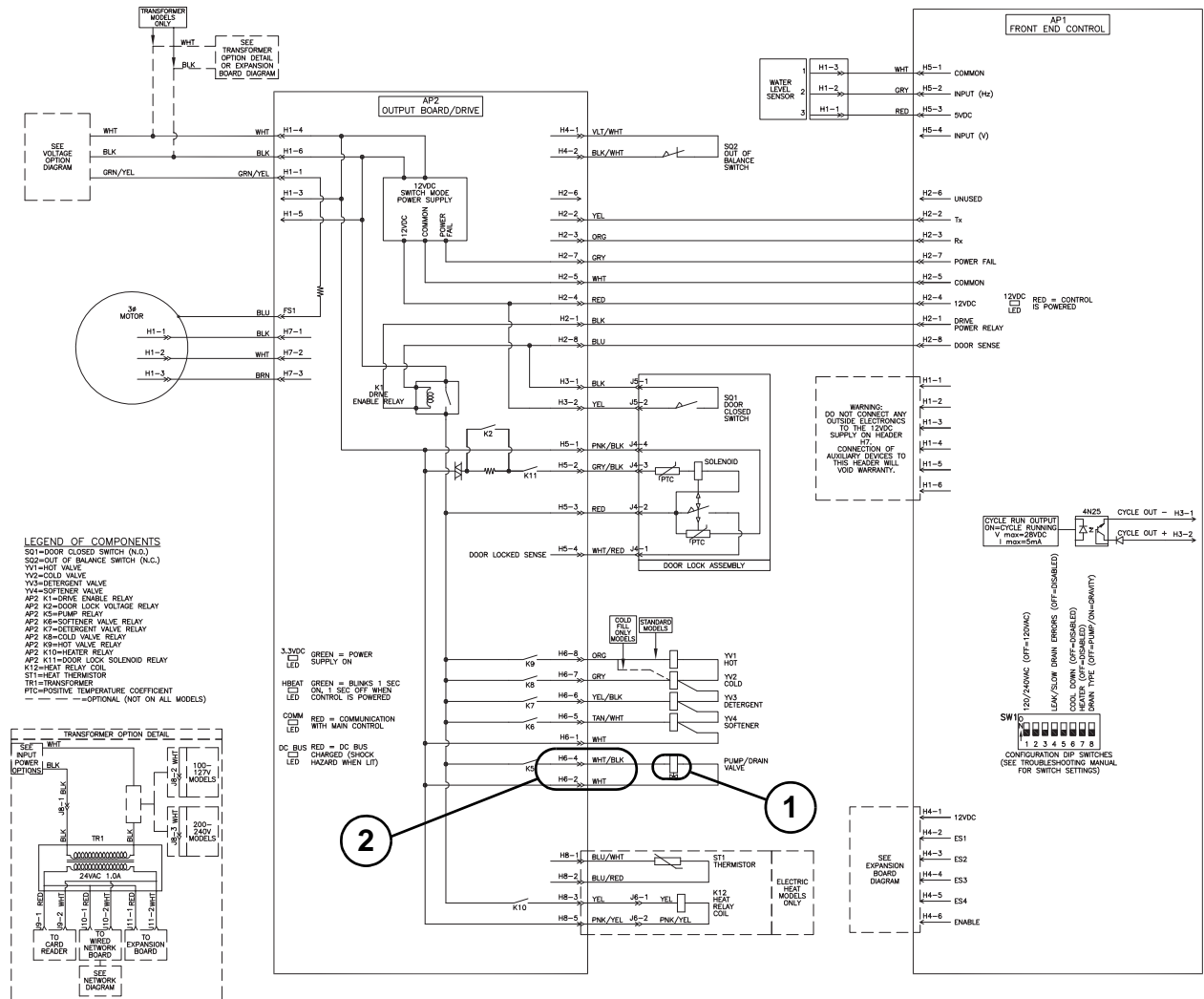

## 19. Motor Does Not Run (“Ed”, “29” on Display)

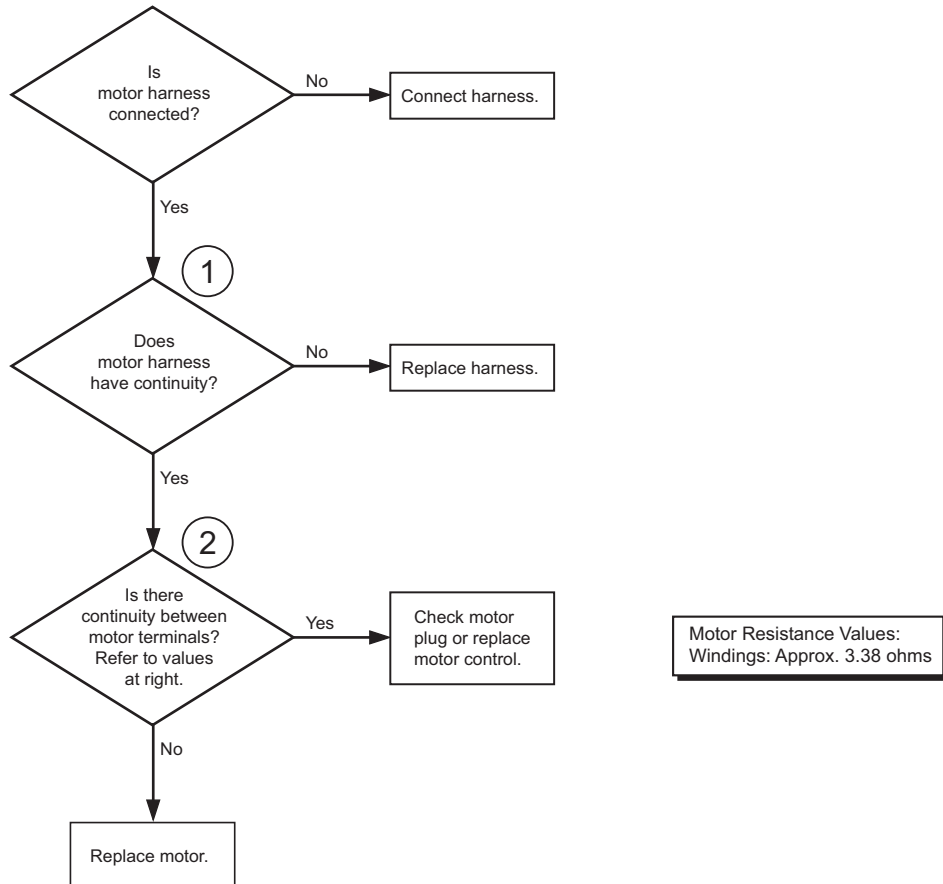

FLW1804S

Motor Does Not Run ("Ed", "29" on Display)

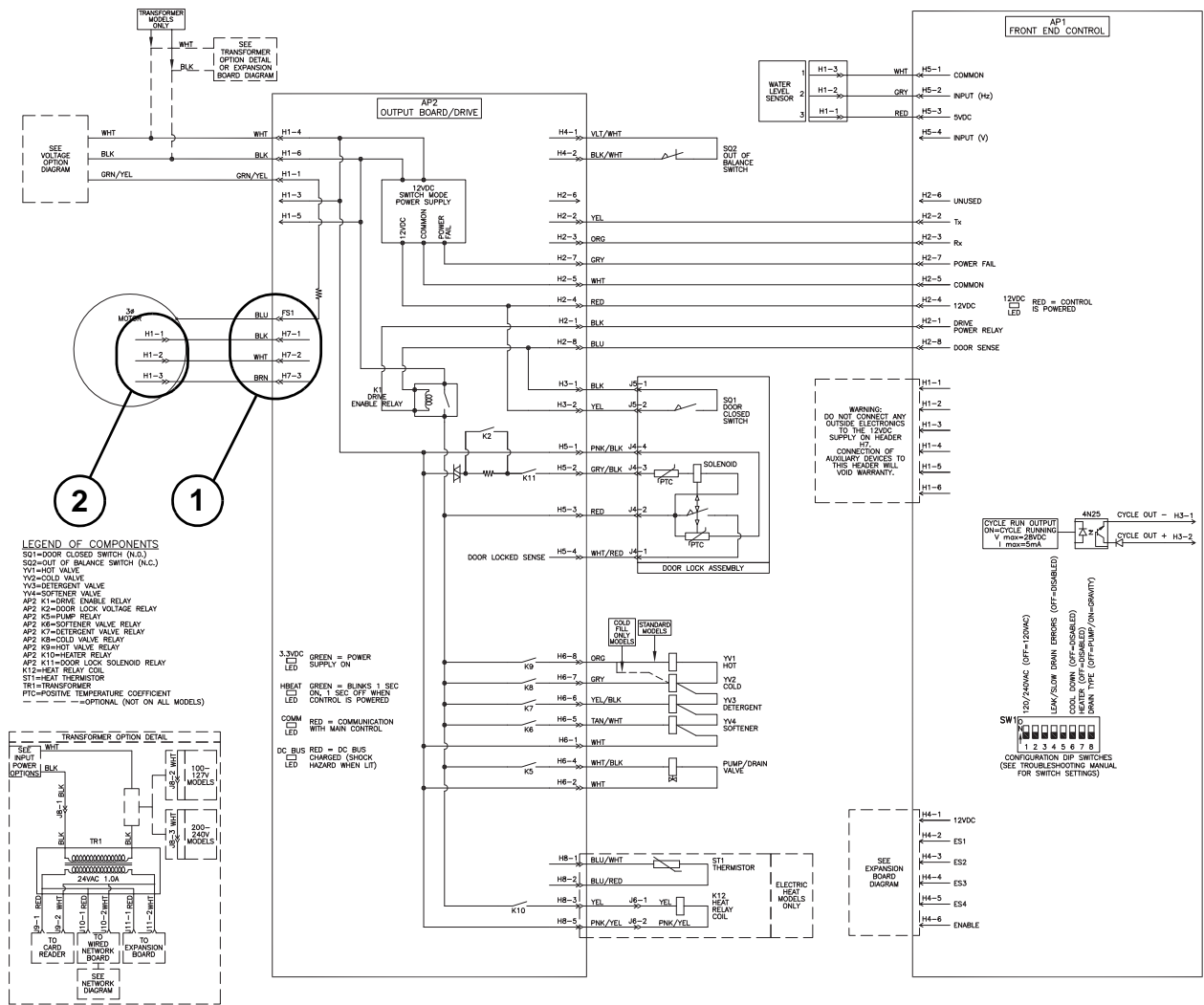

FLW1817S



## 20. Washer Will Not Heat (Models Equipped with Heater) ("Er", "oP" or "Er", "SH" Displayed)

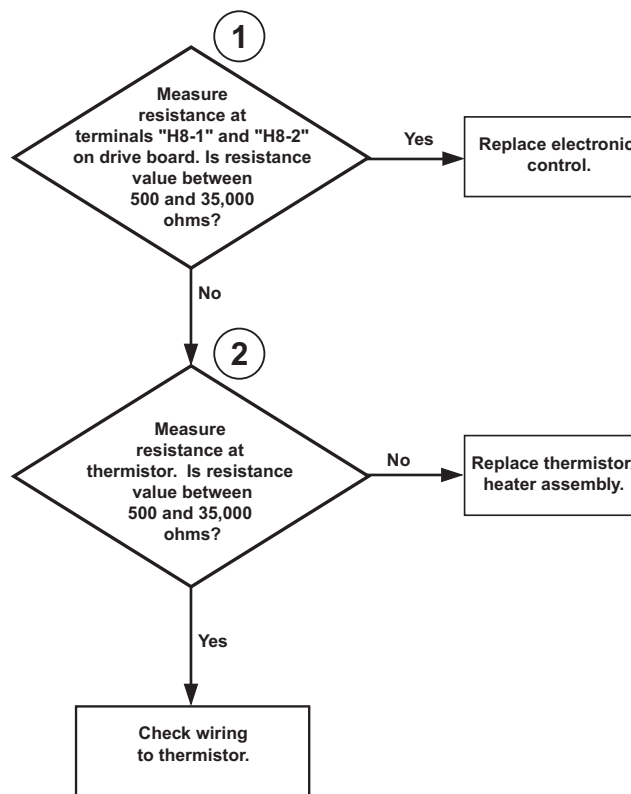

FLW1805S

# Washer Will Not Heat (Models Equipped with Heater) ("Er", "oP" or "Er", "SH" Displayed)

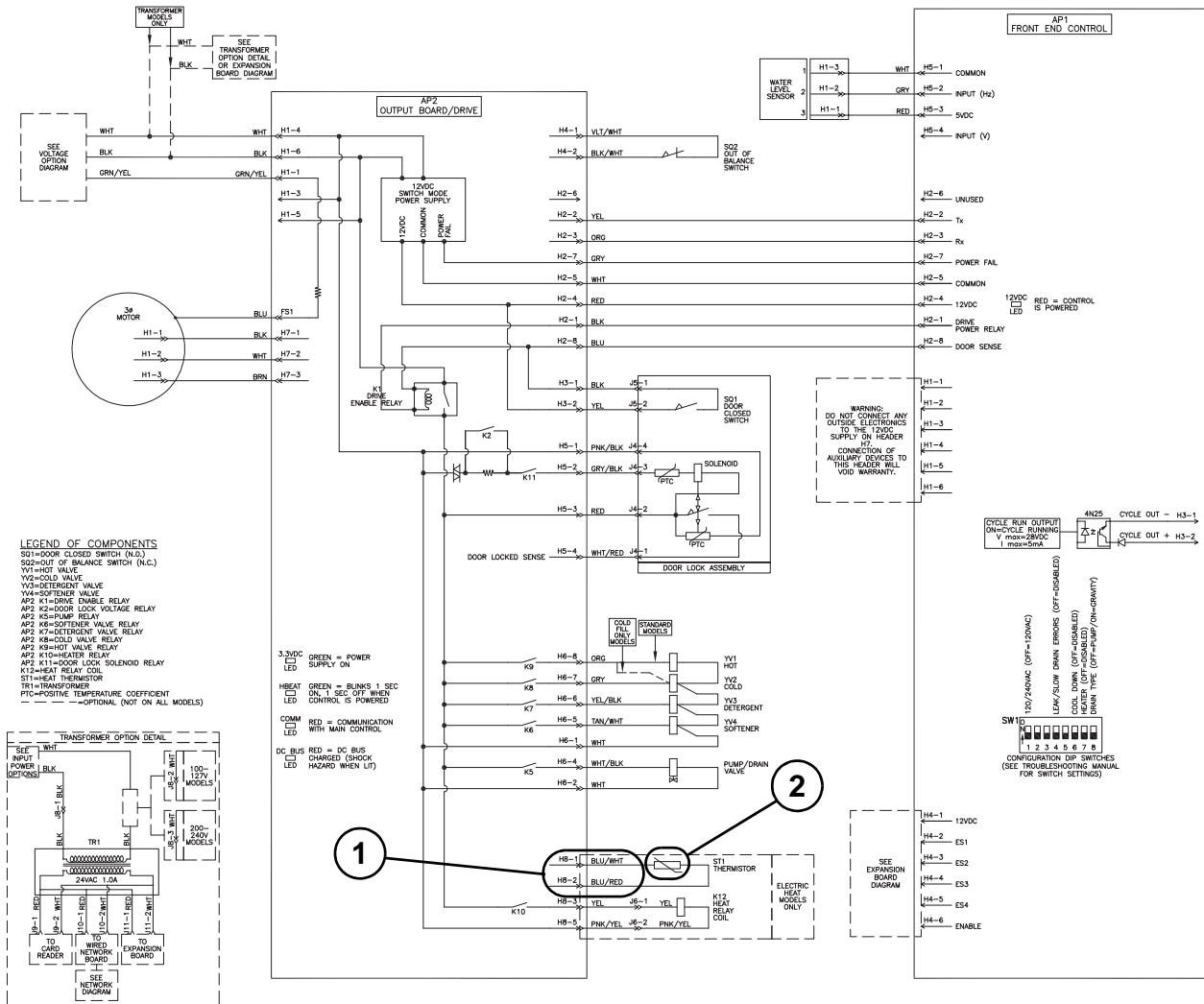

FLW18175

## 21. Washer Will Not Heat (Models Equipped with Heater)

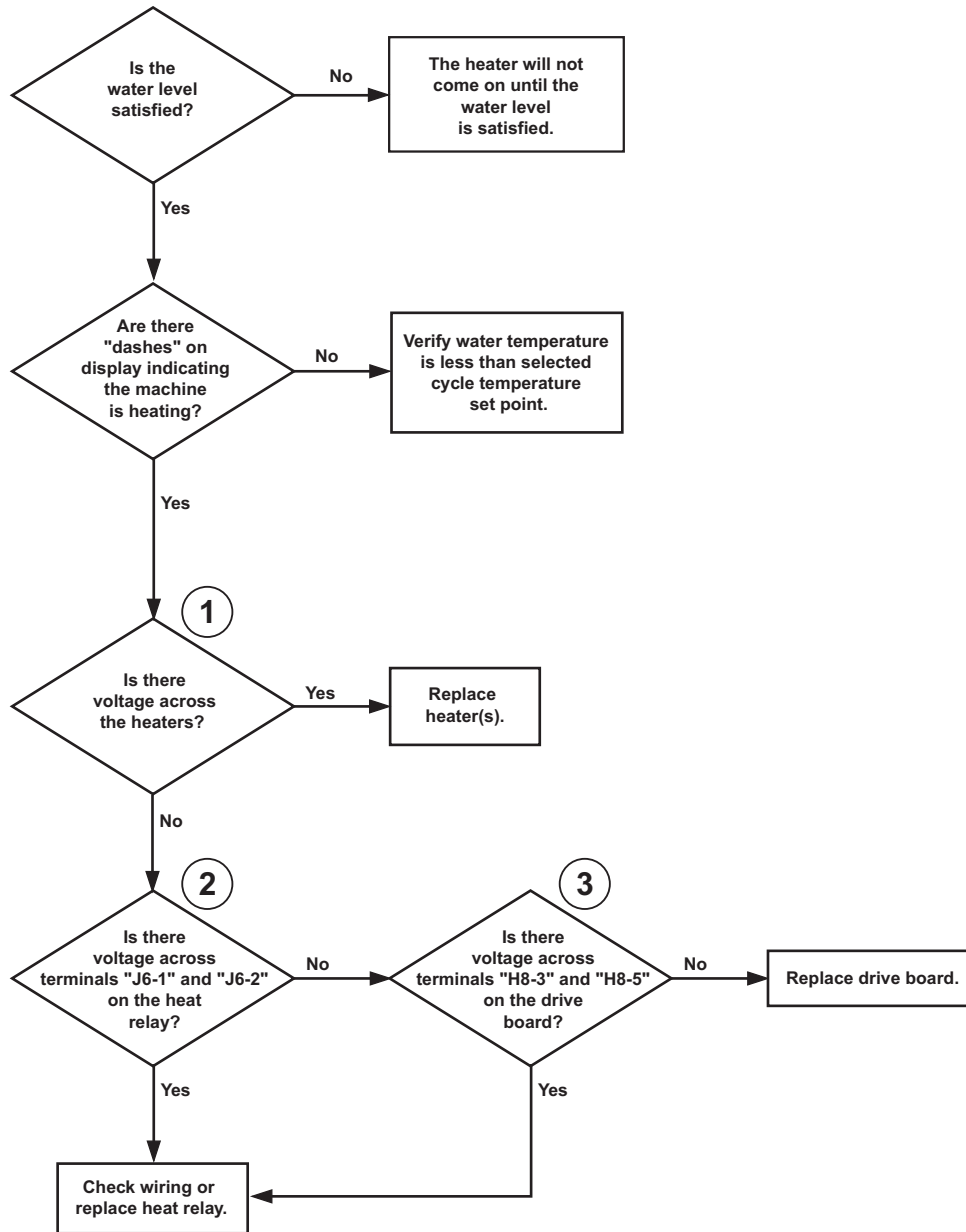

FLW1806S

**NOTE:** Resistance of heater element terminals when not connected should be greater than 0 (Zero) ohms and less 500 ohms.

# Washer Will Not Heat (Models Equipped with Heater)

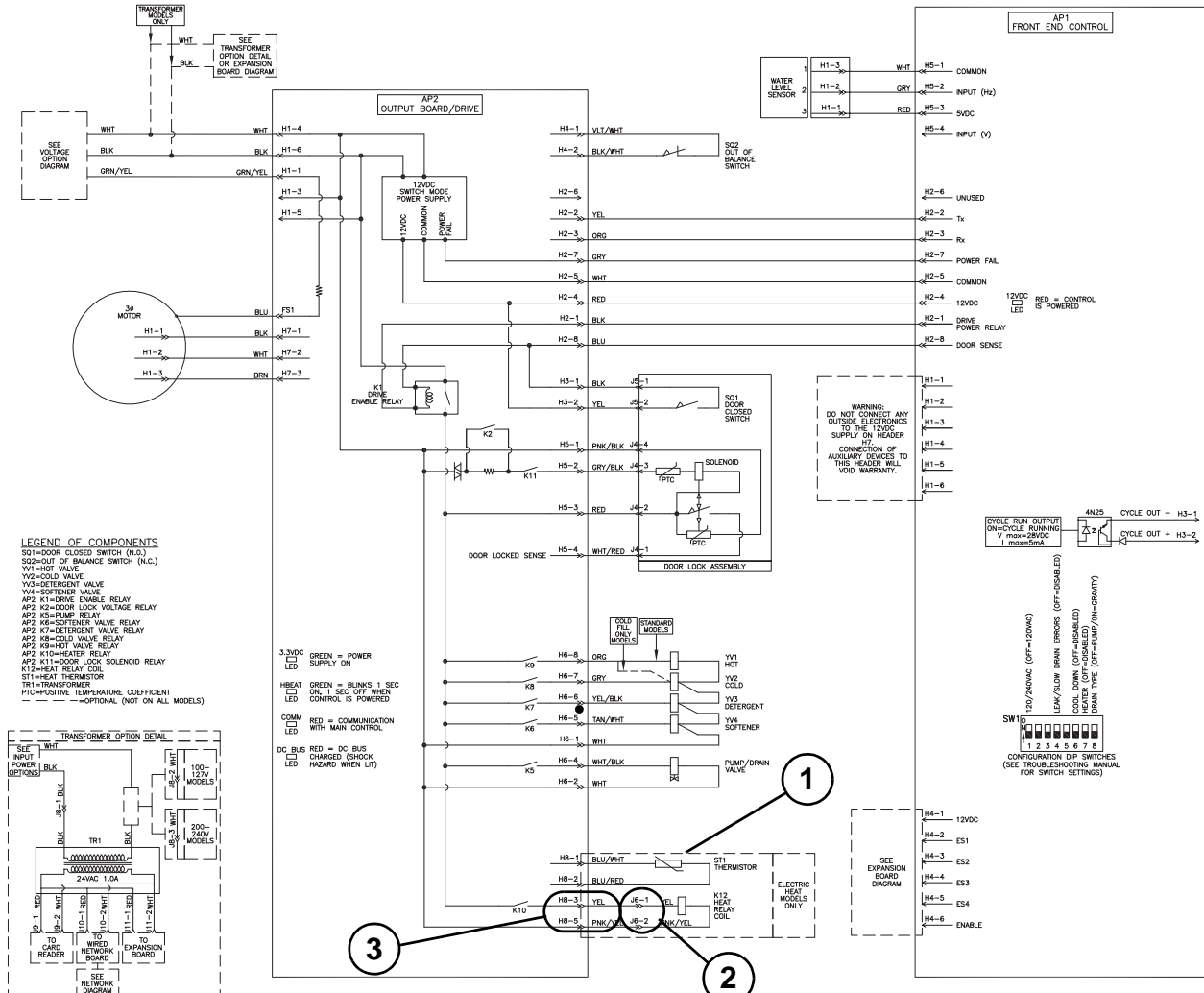

<p><b>WARNING</b></p> <p>Some internal parts are not grounded and may present a risk of electrical shock when servicing. <b>PERSONNEL DO NOT</b> contact the motor, motor control, or drain valve when the machine is plugged in.</p>	<p><b>WARNING</b></p> <p>Failure to install, maintain, and/or operate this machine according to manufacturer's instructions may result in conditions which can produce bodily injury and/or property damage.</p>	<p><b>NOTE</b></p> <p>POWER SUPPLY WIRING MUST HAVE CORRECT POLARITY AND GROUNDING FOR THE UNIT TO OPERATE CORRECTLY.</p>	<p><b>ATTENTION</b></p> <p>Certains pièces internes ne sont pas fondées et peuvent présenter un risque de choc électrique lors de l'entretien. Personnel de service, de ne pas contacter le moteur, le contrôle moteur, ou le robinet de vidange lorsque l'appareil est branché.</p>	<p><b>AVERTISSEMENT</b></p> <p>Si vous n'installez pas et/ou n'effectuez pas les opérations d'entretien et/ou ne faites pas fonctionner cette machine conformément aux instructions du fabricant, vous favorisez des situations dangereuses tant au niveau de blessures corporelles que celle de dommages à la propriété qui pourraient en résulter.</p>	<p><b>REMARQUE</b></p> <p>Le câblage d'alimentation électrique doit être correctement polarisé et mis à la terre pour que l'appareil fonctionne correctement.</p>
---	--	---	--	--	---

FLW18175

# Section 5 Adjustments



## WARNING

To reduce the risk of electric shock, fire, explosion, serious injury or death:

- Disconnect electric power to the washer before servicing.
- Never start the washer with any guards/panels removed.
- Whenever ground wires are removed during servicing, these ground wires must be reconnected to ensure that the washer is properly grounded.
- Motor not grounded! Disconnect electric power before servicing motor.

W485

**IMPORTANT:** When reference is made to directions (right or left) in this manual, it is from operator's position facing front of washer.

## 22. Cabinet Leveling Legs

- Place washer in position on a solid, sturdy and level floor. Installing the washer on any type of carpeting, soft tile, a platform, or other weak support structures is not recommended.
- Place level on washer, refer to *Figure 3*, and check if washer is level from side to side and front to back.

**NOTE:** Level must rest on raised portion of top panel. Refer to *Figure 3*.

- If washer is not level, tilt washer to access front and rear leveling legs. For easier access to leveling legs, prop up washer with wooden block. Refer to *Figure 3*.
- Loosen locknuts and adjust the leveling legs until the washer is level from side to side and front to back (using a level). **Make sure washer does not rock.** Refer to *Figure 3*.

- Tighten the locknuts securely against the washer base. If the locknuts are not tight, washer will move out of position during operation.



## CAUTION

**DO NOT** slide washer across floor if the leveling legs have been extended, as legs and base could become damaged.

W248



## CAUTION

**Use of the dispenser drawer or washer door as a handle in the transportation of the washer may cause damage to the dispenser or door.**

W185

- Place rubber feet on all four leveling legs. Refer to *Figure 3*.
- Verify that washer doesn't rock.

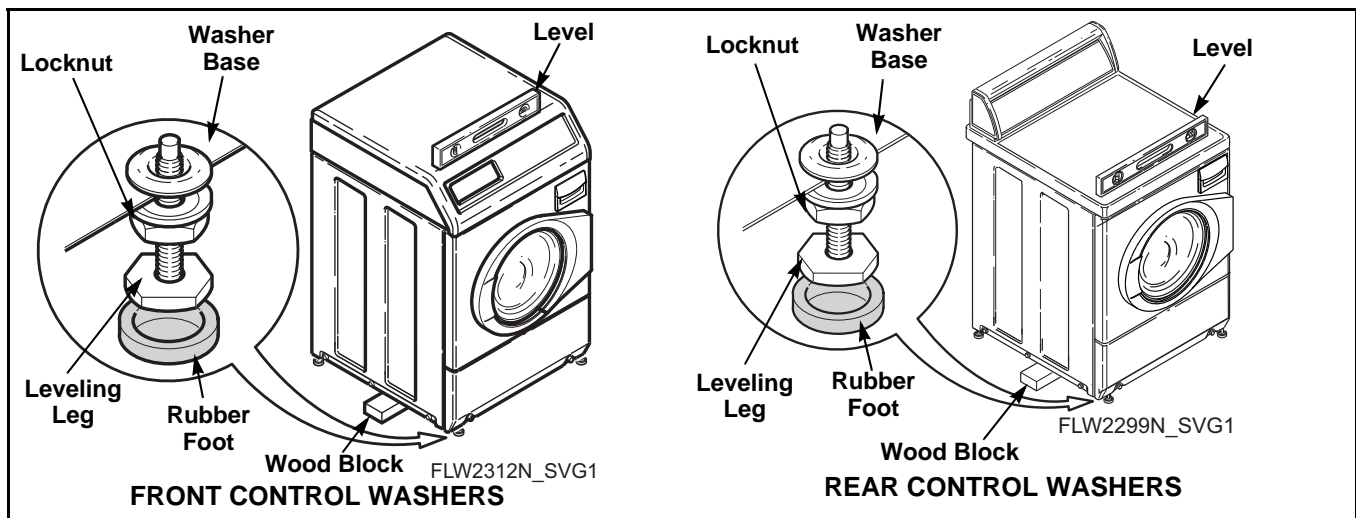

Figure 3



## WARNING

To reduce the risk of electric shock, fire, explosion, serious injury or death:

- Disconnect electric power to the washer before servicing.
- Never start the washer with any guards/panels removed.
- Whenever ground wires are removed during servicing, these ground wires must be reconnected to ensure that the washer is properly grounded.
- Motor not grounded! Disconnect electric power before servicing motor.

W485

### 23. Loading Door

- Open loading door.
- The loading door can be adjusted up or down somewhat by loosening screws holding door hinge to front panel, then raise or lower door before retightening screws. Refer to *Figure 4*.

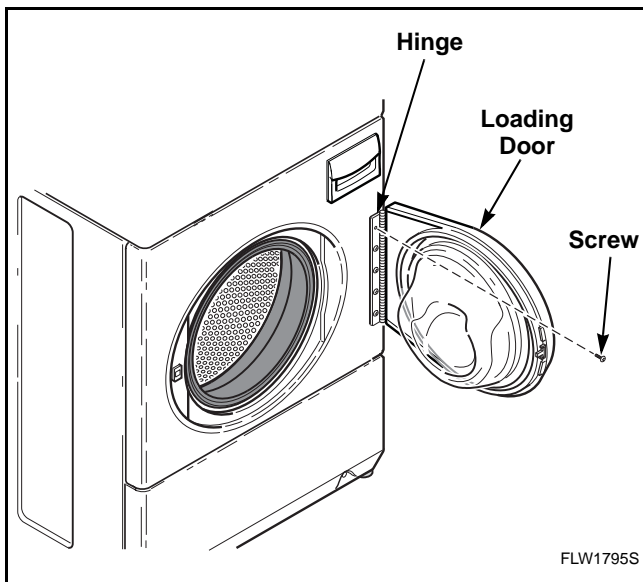

Figure 4



## WARNING

To reduce the risk of electric shock, fire, explosion, serious injury or death:

- Disconnect electric power to the washer before servicing.
- Never start the washer with any guards/panels removed.
- Whenever ground wires are removed during servicing, these ground wires must be reconnected to ensure that the washer is properly grounded.
- Motor not grounded! Disconnect electric power before servicing motor.

W485

## 24. Motor Belt Tension

**NOTE:** Belt adjustment procedures are done through front of washer, however, as an option, washer can be moved from its location and belt adjustment can be done through lower access panel opening at rear of washer.

- While supporting lower front access panel, remove two screws from bottom edge of access panel and remove panel.
- Working through the lower front access door opening, place a locking pliers on the metal rod and loosen the two adjusting bolts. Refer

to *Figure 5*. Repeat procedure to loosen the two pivot bolts. Refer to *Figure 5*.

- Pull down on motor to increase belt tension. Use a Burroughs belt gauge to obtain proper tension. Proper belt tension is obtained when belt can be deflected approximately 1/4 inch (6.35 mm) from normal position when moderate pressure 50 to 60 pounds (22.68 to 27.22 Kg) is applied to a point midway between pulleys. Refer to *Figure 5*.
- After proper belt tension has been obtained, tighten belt adjusting bolts firmly, then tighten pivot bolts. Refer to *Figure 5*.

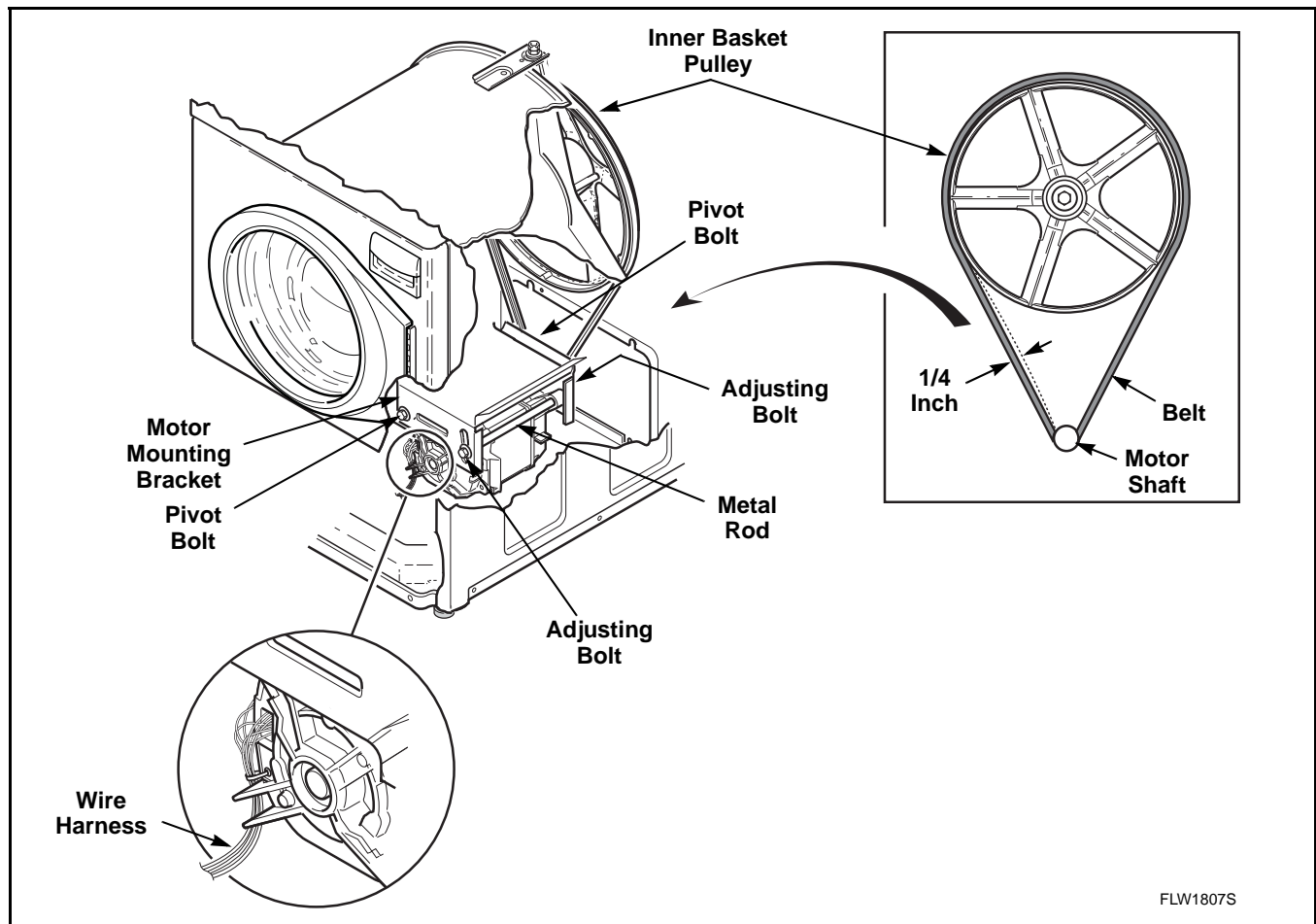

Figure 5



## WARNING

To reduce the risk of electric shock, fire, explosion, serious injury or death:

- Disconnect electric power to the washer before servicing.
- Never start the washer with any guards/panels removed.
- Whenever ground wires are removed during servicing, these ground wires must be reconnected to ensure that the washer is properly grounded.
- Motor not grounded! Disconnect electric power before servicing motor.

W485

## 25. Door Catch

**NOTE: When repairing a broken or inoperative No. 802803 Door Catch, proceed as follows:**

- a. Open loading door.
- b. Remove 11 T-20 Torx head screws holding outer door bezel to inner door bezel. Refer to *Figure 6*.
- c. Pull hinge side of outer bezel away from door and slide forward. Refer to *Figure 6*.
- d. Remove two screws and nuts holding door catch to door and remove door catch.
- e. Install new door catch and tighten screws and nuts to the point of being snug.
- f. Adjust door catch so the outside edge is aligned with the edge of the lock. Refer to *Figure 7*.

- g. Visually check that the door catch properly engages the funnel of the door latch/switch assembly. Refer to *Figure 7*.
- h. Recheck the alignment in Step f. Adjust if needed.
- i. Torque the two nuts to approximately 20 inch pounds (2.25 Nm).
- j. Reinstall outer door bezel by aligning outer bezel tabs with cut aways on inner bezel and sliding outer bezel into position. Refer to *Figure 6*.
- k. Replace 11 screws holding outer door bezel to inner door bezel.

**IMPORTANT: Do not overtighten screws or bezel holes will strip.**

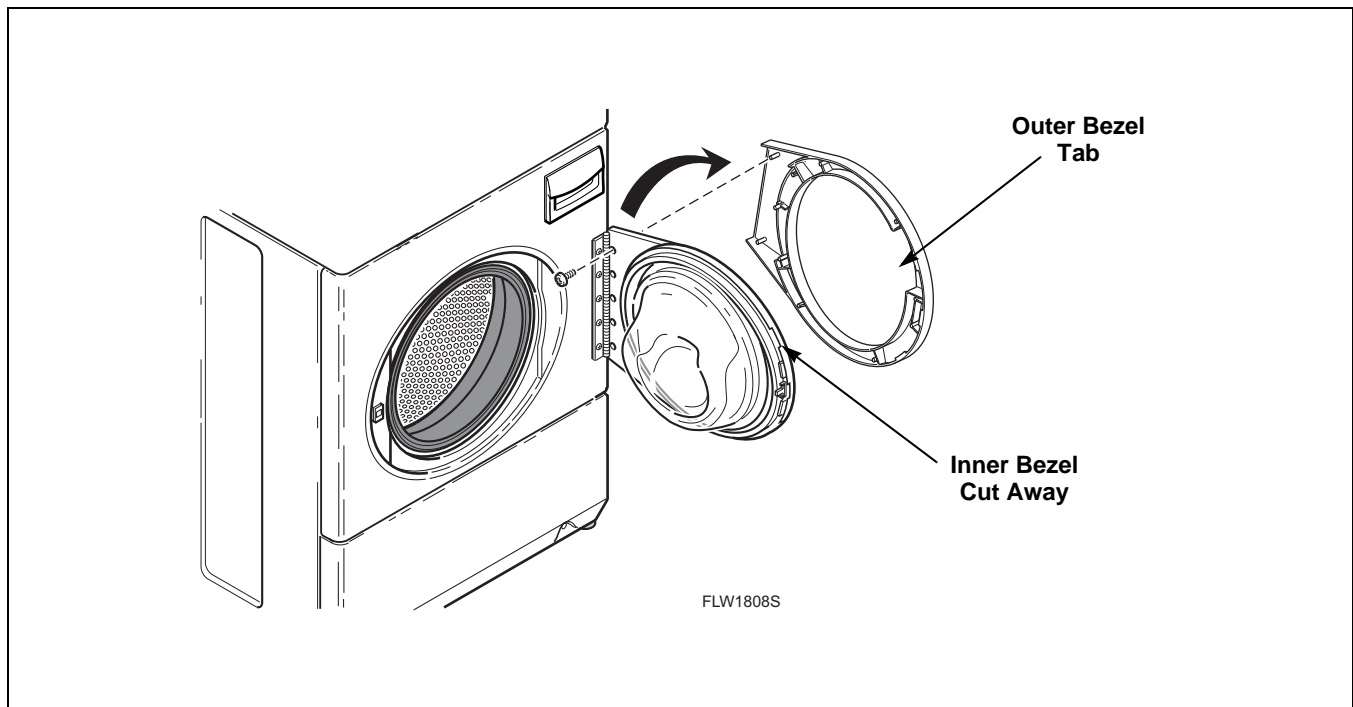

Figure 6





## WARNING

To reduce the risk of electric shock, fire, explosion, serious injury or death:

- Disconnect electric power to the washer before servicing.
- Never start the washer with any guards/panels removed.
- Whenever ground wires are removed during servicing, these ground wires must be reconnected to ensure that the washer is properly grounded.
- Motor not grounded! Disconnect electric power before servicing motor.

W485

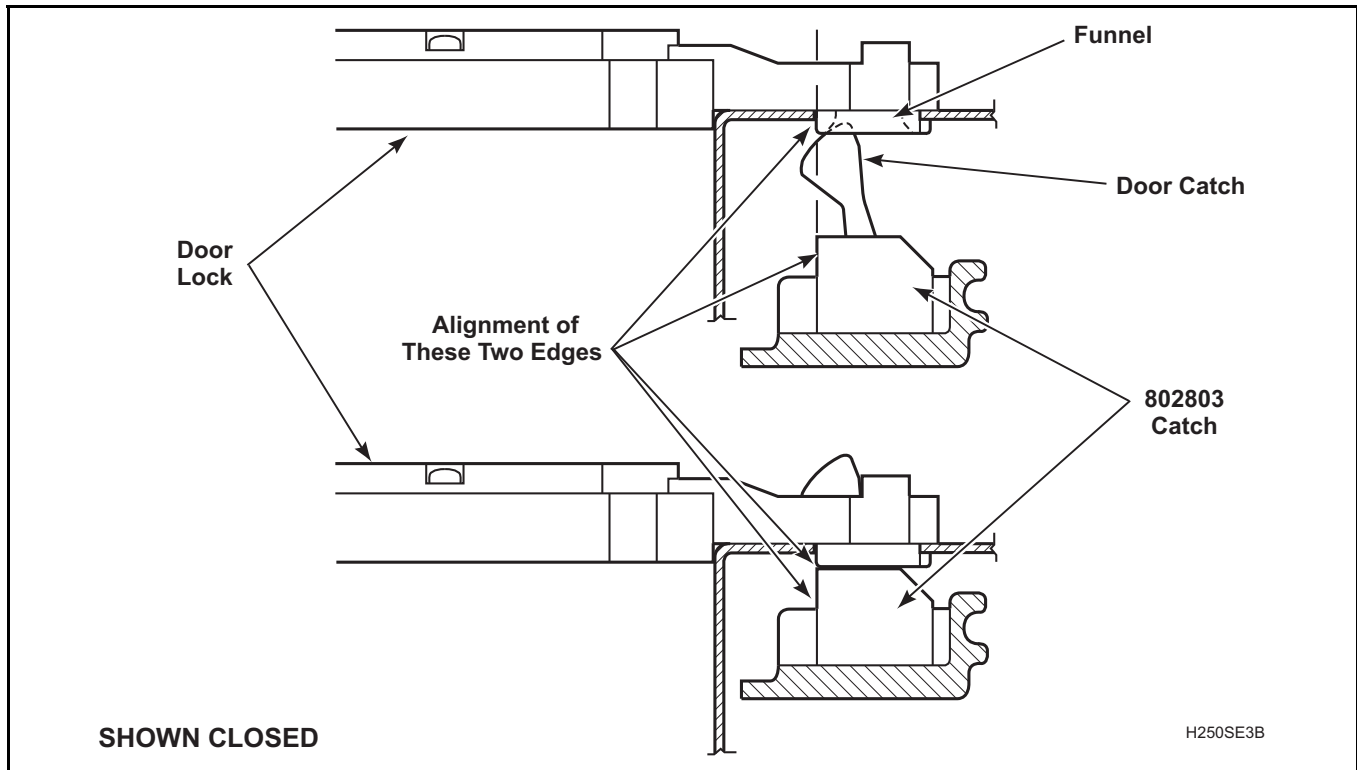



Figure 7

# Section 6

## Cycle Sequence Charts

	WARNING
<p>To reduce the risk of electric shock, fire, explosion, serious injury or death:</p> <ul style="list-style-type: none"> <li>• Disconnect electric power to the washer before servicing.</li> <li>• Never start the washer with any guards/panels removed.</li> <li>• Whenever ground wires are removed during servicing, these ground wires must be reconnected to ensure that the washer is properly grounded.</li> <li>• Motor not grounded! Disconnect electric power before servicing motor.</li> </ul>	
W485	

The cycle stages are dependent on the cycle, selections and options chosen. Not all models include all sets of these features.

The times listed are approximate and will vary depending on the selections and options chosen.

**NOTE: The rinse water temperature will be cold, including when optional rinses are selected.**

**NOTE: If No Spin is selected, all spin stages are one minute of drain and tumble.**

\*Time if No Spin is selected as Spin Speed.

### Normal Eco Wash Cycle (models AFNE9BSP303XN26, AFNE9BSP303XW26 and models with “A” in the 12<sup>th</sup> character of the model number)

Stage	Step	Time	Default Time	Speed	Dispensers	Water Valves	Pump	Gravity Drain
INITIAL DRAIN	Drain	0:10	0:10	Off	Off	Off	C	Open
WETTING	Fill/Agitate	2:30	2:30	WA	Det/Bl, ES1	H, W, C, TC	Off	Closed
SOAK (optional)	Soak Fill/Agitate	3:00	0:00	LA, Off	Off	H, W, C, TC	Off	Closed
	Soak Soak	30:00	0:00	SA, Off	Off	H, W, C, TC	Off	Closed
	Soak Distribute/Pump	1:00	0:00	D	Off	Off	C	Open
PRE-WASH (optional)	Prewash Fill/Agitate	6:00	0:00	WA	Off	H, W, C, TC	Off	Closed
	Prewash Distribute/Pump	1:00	0:00	D	Off	Off	C	Open
HEAT (heater models only)	Heat Fill/Agitate	2:00	0:00	WA	Det/Bl, ES1	H, W, C, TC	Off	Closed
	Heat Heater	28:00	0:00	WA	Off	H, W, C, TC	Off	Closed

(continued)

	WARNING
<p>To reduce the risk of electric shock, fire, explosion, serious injury or death:</p> <ul style="list-style-type: none"> <li>• Disconnect electric power to the washer before servicing.</li> <li>• Never start the washer with any guards/panels removed.</li> <li>• Whenever ground wires are removed during servicing, these ground wires must be reconnected to ensure that the washer is properly grounded.</li> <li>• Motor not grounded! Disconnect electric power before servicing motor.</li> </ul>	
W485	

(continued)

Stage	Step	Time	Default Time	Speed	Dispensers	Water Valves	Pump	Gravity Drain
WASH	Wash Fill/Agitate	50:00, 65:00, 80:00, 95:00	65:00	WA	Det/Bl, ES1	H, W, C, TC	Off	Closed
	Wash Distribute	0:00	0:00	D	Off	Off	C	Open
	Wash Spin	6:35	6:35	RS	Off	Off	C	Open
RINSE	Rinse Fill/Agitate	6:25	3:25	WA	Det/Bl	TC	Off	Closed
	Rinse Distribute	0:00	0:00	D	Off	Off	C	Open
	Rinse Spin	6:35	6:35	RS	Off	Off	C	Open
SECOND RINSE (optional)	Second Rinse Fill/Agitate	6:25	0:00	WA	Det/Bl	TC	Off	Closed
	Second Rinse Distribute	0:00	0:00	D	Off	Off	C	Open
	Second Rinse Spin	6:35	0:00	RS	Off	Off	C	Open
THIRD RINSE 1	Third Rinse 1 Fill/Agitate	6:25	0:00	WA	Det/Bl	TC	Off	Closed
	Third Rinse 1 Distribute	0:00	0:00	D	Off	Off	C	Open
	Third Rinse 1 Spin	6:35	0:00	RS	Off	Off	C	Open

(continued)

Cycle Sequence Charts

	WARNING
<p>To reduce the risk of electric shock, fire, explosion, serious injury or death:</p> <ul style="list-style-type: none"> <li>• Disconnect electric power to the washer before servicing.</li> <li>• Never start the washer with any guards/panels removed.</li> <li>• Whenever ground wires are removed during servicing, these ground wires must be reconnected to ensure that the washer is properly grounded.</li> <li>• Motor not grounded! Disconnect electric power before servicing motor.</li> </ul>	
W485	

(continued)

Stage	Step	Time	Default Time	Speed	Dispensers	Water Valves	Pump	Gravity Drain
THIRD RINSE 2	Third Rinse 2 Fill/Agitate	6:25	0:00	WA	Det/Bl	TC	Off	Closed
	Third Rinse 2 Distribute	0:00	0:00	D	Off	Off	C	Open
	Third Rinse 2 Spin	6:35	0:00	RS	Off	Off	C	Open
FINAL RINSE	Final Fill/Agitate	6:25	3:25	WA	Det/Bl, Soft, ES2	TC	Off	Closed
	Final Distribute	0:00	0:00	D	Off	Off	C	Open
	Final Rinse Spin	0:00	0:00	RS	Off	Off	C	Open
FINAL SPIN	Final High Spin	9:00	9:00	HS*	Off	Off	C	Open
	Breakaway	2:20	2:20	BA	Off	Off	C	Open

Default Total Cycle Time: 131:00

	WARNING
<p>To reduce the risk of electric shock, fire, explosion, serious injury or death:</p> <ul style="list-style-type: none"> <li>• Disconnect electric power to the washer before servicing.</li> <li>• Never start the washer with any guards/panels removed.</li> <li>• Whenever ground wires are removed during servicing, these ground wires must be reconnected to ensure that the washer is properly grounded.</li> <li>• Motor not grounded! Disconnect electric power before servicing motor.</li> </ul>	
W485	

**Normal Eco Wash Cycle (all other models)**

Stage	Step	Time	Default Time	Speed	Dispensers	Water Valves	Pump	Gravity Drain
INITIAL DRAIN	Drain	0:10	0:10	Off	Off	Off	C	Open
WETTING	Fill/Agitate	2:30	2:30	WA	Det/Bl, ES1	H, W, C, TC	Off	Closed
SOAK (optional)	Soak Fill/Agitate	3:00	0:00	LA, Off	Off	H, W, C, TC	Off	Closed
	Soak Soak	30:00	0:00	SA, Off	Off	H, W, C, TC	Off	Closed
	Soak Distribute/Pump	1:00	0:00	D	Off	Off	C	Open
PRE-WASH (optional)	Prewash Fill/Agitate	6:00	0:00	RA	Off	H, W, C, TC	Off	Closed
	Prewash Distribute/Pump	1:00	0:00	D	Off	Off	C	Open
HEAT (heater models only)	Heat Fill/Agitate	2:00	0:00	RA	Det/Bl, ES1	H, W, C, TC	Off	Closed
	Heat Heater	28:00	0:00	RA	Off	H, W, C, TC	Off	Closed
WASH	Wash Fill/Agitate	10:00, 14:00, 18:00, 22:00	14:00	RA	Det/Bl, ES1	H, W, C, TC	Off	Closed
	Wash Distribute	0:00	0:00	D	Off	Off	C	Open
	Wash Spin	4:35	4:35	RS	Off	Off	C	Open

(continued)

Cycle Sequence Charts

	WARNING
<p>To reduce the risk of electric shock, fire, explosion, serious injury or death:</p> <ul style="list-style-type: none"> <li>• Disconnect electric power to the washer before servicing.</li> <li>• Never start the washer with any guards/panels removed.</li> <li>• Whenever ground wires are removed during servicing, these ground wires must be reconnected to ensure that the washer is properly grounded.</li> <li>• Motor not grounded! Disconnect electric power before servicing motor.</li> </ul>	
W485	

(continued)

Stage	Step	Time	Default Time	Speed	Dispensers	Water Valves	Pump	Gravity Drain
RINSE	Rinse Fill/Agitate	3:25	3:25	RA	Det/Bl	TC	Off	Closed
	Rinse Distribute	0:00	0:00	D	Off	Off	C	Open
	Rinse Spin	4:35	4:35	RS	Off	Off	C	Open
SECOND RINSE (optional)	Second Rinse Fill/Agitate	3:25	0:00	RA	Det/Bl	TC	Off	Closed
	Second Rinse Distribute	0:00	0:00	D	Off	Off	C	Open
	Second Rinse Spin	4:35	0:00	RS	Off	Off	C	Open
THIRD RINSE 1 (optional)	Third Rinse 1 Fill/Agitate	3:25	0:00	RA	Det/Bl	TC	Off	Closed
	Third Rinse 1 Distribute	0:00	0:00	D	Off	Off	C	Open
	Third Rinse 1 Spin	4:35	0:00	RS	Off	Off	C	Open
THIRD RINSE 2 (optional)	Third Rinse 2 Fill/Agitate	3:25	0:00	RA	Det/Bl	TC	Off	Closed
	Third Rinse 2 Distribute	0:00	0:00	D	Off	Off	C	Open
	Third Rinse 2 Spin	4:35	0:00	RS	Off	Off	C	Open

(continued)

	WARNING
<p>To reduce the risk of electric shock, fire, explosion, serious injury or death:</p> <ul style="list-style-type: none"> <li>• Disconnect electric power to the washer before servicing.</li> <li>• Never start the washer with any guards/panels removed.</li> <li>• Whenever ground wires are removed during servicing, these ground wires must be reconnected to ensure that the washer is properly grounded.</li> <li>• Motor not grounded! Disconnect electric power before servicing motor.</li> </ul>	
W485	

(continued)

Stage	Step	Time	Default Time	Speed	Dispensers	Water Valves	Pump	Gravity Drain
FINAL RINSE	Final Fill/Agitate	3:25	3:25	RA	Det/Bl, Soft, ES2	TC	Off	Closed
	Final Distribute	0:00	0:00	D	Off	Off	C	Open
	Final Rinse Spin	0:00	0:00	RS	Off	Off	C	Open
FINAL SPIN	Final High Spin	9:00	9:00	HS*	Off	Off	C	Open
	Breakaway	2:20	2:20	BA	Off	Off	C	Open

Default Total Cycle Time: 44:00

### Perm Press Wash Cycle

Stage	Step	Time	Default Time	Speed	Dispensers	Water Valves	Pump	Gravity Drain
INITIAL DRAIN	Drain	0:10	0:10	Off	Off	Off	C	Open
WETTING	Fill/Agitate	2:30	2:30	WA	Det/Bl, ES1	H, W, C, TC	Off	Closed
SOAK (optional)	Soak Fill/Agitate	3:00	0:00	LA, Off	Off	H, W, C, TC	Off	Closed
	Soak Soak	30:00	0:00	SA, Off	Off	H, W, C, TC	Off	Closed
	Soak Distribute/Pump	1:00	0:00	D	Off	Off	C	Open
PRE-WASH (optional)	Prewash Fill/Agitate	6:00	0:00	RA	Off	H, W, C, TC	Off	Closed
	Prewash Distribute/Pump	1:00	0:00	D	Off	Off	C	Open

(continued)

Cycle Sequence Charts

	WARNING
<p><b>To reduce the risk of electric shock, fire, explosion, serious injury or death:</b></p> <ul style="list-style-type: none"> <li><b>Disconnect electric power to the washer before servicing.</b></li> <li><b>Never start the washer with any guards/panels removed.</b></li> <li><b>Whenever ground wires are removed during servicing, these ground wires must be reconnected to ensure that the washer is properly grounded.</b></li> <li><b>Motor not grounded! Disconnect electric power before servicing motor.</b></li> </ul>	
W485	

(continued)

Stage	Step	Time	Default Time	Speed	Dispensers	Water Valves	Pump	Gravity Drain
HEAT (heater models only)	Heat Fill/Agitate	2:00	0:00	RA	Det/Bl, ES1	H, W, C, TC	Off	Closed
	Heat Heater	28:00	0:00	RA	Off	H, W, C, TC	Off	Closed
WASH	Wash Fill/Agitate	8:00, 12:00, 16:00, 20:00	12:00	RA	Det/Bl, ES1	H, W, C, TC	Off	Closed
	Wash Distribute	0:00, 1:00*	0:00	D	Off	Off	C	Open
	Wash Spin	4:35, 0:00*	4:35	RS	Off	Off	P	Open
RINSE	Rinse Fill/Agitate	3:25	3:25	RA	Det/Bl	TC	Off	Closed
	Rinse Distribute	0:00, 1:00*	0:00	D	Off	Off	C	Open
	Rinse Spin	4:35, 0:00*	4:35	RS	Off	Off	C	Open
SECOND RINSE (optional)	Second Rinse Fill/Agitate	3:25	0:00	RA	Det/Bl	TC	Off	Closed
	Second Rinse Distribute	0:00, 1:00*	0:00	D	Off	Off	C	Open
	Second Rinse Spin	4:35, 0:00*	0:00	RS	Off	Off	C	Open

(continued)



	WARNING
<p><b>To reduce the risk of electric shock, fire, explosion, serious injury or death:</b></p> <ul style="list-style-type: none"> <li><b>Disconnect electric power to the washer before servicing.</b></li> <li><b>Never start the washer with any guards/panels removed.</b></li> <li><b>Whenever ground wires are removed during servicing, these ground wires must be reconnected to ensure that the washer is properly grounded.</b></li> <li><b>Motor not grounded! Disconnect electric power before servicing motor.</b></li> </ul>	
W485	

(continued)

Stage	Step	Time	Default Time	Speed	Dispensers	Water Valves	Pump	Gravity Drain
THIRD RINSE 1 (optional)	Third Rinse 1 Fill/Agitate	3:25	0:00	RA	Det/Bl	TC	Off	Closed
	Third Rinse 1 Distribute	0:00, 1:00*	0:00	D	Off	Off	C	Open
	Third Rinse 1 Spin	4:35, 0:00*	0:00	RS	Off	Off	C	Open
THIRD RINSE 2 (optional)	Third Rinse 2 Fill/Agitate	3:25	0:00	RA	Det/Bl	TC	Off	Closed
	Third Rinse 2 Distribute	0:00, 1:00*	0:00	D	Off	Off	C	Open
	Third Rinse 2 Spin	4:35, 0:00*	0:00	RS	Off	Off	C	Open
FINAL RINSE	Final Fill/Agitate	3:25	3:25	RA	Det/Bl, Soft, ES2	TC	Off	Closed
	Final Distribute	0:00, 1:00*	0:00	D	Off	Off	C	Open
	Final Rinse Spin	0:00	0:00	RS	Off	Off	C	Open
FINAL SPIN	Final High Spin	9:00, 0:00*	9:00	LS*	Off	Off	C	Open
	Breakaway	2:20	2:20	BA	Off	Off	C	Open

Default Total Cycle Time: 42:00

Cycle Sequence Charts

	WARNING
<p><b>To reduce the risk of electric shock, fire, explosion, serious injury or death:</b></p> <ul style="list-style-type: none"> <li>• <b>Disconnect electric power to the washer before servicing.</b></li> <li>• <b>Never start the washer with any guards/panels removed.</b></li> <li>• <b>Whenever ground wires are removed during servicing, these ground wires must be reconnected to ensure that the washer is properly grounded.</b></li> <li>• <b>Motor not grounded! Disconnect electric power before servicing motor.</b></li> </ul>	
W485	

**Whites Wash Cycle**

Stage	Step	Time	Default Time	Speed	Dispensers	Water Valves	Pump	Gravity Drain
INITIAL DRAIN	Drain	0:10	0:10	Off	Off	Off	C	Open
WETTING	Fill/Agitate	2:30	2:30	WA	Det/Bl, ES1	H*	Off	Closed
SOAK (optional)	Soak Fill/Agitate	3:00	0:00	LA, Off	Off	H*	Off	Closed
	Soak Soak	30:00	0:00	SA, Off	Off	H*	Off	Closed
	Soak Distribute/Pump	1:00	0:00	D	Off	Off	C	Open
PRE-WASH (optional)	Prewash Fill/Agitate	6:00	0:00	RA	Off	H*	Off	Closed
	Prewash Distribute/Pump	1:00	0:00	D	Off	Off	C	Open
HEAT (heater models only)	Heat Fill/Agitate	2:00	0:00	RA	Det/Bl, ES1	H*	Off	Closed
	Heat Heater	28:00	0:00	RA	Off	H*	Off	Closed
WASH	Wash Fill/Agitate	15:00, 20:00, 25:00, 30:00	20:00	RA	Det/Bl, ES1	H*	Off	Closed
	Wash Distribute	0:00, 1:00*	0:00	D	Off	Off	C	Open
	Wash Spin	4:35, 0:00*	4:35	RS	Off	Off	C	Open

(continued)

	WARNING
<p><b>To reduce the risk of electric shock, fire, explosion, serious injury or death:</b></p> <ul style="list-style-type: none"> <li><b>Disconnect electric power to the washer before servicing.</b></li> <li><b>Never start the washer with any guards/panels removed.</b></li> <li><b>Whenever ground wires are removed during servicing, these ground wires must be reconnected to ensure that the washer is properly grounded.</b></li> <li><b>Motor not grounded! Disconnect electric power before servicing motor.</b></li> </ul>	
W485	

(continued)

Stage	Step	Time	Default Time	Speed	Dispensers	Water Valves	Pump	Gravity Drain
RINSE	Rinse Fill/Agitate	3:25	3:25	RA	Det/Bl	TC	Off	Closed
	Rinse Distribute	0:00, 1:00*	0:00	D	Off	Off	C	Open
	Rinse Spin	4:35, 0:00*	4:35	RS	Off	Off	C	Open
SECOND RINSE (optional)	Second Rinse Fill/Agitate	3:25	0:00	RA	Det/Bl	TC	Off	Closed
	Second Rinse Distribute	0:00, 1:00*	0:00	D	Off	Off	C	Open
	Second Rinse Spin	4:35, 0:00*	0:00	RS	Off	Off	C	Open
THIRD RINSE 1 (optional)	Third Rinse 1 Fill/Agitate	3:25	0:00	RA	Det/Bl	TC	Off	Closed
	Third Rinse 1 Distribute	0:00, 1:00*	0:00	D	Off	Off	C	Open
	Third Rinse 1 Spin	4:35, 0:00*	0:00	RS	Off	Off	C	Open
THIRD RINSE 2 (optional)	Third Rinse 2 Fill/Agitate	3:25	0:00	RA	Det/Bl	TC	Off	Closed
	Third Rinse 2 Distribute	0:00, 1:00*	0:00	D	Off	Off	C	Open
	Third Rinse 2 Spin	4:35, 0:00*	0:00	RS	Off	Off	C	Open

(continued)

## Cycle Sequence Charts

	WARNING
<p>To reduce the risk of electric shock, fire, explosion, serious injury or death:</p> <ul style="list-style-type: none"> <li>Disconnect electric power to the washer before servicing.</li> <li>Never start the washer with any guards/panels removed.</li> <li>Whenever ground wires are removed during servicing, these ground wires must be reconnected to ensure that the washer is properly grounded.</li> <li>Motor not grounded! Disconnect electric power before servicing motor.</li> </ul>	
W485	

(continued)

Stage	Step	Time	Default Time	Speed	Dispensers	Water Valves	Pump	Gravity Drain
FINAL RINSE	Final Fill/Agitate	3:25	3:25	RA	Det/Bl, Soft, ES2	TC	Off	Closed
	Final Distribute	0:00, 1:00*	0:00	D	Off	Off	C	Open
	Final Rinse Spin	0:00	0:00	RS	Off	Off	C	Open
FINAL SPIN	Final High Spin	9:00, 0:00*	9:00	HS*	Off	Off	C	Open
	Breakaway	2:20	2:20	BA	Off	Off	C	Open

Default Total Cycle Time: 50:00

## Delicate Wash Cycle

Stage	Step	Time	Default Time	Speed	Dispensers	Water Valves	Pump	Gravity Drain
INITIAL DRAIN	Drain	0:10	0:10	Off	Off	Off	C	Open
WETTING	Fill/Agitate	2:30	2:30	WA	Det/Bl, ES1	C*	Off	Closed
SOAK (optional)	Soak Fill/Agitate	3:00	0:00	LA, Off	Off	C*	Off	Closed
	Soak Soak	30:00	0:00	SA, Off	Off	C*	Off	Closed
	Soak Distribute/Pump	1:00	0:00	D	Off	Off	C	Open
PRE-WASH (optional)	Prewash Fill/Agitate	6:00	0:00	HA	Off	C*	Off	Closed
	Prewash Distribute/Pump	1:00	0:00	D	Off	Off	C	Open

(continued)

	WARNING
<p><b>To reduce the risk of electric shock, fire, explosion, serious injury or death:</b></p> <ul style="list-style-type: none"> <li>• <b>Disconnect electric power to the washer before servicing.</b></li> <li>• <b>Never start the washer with any guards/panels removed.</b></li> <li>• <b>Whenever ground wires are removed during servicing, these ground wires must be reconnected to ensure that the washer is properly grounded.</b></li> <li>• <b>Motor not grounded! Disconnect electric power before servicing motor.</b></li> </ul>	
W485	

(continued)

Stage	Step	Time	Default Time	Speed	Dispensers	Water Valves	Pump	Gravity Drain
HEAT (heater models only)	Heat Fill/Agitate	2:00	0:00	HA	Det/Bl, ES1	C*	Off	Closed
	Heat Heater	28:00	0:00	HA	Off	C*	Off	Closed
WASH	Wash Fill/Agitate	3:00, 7:00, 11:00, 15:00	7:00	HA	Det/Bl, ES1	C*	Off	Closed
	Wash Distribute	1:00	1:00	D	Off	Off	C	Open
	Wash Spin	0:00	0:00	Off	Off	Off	C	Open
RINSE	Rinse Fill/Agitate	3:25	3:25	HA	Det/Bl	TC	Off	Closed
	Rinse Distribute	1:00	1:00	D	Off	Off	C	Open
	Rinse Spin	0:00	0:00	Off	Off	Off	C	Open
SECOND RINSE (optional)	Second Rinse Fill/Agitate	3:25	0:00	HA	Det/Bl	TC	Off	Closed
	Second Rinse Distribute	1:00	0:00	D	Off	Off	C	Open
	Second Rinse Spin	0:00	0:00	Off	Off	Off	C	Open

(continued)

Cycle Sequence Charts

	WARNING
<p><b>To reduce the risk of electric shock, fire, explosion, serious injury or death:</b></p> <ul style="list-style-type: none"> <li>• <b>Disconnect electric power to the washer before servicing.</b></li> <li>• <b>Never start the washer with any guards/panels removed.</b></li> <li>• <b>Whenever ground wires are removed during servicing, these ground wires must be reconnected to ensure that the washer is properly grounded.</b></li> <li>• <b>Motor not grounded! Disconnect electric power before servicing motor.</b></li> </ul>	
W485	

(continued)

Stage	Step	Time	Default Time	Speed	Dispensers	Water Valves	Pump	Gravity Drain
THIRD RINSE 1 (optional)	Third Rinse 1 Fill/Agitate	3:25	0:00	HA	Det/Bl	TC	Off	Closed
	Third Rinse 1 Distribute	1:00	0:00	D	Off	Off	C	Open
	Third Rinse Spin	0:00	0:00	PS	Off	Off	C	Open
THIRD RINSE 2 (optional)	Third Rinse 2 Fill/Agitate	3:25	0:00	HA	Det/Bl	TC	Off	Closed
	Third Rinse 2 Distribute	1:00	0:00	D	Off	Off	C	Open
	Third Rinse 2 Spin	0:00	0:00	PS	Off	Off	C	Open
FINAL RINSE	Final Fill/Agitate	3:25	3:25	HA	Det/Bl, Soft, ES2	TC	Off	Closed
	Final Distribute	0:00, 1:00*	0:00	D	Off	Off	C	Open
	Final Rinse Spin	0:00	0:00	PS	Off	Off	C	Open
FINAL SPIN	Final High Spin	7:00, 0:00*	7:00	LS*	Off	Off	C	Open
	Breakaway	1:30	1:30	BA	Off	Off	C	Open

Default Total Cycle Time: 27:00

	WARNING
<p><b>To reduce the risk of electric shock, fire, explosion, serious injury or death:</b></p> <ul style="list-style-type: none"> <li>• <b>Disconnect electric power to the washer before servicing.</b></li> <li>• <b>Never start the washer with any guards/panels removed.</b></li> <li>• <b>Whenever ground wires are removed during servicing, these ground wires must be reconnected to ensure that the washer is properly grounded.</b></li> <li>• <b>Motor not grounded! Disconnect electric power before servicing motor.</b></li> </ul>	
W485	

**Quick Wash Cycle**

Stage	Step	Time	Default Time	Speed	Dispensers	Water Valves	Pump	Gravity Drain
INITIAL DRAIN	Drain	0:10	0:10	Off	Off	Off	C	Open
WETTING	Fill/Agitate	2:30	2:30	WA	Det/Bl, ES1	H, W, C, TC	Off	Closed
SOAK (optional)	Soak Fill/Agitate	3:00	0:00	LA, Off	Off	H, W, C, TC	Off	Closed
	Soak Soak	30:00	0:00	SA, Off	Off	H, W, C, TC	Off	Closed
	Soak Distribute/Pump	1:00	0:00	D	Off	Off	C	Open
PRE-WASH (optional)	Prewash Fill/Agitate	6:00	0:00	RA	Off	H, W, C, TC	Off	Closed
	Prewash Distribute/Pump	1:00	0:00	D	Off	Off	C	Open
HEAT (heater models only)	Heat Fill/Agitate	2:00	0:00	RA	Det/Bl, ES1	H, W, C, TC	Off	Closed
	Heat Heater	28:00	0:00	RA	Off	H, W, C, TC	Off	Closed
WASH	Wash Fill/Agitate	2:00, 4:00, 6:00, 8:00	4:00	RA	Det/Bl, ES1	H, W, C, TC	Off	Closed
	Wash Distribute	0:00, 1:00*	0:00	D	Off	Off	C	Open
	Wash Spin	4:35, 0:00*	4:35	RS	Off	Off	C	Open

(continued)

Cycle Sequence Charts

	WARNING
<p>To reduce the risk of electric shock, fire, explosion, serious injury or death:</p> <ul style="list-style-type: none"> <li>• Disconnect electric power to the washer before servicing.</li> <li>• Never start the washer with any guards/panels removed.</li> <li>• Whenever ground wires are removed during servicing, these ground wires must be reconnected to ensure that the washer is properly grounded.</li> <li>• Motor not grounded! Disconnect electric power before servicing motor.</li> </ul>	
W485	

(continued)

Stage	Step	Time	Default Time	Speed	Dispensers	Water Valves	Pump	Gravity Drain
RINSE	Rinse Fill/Agitate	3:25	0:00	RA	Det/Bl	TC	Off	Closed
	Rinse Distribute	0:00, 1:00*	0:00	D	Off	Off	C	Open
	Rinse Spin	4:35, 0:00*	0:00	RS	Off	Off	C	Open
SECOND RINSE (optional)	Second Rinse Fill/Agitate	3:25	0:00	RA	Det/Bl	TC	Off	Closed
	Second Rinse Distribute	0:00, 1:00*	0:00	D	Off	Off	C	Open
	Second Rinse Spin	4:35, 0:00*	0:00	RS	Off	Off	C	Open
THIRD RINSE 1 (optional)	Third Rinse 1 Fill/Agitate	3:25	0:00	RA	Det/Bl	TC	Off	Closed
	Third Rinse 1 Distribute	0:00, 1:00*	0:00	D	Off	Off	C	Open
	Third Rinse 1 Spin	4:35, 0:00*	0:00	RS	Off	Off	C	Open

(continued)



	WARNING
<p>To reduce the risk of electric shock, fire, explosion, serious injury or death:</p> <ul style="list-style-type: none"> <li>• Disconnect electric power to the washer before servicing.</li> <li>• Never start the washer with any guards/panels removed.</li> <li>• Whenever ground wires are removed during servicing, these ground wires must be reconnected to ensure that the washer is properly grounded.</li> <li>• Motor not grounded! Disconnect electric power before servicing motor.</li> </ul>	
W485	

(continued)

Stage	Step	Time	Default Time	Speed	Dispensers	Water Valves	Pump	Gravity Drain
THIRD RINSE 2 (optional)	Third Rinse 2 Fill/Agitate	3:25	0:00	RA	Det/Bl	TC	Off	Closed
	Third Rinse 2 Distribute	0:00, 1:00*	0:00	D	Off	Off	C	Open
	Third Rinse 2 Spin	4:35, 0:00*	0:00	RS	Off	Off	C	Open
FINAL RINSE	Final Fill/Agitate	3:25	3:25	RA	Det/Bl, Soft, ES2	TC	Off	Closed
	Final Distribute	0:00, 1:00*	0:00	D	Off	Off	C	Open
	Final Rinse Spin	0:00	0:00	RS	Off	Off	C	Open
FINAL SPIN	Final High Spin	9:00, 0:00*	9:00	HS*	Off	Off	C	Open
	Breakaway	2:20	2:20	BA	Off	Off	C	Open

Default Total Cycle Time: 26:00

Cycle Sequence Charts

	WARNING
<p>To reduce the risk of electric shock, fire, explosion, serious injury or death:</p> <ul style="list-style-type: none"> <li>• Disconnect electric power to the washer before servicing.</li> <li>• Never start the washer with any guards/panels removed.</li> <li>• Whenever ground wires are removed during servicing, these ground wires must be reconnected to ensure that the washer is properly grounded.</li> <li>• Motor not grounded! Disconnect electric power before servicing motor.</li> </ul>	
W485	

**Heavy Duty Wash Cycle**

Stage	Step	Time	Default Time	Speed	Dispensers	Water Valves	Pump	Gravity Drain
INITIAL DRAIN	Drain	0:10	0:10	Off	Off	Off	C	Open
WETTING	Fill/Agitate	2:30	2:30	WA	Det/BI, ES1	H, W, C, TC	Off	Closed
SOAK (optional)	Soak Fill/Agitate	3:00	0:00	LA, Off	Off	H, W, C, TC	Off	Closed
	Soak Soak	30:00	0:00	SA, Off	Off	H, W, C, TC	Off	Closed
	Soak Distribute/Pump	1:00	0:00	D	Off	Off	C	Open
PRE-WASH (optional)	Prewash Fill/Agitate	6:00	0:00	RA	Off	H, W, C, TC	Off	Closed
	Prewash Distribute/Pump	1:00	0:00	D	Off	Off	C	Open
HEAT (heater models only)	Heat Fill/Agitate	2:00	0:00	RA	Det/BI, ES1	H, W, C, TC	Off	Closed
	Heat Heater	28:00	0:00	RA	Off	H, W, C, TC	Off	Closed
WASH	Wash Fill/Agitate	10:00, 15:00, 20:00, 25:00	15:00	RA	Det/BI, ES1	H, W, C, TC	Off	Closed
	Wash Distribute	0:00, 1:00*	0:00	D	Off	Off	C	Open
	Wash Spin	4:35, 0:00*	4:35	RS	Off	Off	C	Open

(continued)

	WARNING
<p><b>To reduce the risk of electric shock, fire, explosion, serious injury or death:</b></p> <ul style="list-style-type: none"> <li>• <b>Disconnect electric power to the washer before servicing.</b></li> <li>• <b>Never start the washer with any guards/panels removed.</b></li> <li>• <b>Whenever ground wires are removed during servicing, these ground wires must be reconnected to ensure that the washer is properly grounded.</b></li> <li>• <b>Motor not grounded! Disconnect electric power before servicing motor.</b></li> </ul>	
W485	

(continued)

Stage	Step	Time	Default Time	Speed	Dispensers	Water Valves	Pump	Gravity Drain
RINSE	Rinse Fill/Agitate	3:25	3:25	RA	Det/Bl	TC	Off	Closed
	Rinse Distribute	0:00, 1:00*	0:00	D	Off	Off	C	Open
	Rinse Spin	4:35, 0:00*	4:35	RS	Off	Off	C	Open
SECOND RINSE (optional)	Second Rinse Fill/Agitate	3:25	0:00	RA	Det/Bl	TC	Off	Closed
	Second Rinse Distribute	0:00, 1:00*	0:00	D	Off	Off	C	Open
	Second Rinse Spin	4:35, 0:00*	0:00	RS	Off	Off	C	Open
THIRD RINSE 1 (optional)	Third Rinse 1 Fill/Agitate	3:25	0:00	RA	Det/Bl	TC	Off	Closed
	Third Rinse 1 Distribute	0:00, 1:00*	0:00	D	Off	Off	C	Open
	Third Rinse 1 Spin	4:35, 0:00*	0:00	RS	Off	Off	C	Open
THIRD RINSE 2 (optional)	Third Rinse 2 Fill/Agitate	3:25	0:00	RA	Det/Bl	TC	Off	Closed
	Third Rinse 2 Distribute	0:00, 1:00*	0:00	D	Off	Off	C	Open
	Third Rinse 2 Spin	4:35, 0:00*	0:00	RS	Off	Off	C	Open

(continued)

Cycle Sequence Charts

	WARNING
<p>To reduce the risk of electric shock, fire, explosion, serious injury or death:</p> <ul style="list-style-type: none"> <li>• Disconnect electric power to the washer before servicing.</li> <li>• Never start the washer with any guards/panels removed.</li> <li>• Whenever ground wires are removed during servicing, these ground wires must be reconnected to ensure that the washer is properly grounded.</li> <li>• Motor not grounded! Disconnect electric power before servicing motor.</li> </ul>	
W485	

(continued)

Stage	Step	Time	Default Time	Speed	Dispensers	Water Valves	Pump	Gravity Drain
FINAL RINSE	Final Fill/Agitate	3:25	3:25	RA	Det/Bl, Soft, ES2	TC	Off	Closed
	Final Distribute	0:00, 1:00*	0:00	D	Off	Off	C	Open
	Final Rinse Spin	0:00	0:00	RS	Off	Off	C	Open
FINAL SPIN	Final High Spin	9:00, 0:00*	9:00	HS*	Off	Off	C	Open
	Breakaway	2:20	2:20	BA	Off	Off	C	Open

Default Total Cycle Time: 45:00

	WARNING
<p><b>To reduce the risk of electric shock, fire, explosion, serious injury or death:</b></p> <ul style="list-style-type: none"> <li>• <b>Disconnect electric power to the washer before servicing.</b></li> <li>• <b>Never start the washer with any guards/panels removed.</b></li> <li>• <b>Whenever ground wires are removed during servicing, these ground wires must be reconnected to ensure that the washer is properly grounded.</b></li> <li>• <b>Motor not grounded! Disconnect electric power before servicing motor.</b></li> </ul>	
W485	

**Bulky Wash Cycle**

Stage	Step	Time	Default Time	Speed	Dispensers	Water Valves	Pump	Gravity Drain
INITIAL DRAIN	Drain	0:10	0:10	Off	Off	Off	C	Open
WETTING	Fill/Agitate	2:30	2:30	WA	Det/Bl, ES1	H, W, C, TC	Off	Closed
SOAK (optional)	Soak Fill/Agitate	3:00	0:00	LA, Off	Off	H, W, C, TC	Off	Closed
	Soak Soak	30:00	0:00	SA, Off	Off	H, W, C, TC	Off	Closed
	Soak Distribute/Pump	1:00	0:00	D	Off	Off	C	Open
PRE-WASH (optional)	Prewash Fill/Agitate	6:00	0:00	RA	Off	H, W, C, TC	Off	Closed
	Prewash Distribute/Pump	1:00	0:00	D	Off	Off	C	Open
HEAT (heater models only)	Heat Fill/Agitate	2:00	0:00	RA	Det/Bl, ES1	H, W, C, TC	Off	Closed
	Heat Heater	28:00	0:00	RA	Off	H, W, C, TC	Off	Closed
WASH	Wash Fill/Agitate	7:00, 11:00, 15:00, 19:00	11:00	RA	Det/Bl, ES1	H, W, C, TC	Off	Closed
	Wash Distribute	0:00, 1:00*	0:00	D	Off	Off	C	Open
	Wash Spin	4:35, 0:00*	4:35	RS	Off	Off	C	Open

(continued)

Cycle Sequence Charts

	WARNING
<p><b>To reduce the risk of electric shock, fire, explosion, serious injury or death:</b></p> <ul style="list-style-type: none"> <li>• <b>Disconnect electric power to the washer before servicing.</b></li> <li>• <b>Never start the washer with any guards/panels removed.</b></li> <li>• <b>Whenever ground wires are removed during servicing, these ground wires must be reconnected to ensure that the washer is properly grounded.</b></li> <li>• <b>Motor not grounded! Disconnect electric power before servicing motor.</b></li> </ul>	
W485	

(continued)

Stage	Step	Time	Default Time	Speed	Dispensers	Water Valves	Pump	Gravity Drain
RINSE	Rinse Fill/Agitate	3:25	3:25	RA	Det/Bl	TC	Off	Closed
	Rinse Distribute	0:00, 1:00*	0:00	D	Off	Off	C	Open
	Rinse Spin	4:35, 0:00*	4:35	RS	Off	Off	C	Open
SECOND RINSE (optional)	Second Rinse Fill/Agitate	3:25	0:00	RA	Det/Bl	TC	Off	Closed
	Second Rinse Distribute	0:00, 1:00*	0:00	D	Off	Off	C	Open
	Second Rinse Spin	4:35, 0:00*	0:00	RS	Off	Off	C	Open
THIRD RINSE 1 (optional)	Third Rinse 1 Fill/Agitate	3:25	0:00	RA	Det/Bl	TC	Off	Closed
	Third Rinse 1 Distribute	0:00, 1:00*	0:00	D	Off	Off	C	Open
	Third Rinse 1 Spin	4:35, 0:00*	0:00	RS	Off	Off	C	Open
THIRD RINSE 2 (optional)	Third Rinse 2 Fill/Agitate	3:25	0:00	RA	Det/Bl	TC	Off	Closed
	Third Rinse 2 Distribute	0:00, 1:00*	0:00	D	Off	Off	C	Open
	Third Rinse 2 Spin	4:35, 0:00*	0:00	RS	Off	Off	C	Open

(continued)

	WARNING
<p>To reduce the risk of electric shock, fire, explosion, serious injury or death:</p> <ul style="list-style-type: none"> <li>• Disconnect electric power to the washer before servicing.</li> <li>• Never start the washer with any guards/panels removed.</li> <li>• Whenever ground wires are removed during servicing, these ground wires must be reconnected to ensure that the washer is properly grounded.</li> <li>• Motor not grounded! Disconnect electric power before servicing motor.</li> </ul>	
W485	

(continued)

Stage	Step	Time	Default Time	Speed	Dispensers	Water Valves	Pump	Gravity Drain
FINAL RINSE	Final Fill/Agitate	3:25	3:25	RA	Det/Bl, Soft, ES2	TC	Off	Closed
	Final Distribute	0:00, 1:00*	0:00	D	Off	Off	C	Open
	Final Rinse Spin	0:00	0:00	RS	Off	Off	C	Open
FINAL SPIN	Final High Spin	8:00, 0:00*	8:00	MS*	Off	Off	C	Open
	Breakaway	2:20	2:20	BA	Off	Off	C	Open

Default Total Cycle Time: 40:00

### Rinse and Spin Cycle

Stage	Step	Time	Default Time	Speed	Dispensers	Water Valves	Pump	Gravity Drain
INITIAL DRAIN	Drain	0:10	0:10	Off	Off	Off	C	Open
SOAK (optional)	Soak Fill/Agitate	3:00	0:00	LA, Off	Off	H, W, C, TC	Off	Closed
	Soak Soak	30:00	0:00	SA, Off	Off	H, W, C, TC	Off	Closed
	Soak Distribute/Pump	1:00	0:00	D	Off	Off	C	Open
PRE-WASH (optional)	Prewash Fill/Agitate	6:00	0:00	RA	Off	H, W, C, TC	Off	Closed
	Prewash Distribute/Pump	1:00	0:00	D	Off	Off	C	Open

(continued)

Cycle Sequence Charts

	WARNING
<p><b>To reduce the risk of electric shock, fire, explosion, serious injury or death:</b></p> <ul style="list-style-type: none"> <li>• <b>Disconnect electric power to the washer before servicing.</b></li> <li>• <b>Never start the washer with any guards/panels removed.</b></li> <li>• <b>Whenever ground wires are removed during servicing, these ground wires must be reconnected to ensure that the washer is properly grounded.</b></li> <li>• <b>Motor not grounded! Disconnect electric power before servicing motor.</b></li> </ul>	
W485	

(continued)

Stage	Step	Time	Default Time	Speed	Dispensers	Water Valves	Pump	Gravity Drain
SECOND RINSE (optional)	Second Rinse Fill/Agitate	3:25	0:00	RA	Det/Bl	TC	Off	Closed
	Second Rinse Distribute	0:00, 1:00*	0:00	D	Off	Off	C	Open
	Second Rinse Spin	4:35, 0:00*	0:00	RS	Off	Off	C	Open
THIRD RINSE 1 (optional)	Third Rinse 1 Fill/Agitate	3:25	0:00	RA	Det/Bl	TC	Off	Closed
	Third Rinse 1 Distribute	0:00, 1:00*	0:00	D	Off	Off	C	Open
	Third Rinse 1 Spin	4:35, 0:00*	0:00	RS	Off	Off	C	Open
THIRD RINSE 2 (optional)	Third Rinse 2 Fill/Agitate	3:25	0:00	RA	Det/Bl	TC	Off	Closed
	Third Rinse 2 Distribute	0:00, 1:00*	0:00	D	Off	Off	C	Open
	Third Rinse 2 Spin	4:35, 0:00*	0:00	RS	Off	Off	C	Open

(continued)



	WARNING
<p><b>To reduce the risk of electric shock, fire, explosion, serious injury or death:</b></p> <ul style="list-style-type: none"> <li><b>Disconnect electric power to the washer before servicing.</b></li> <li><b>Never start the washer with any guards/panels removed.</b></li> <li><b>Whenever ground wires are removed during servicing, these ground wires must be reconnected to ensure that the washer is properly grounded.</b></li> <li><b>Motor not grounded! Disconnect electric power before servicing motor.</b></li> </ul>	
W485	

(continued)

Stage	Step	Time	Default Time	Speed	Dispensers	Water Valves	Pump	Gravity Drain
FINAL RINSE	Final Fill/Agitate	3:25	3:25	RA	Det/Bl, Soft, ES2	TC	Off	Closed
	Final Distribute	0:00, 1:00*	0:00	D	Off	Off	C	Open
	Final Rinse Spin	0:00	0:00	RS	Off	Off	C	Open
FINAL SPIN	Final High Spin	9:00, 0:00*	9:00	HS*	Off	Off	C	Open
	Breakaway	2:25	2:25	BA	Off	Off	C	Open

Default Total Cycle Time: 15:00

### Spin Only Cycle

Stage	Step	Time	Default Time	Speed	Dispensers	Water Valves	Pump	Gravity Drain
INITIAL DRAIN	Drain	0:10	0:10	Off	Off	Off	C	Open
SOAK (optional)	Soak Fill/Agitate	3:00	0:00	LA, Off	Off	H, W, C, TC	Off	Closed
	Soak Soak	30:00	0:00	SA, Off	Off	H, W, C, TC	Off	Closed
	Soak Distribute/Pump	1:00	0:00	D	Off	Off	C	Open
PRE-WASH (optional)	Prewash Fill/Agitate	6:00	0:00	RA	Off	H, W, C, TC	Off	Closed
	Prewash Distribute/Pump	1:00	0:00	D	Off	Off	C	Open

(continued)

Cycle Sequence Charts

	WARNING
<p><b>To reduce the risk of electric shock, fire, explosion, serious injury or death:</b></p> <ul style="list-style-type: none"> <li><b>Disconnect electric power to the washer before servicing.</b></li> <li><b>Never start the washer with any guards/panels removed.</b></li> <li><b>Whenever ground wires are removed during servicing, these ground wires must be reconnected to ensure that the washer is properly grounded.</b></li> <li><b>Motor not grounded! Disconnect electric power before servicing motor.</b></li> </ul>	
W485	

(continued)

Stage	Step	Time	Default Time	Speed	Dispensers	Water Valves	Pump	Gravity Drain
SECOND RINSE (optional)	Second Rinse Fill/Agitate	3:25	0:00	RA	Det/Bl	TC	Off	Closed
	Second Rinse Distribute	0:00, 1:00*	0:00	D	Off	Off	C	Open
	Second Rinse Spin	4:35, 0:00*	0:00	RS	Off	Off	C	Open
THIRD RINSE 1 (optional)	Third Rinse 1 Fill/Agitate	3:25	0:00	RA	Det/Bl	TC	Off	Closed
	Third Rinse 1 Distribute	0:00, 1:00*	0:00	D	Off	Off	C	Open
	Third Rinse 1 Spin	4:35, 0:00*	0:00	RS	Off	Off	C	Open
THIRD RINSE 2 (optional)	Third Rinse 2 Fill/Agitate	3:25	0:00	RA	Det/Bl	TC	Off	Closed
	Third Rinse 2 Distribute	0:00, 1:00*	0:00	D	Off	Off	C	Open
	Third Rinse 2 Spin	4:35, 0:00*	0:00	RS	Off	Off	C	Open
FINAL SPIN	Final High Spin	9:00, 0:00*	9:00	HS*	Off	Off	C	Open
	Breakaway	1:50	1:50	BA	Off	Off	C	Open

Default Total Cycle Time: 11:00

	WARNING
<p><b>To reduce the risk of electric shock, fire, explosion, serious injury or death:</b></p> <ul style="list-style-type: none"> <li>• <b>Disconnect electric power to the washer before servicing.</b></li> <li>• <b>Never start the washer with any guards/panels removed.</b></li> <li>• <b>Whenever ground wires are removed during servicing, these ground wires must be reconnected to ensure that the washer is properly grounded.</b></li> <li>• <b>Motor not grounded! Disconnect electric power before servicing motor.</b></li> </ul>	
W485	

**Keys:**

**Motor Speeds**

SYMBOL	SPEED
WA	Wetting Agitate
HA	Hand Wash Agitate
LA	Low Agitate
RA	Regular Agitate
SA	Soak Agitate
BA	Breakaway Agitate
D	Distribute
RS	Ramp Spin
NS	No Spin
LS	Low Spin
MS	Medium Spin
HS	High Spin

**Water Temperature**

SYMBOL	DEFINITION
H	Hot
W	Warm
C	Cool
TC	Cold (Tap)

**NOTE: Water temperature will not exceed that selected by the user for the wash fill step.**

**Dispensers**

SYMBOL	DEFINITION
Det/Bl	Detergent/Bleach Dispenser
Soft	Softener Dispenser
ES1	External Supply #1
ES2	External Supply #2
ES3	External Supply #3
ES4	External Supply #4

**Pump**

SYMBOL	DEFINITION
C	Continuous Pump
P	Pulsed Pump

**Gravity Drain**

SYMBOL	DEFINITION
Open	Drain is open to drain
Closed	Drain is closed

**External Supplies**

External supplies 1 and 2 will only come on once per cycle with ES1 turning on for the wash fill portion of the cycle. If the wetting step immediately precedes the wash step, then the ES1 will turn on in that step, or if the heat step immediately precedes the wash step, ES1 will turn on in that step. Otherwise ES1 will turn on in the wash step. ES2 will always turn on in the final rinse step.

