

# ON-PREMISES STACK TUMBLE DRYER

NTT  
RANGE

NTT30  
30lb



## FEATURES

- Easy-to-use digital control
- Double capacity within the same footprint
- Gas, electric and steam heating
- Large door opening for easy loading and unloading
- Galvanized cylinder
- Axial airflow
- Large lint filter
- Fits through 36" door opening

## OPTIONS

- Stainless steel cylinder
- Stainless steel front panel
- Sensodry+® over-dry prevention technology lowers energy, utility and linen replacement costs



DOUBLE CAPACITY



EASY OPERATION



LARGE DOOR OPENING



XQ Control



Dual Digital Control



*You have plans. We have solutions.*

1.844.275.2828 | [www.lavxel.com](http://www.lavxel.com)

MODEL		NTT30
CONTROL OPTION		XQ, DDC
CAPACITY - lb (kg)		2x30 (2x14)
OVERALL WIDTH - in (mm)		31.5 (800)
OVERALL DEPTH - in (mm)		42.76 (1086)
OVERALL HEIGHT - in (mm)		76.25 (1937)
CYLINDER DIAMETER - in (mm)		26.5 (673)
CYLINDER VOLUME - cu. ft (liters)		2x9.6 (2x272)
DOOR OPENING SIZE - in (mm)		22.63 (575)
ENERGY DATA	Steam Models - 100 psi	111,000 Btu/h
	Electric Models	21 kW
	Gas Models	2x73,000 Btu/h
EXHAUST - in (mm)		1x8
GAS CONNECTIONS - one manifold - in (npt)		0.5
STEAM CONNECTIONS - in (npt)		0.75
MOTOR - hp	Fan	2x0.25
	Drive	2x0.25
DRYING AVERAGE - lbs/min	Gas Heating	0.64
	Electric Heating	0.69
AIRFLOW - cfm		400
ELECTRIC SPECS - amps		Non Rev (both pockets)
GAS & STEAM	100/200-220/60/1 2W+G	22.0/11.6 total
	120/208-240/60/1 2W/3W+G	16.0/8.0 total
	200-208/240/60/3 3W+G	6.4/6.4 total
	380/60/3 3W+G	3.0 total
	440/60/3 3W+G	3.3 total
ELECTRIC	460-480/60/3 3W+G	3.3 total
	200-208/60/3 3W+G	62x2 - 124 total
	240/60/3 3W+G	54x2 - 108 total
	380/60/3 3W+G	33x2 - 66 total
SHIPPING DIMENSIONS - in (mm)	440/60/3 3W+G	29x2 - 56 total
	460-480/60/3 3W+G	27x2 - 54 total
	APPROX.	Width Depth Height
NET WEIGHT - lb (kg)		550 (249)
SHIPPING WEIGHT - lb (kg)		582 (264)
AGENCY APPROVALS		cCSAus

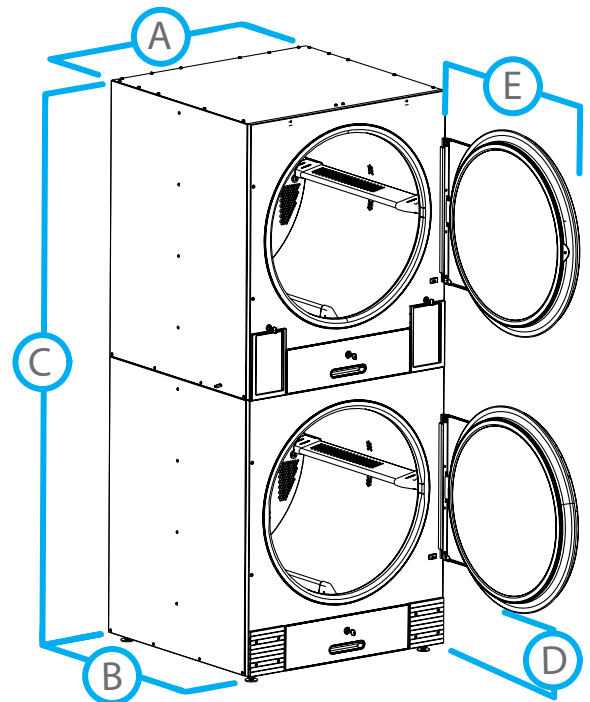

DIMENSIONS		NTT30
A.	OVERALL WIDTH - in (mm)	31.5 (800)
B.	OVERALL DEPTH - in (mm)	42.76 (1086)
C.	OVERALL HEIGHT - in (mm)	76.25 (1937)
D.	DOOR BOTTOM TO FLOOR - in (mm)	10.69 (272)
E.	DOOR SWING - in (mm)	28 (711)