

Commercial Dryers

Refer to Page 6 for Model Numbers

Troubleshooting

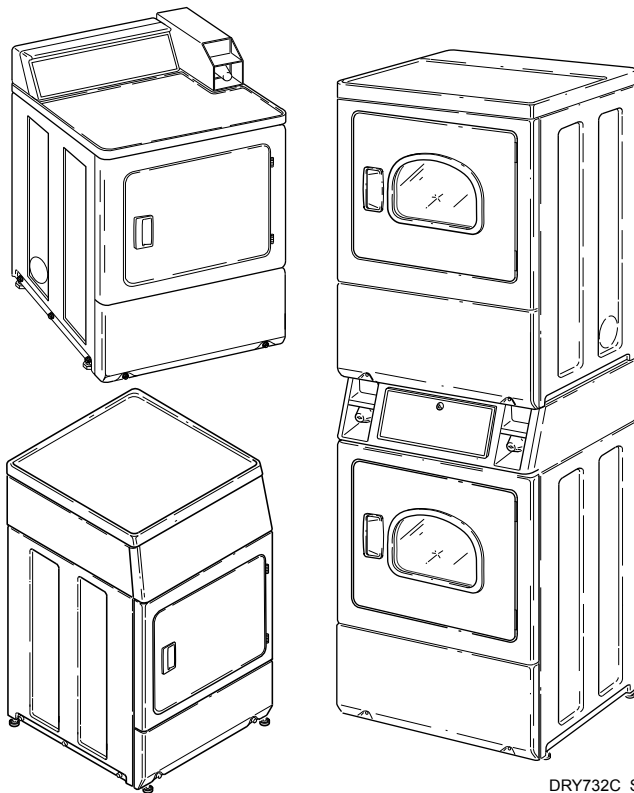

DRY732C_SVG

Table of Contents

Safety Information.....	5
Locating an Authorized Service Person.....	6
Introduction.....	7
Customer Service.....	7
Serial Plate Location.....	7
Model Identification.....	7
How Your Dryer Works.....	9
Operating Modes and Dipswitches.....	10
Coin Slide and Non-Metered Models.....	10
Setting Dry Time Dipswitches.....	10
Test Setting.....	12
Dryer Troubleshooting.....	13
Dryer Motor Does Not Run.....	14
Dryer Stops in Cycle; Quits After the First Few Loads; Has a Burning Smell; Cycles on Motor Thermal Protector.....	16
Dryer Motor Runs but Cylinder Does Not Turn.....	17
Dryer Motor Does Not Stop.....	19
Dryer Runs Only When Door is Open.....	20
Dryer Heating Assembly Does Not Heat or Burner Does Not Ignite.....	21
Igniter Does Not Glow (Gas Supply Sufficient) - Gas Dryer Models.....	23
Burner Ignites and Goes Out Repeatedly (Gas Dryer Models).....	24
Igniter Glows but Burner Does Not Ignite (Gas Dryer Models).....	25
Dryer Heater Assembly or Burner Shuts Off Prematurely.....	26
Dryer Heater Assembly or Burner Repeatedly Cycles Off On Limit Thermostat.....	27
Dryer Heater Assembly or Burner Does Not Shut Off.....	29
Clothes Do Not Dry in Dryer.....	30
Clothes Are Too Hot When Removed From Dryer.....	31
Excessive Chattering or Vibrating Noise in Dryer.....	32
Excessive Humming or Whistling Noise in Dryer.....	33
Coin Slide Control Troubleshooting.....	34
No Cycle Start When the Coin Slide is Activated.....	35
Gas Dryer - No Motor Run - Door Open Analysis.....	37
Gas Dryer - No Motor Run - Push Start Analysis.....	39
Gas Dryer - No Heat Analysis.....	41
Electric Dryer - No Motor Run - Door Open Analysis.....	43
Electric Dryer - No Motor Run - Push Start Analysis.....	45

Electric Dryer - No Heat Analysis.....	47
Adjustments.....	49
Leveling Legs.....	49
Burner Flame (Gas Models).....	49
Test Procedures.....	51
Fabric Selector Switch.....	51
Drive Motor.....	51
Drive Motor - Motor Switch.....	53
Drive Motor - Motor Windings.....	55
Motor Switch.....	55
Burner System Operation - Gas Models.....	57
Electrical Circuit To Ignition System (Gas Models).....	58
Gas Valve Coils Check (Gas Models).....	59
Sensor Check (Gas Models).....	59
Igniter Check - Gas Models.....	59
Ignition Control Grounding Check - Silicon Nitride Ignition.....	60
Thermal Fuse (Electric Models).....	60
Heater Assembly (Electric Models).....	60
Cycling or Limit Thermostat.....	60
Door Switch.....	60
Thermistor.....	61
Internal Wiring of Dryer Motor Switch.....	62

Safety Information

Precautionary statements (“DANGER,” “WARNING,” and “CAUTION”), followed by specific instructions, are found in this manual and on machine decals. These precautions are intended for the personal safety of the operator, user, servicer, and those maintaining the machine.

	DANGER
Indicates an imminently hazardous situation that, if not avoided, will cause severe personal injury or death.	

	WARNING
Indicates a hazardous situation that, if not avoided, could cause severe personal injury or death.	

	CAUTION
Indicates a hazardous situation that, if not avoided, may cause minor or moderate personal injury or property damage.	

Additional precautionary statements (“IMPORTANT” and “NOTE”) are followed by specific instructions.

IMPORTANT: The word “IMPORTANT” is used to inform the reader of specific procedures where minor machine damage will occur if the procedure is not followed.

NOTE: The word “NOTE” is used to communicate installation, operation, maintenance or servicing information that is important but not hazard related.

In the interest of safety, some general precautions relating to the operation of this machine follow.

	WARNING
<ul style="list-style-type: none"> • Failure to install, maintain and/or operate this product according to the manufacturer’s instructions may result in conditions which can produce serious injury, death and/or property damage. • Do not repair or replace any part of the product or attempt any servicing unless specifically recommended or published in this Service Manual and unless you understand and have the skills to carry out the servicing. • Whenever ground wires are removed during servicing, these ground wires must be reconnected to ensure that the product is properly grounded and to reduce the risk of fire, electric shock, serious injury or death. 	
W006R2	

	WARNING
<p>To reduce the risk of electric shock, fire, explosion, serious injury or death:</p> <ul style="list-style-type: none"> • Disconnect electric power to the dryer before servicing. • Close gas shut-of valve to gas dryer before servicing. • Never start the Dryer with any guards/panels removed. • Whenever ground wires are removed during servicing, these ground wires must be reconnected to ensure that the dryer is properly grounded. 	
W001R1	

	CAUTION
<p>If you or an unqualified person perform service on your product, you must assume the responsibility for any personal injury or property damage which may result. The manufacturer will not be responsible for any injury or property damage arising from improper service and/or service procedures.</p>	
W008	

NOTE: The WARNINGS and IMPORTANT INSTRUCTIONS appearing in this manual are not meant to cover all possible conditions and situations that may occur. Common sense, caution and care must be exercised when installing, maintaining or operating the machine.

Always contact your dealer, distributor, service agent or the manufacturer about any problems or conditions you do not understand.

Locating an Authorized Service Person

Alliance Laundry Systems is not responsible for personal injury or property damage resulting from improper service. Review all service information before beginning repairs.

Warranty service must be performed by an authorized technician, using authorized factory parts. If service is required after the warranty expires, Alliance Laundry Systems also recommends contacting an authorized technician and using authorized factory parts.

Introduction

Customer Service

If literature or replacement parts are required, contact the source from whom the machine was purchased or contact Alliance Laundry Systems at (920) 748-3950 for the name and address of the nearest authorized parts distributor.

For technical assistance, call (920) 748-3121.

Serial Plate Location

When calling or writing about your product, be sure to mention model and serial numbers. Model and serial numbers are located on Serial Plate as shown.

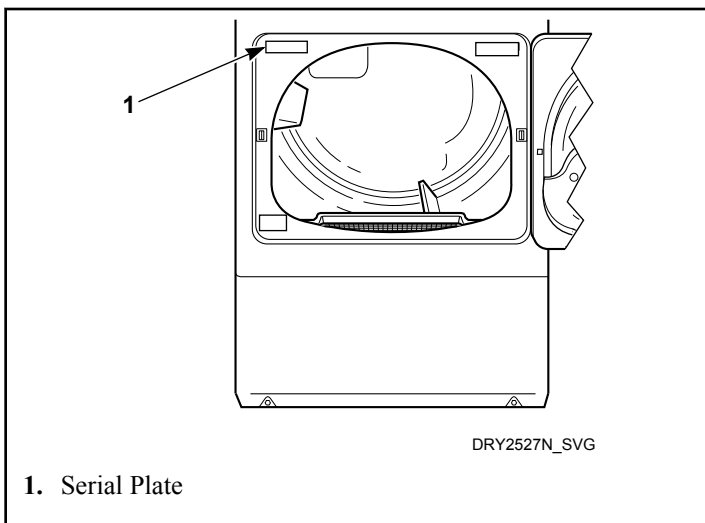

Figure 1

Model Identification

Information in this manual is applicable to these washer models:

BDEMNRGS173TW01	KDEMNRGS173TW01	PDESXRGS173TG02	SDGSXRGS113TQ01
BDEMNRGS433AW01	KDEMNRGS303BW33	PDESXRGS173TW02	SDGSXRGS113TW01
BDESXRGS173TW01	KDEMNRGS303UW01	PDGSXRGS113CG02	SDGSXRGS113TW02
BDGMNRGS113CW01	KDESXRGS173TW01	PDGSXRGS113CW02	SDGSXRGS303AW01
BDGMNRGS303AW01	KDESXRGS303UW01	PDGSXRGS113TG02	SDGSXRGS303EW01
BDGSXRGS113TW01	KDGMNRGS113TW01	PDGSXRGS113TW02	SSEMNRGS153TW01
BSESXAGS173TW01	KDGMNRGS303EW01	SDEMNRGS153TW01	SSEMNRGS173TW01
BSGSXAGS113TW01	KDGMNRGS303UW01	SDEMNRGS173CW01	SSEMNRGS303NW01
GDEMNRGS303UW01	KDGSXRGS113TW01	SDEMNRGS173TW01	SSEMNRGS303UW01
GDEMNRGS543NW01	KDGSXRGS303EW01	SDEMNRGS303WW01	SSEMNRGS433AW01
GDESCRGS303UW01	KSEMNRGS173TW01	SDEMNRGS303ZW01	SSESXAGS153TW01
GDESCRGS543ZW01	KSEMNRGS303BW33	SDEMNRGS433AW01	SSESXAGS173TW01
GDESXRGS303UW01	KSESXAGS173TW01	SDESXRGS153CW02	SSESXAGS303UW01
GDESXRGS543ZW01	KSGMNAGS113TW01	SDESXRGS153TW01	SSESXAGW173TW01
GDLSCRGS543ZW01	KSGSXAGS113TW01	SDESXRGS173CW02	SSESXAGW303NQ01
HDEMNRGS173CW01	NDEMNRGS303NW22	SDESXRGS173TQ01	SSESXAGW303NW01
HDESXRGS153CW01	NDEMNRGS303UW01	SDESXRGS173TW01	SSESXAGW433AW01
HDESXRGS173CW01	NDEMNRGS403UW01	SDESXRGS173TW02	SSGMNRGS113TW01
HDESXRGS173TQ01	NDEMNRGS543NW22	SDESXRGS303UW01	SSGSXAGS113TQ01
HDESXRGS173TW01	NDESXRGS303NW22	SDESXRGS303WW01	SSGSXAGS113TW01
HDESXRGS303UW01	NDESXRGS543NW22	SDESXRGS303ZQ01	SSGSXAGS303EW01
HDESXRGS403UW01	NDGMNRGS303NW22	SDESXRGS303ZW01	SSGSXAGW113TW01
HDGMNRGS113CW01	NDGMNRGS543NW22	SDESXRGS403UW01	SSGSXAGW303AW01
HDGSXRGS113CW01	NDGSXRGS303NW22	SDESXRGS433AW01	SSGSXAGW303BW01
HDGSXRGS113TQ01	NDGSXRGS543NW22	SDESXRGS543NW22	UDEMNRGS173CW01
HDGSXRGS113TW01	NSESXAGW303NW22	SDGMNRGS113CW01	UDGMNRGS113CW01
HSESXAGW173TW01	NSGSXAGW303NW22	SDGMNRGS113TW01	USEMNRGS173TW01
HSGSXAGW093CW01	PDESXRGS173CG02	SDGMNRGS303ZW01	USGMNRGS113TW01
HSGSXAGW113TW01	PDESXRGS173CW02	SDGSXRGS113CW02	

Table 1

How Your Dryer Works

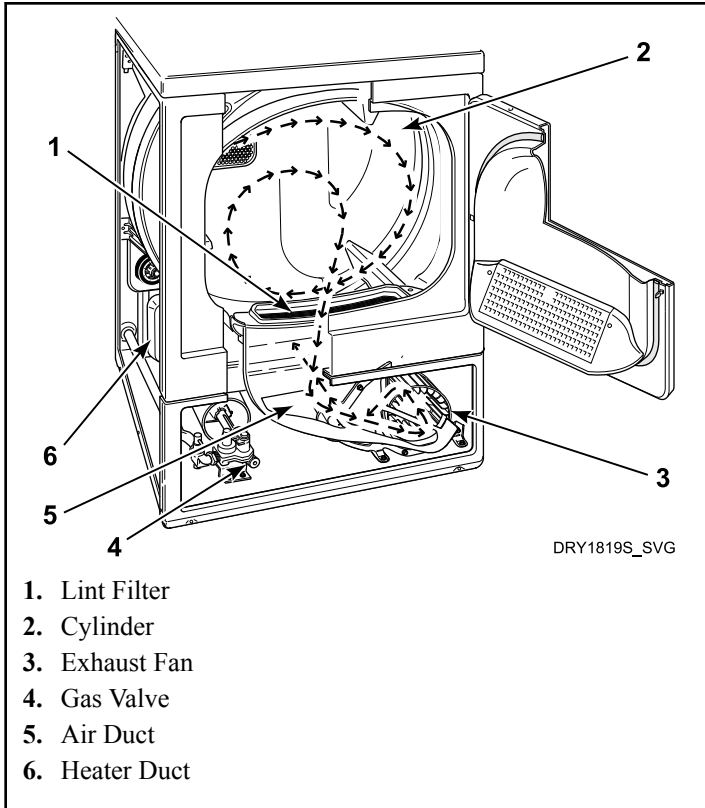

The dryer uses heated air to dry loads of laundry. When the motor is started, the exhaust fan pulls room temperature air in through louvers at the rear of the dryer and over the heat source (burner flame for gas and heating element for electric). The heated air moves through the heater duct and into the cylinder, where it circulates through the wet load. The air then passes through the lint filter, air duct, and exhaust fan, where it is vented to the outdoors.

Operating Modes and Dipswitches

Coin Slide and Non-Metered Models

Power-Up Mode

Shortly after power is applied to the dryer, the control will flash once to indicate the machine is ready to be used. If a cycle was running previously, the control will blink and then stay lit, indicating there is still time remaining from the previous cycle. If the control was not previously running a cycle, the control will be in Ready Mode.

Ready Mode

In Ready Mode, the control waits for the vend to be satisfied before entering Start Mode.

Start Mode

In Start Mode, the vend has been satisfied, but the Start button has not been pressed. The IN USE LED will be lit. The timer will not count down until the Start button is pressed.

Run Mode

In Run Mode, the control is running a cycle. The IN USE LED is lit.

Door Open Mode

In Door Open Mode, the control turns off the heater and motor when the door is opened during a run cycle. The timer will continue to count down time and the IN USE LED is lit.

End of Cycle Mode

In End of Cycle Mode, a cycle is complete and the IN USE LED is off. The control remains in this mode until the door is opened or additional vend has been satisfied.

Top-Offs (Coin Slide Models)

Any time the control receives a coin slide pulse during a cycle it will add the programmed dry time to the time currently remaining in the cycle. The IN USE LED will flash briefly to indicate the coin input. The maximum cycle time is 99 minutes. The control will not add time beyond 99 minutes. The cool down time will not change. If the control receives a coin slide pulse during cool down it will exit cool down and start heating with the cycle time equal to the programmed time.

Temperature Selector Switch

Drying temperature is selected using the Temperature Selector Switch. Temperature options for cycles are NO HEAT, LOW, MEDIUM and HIGH.

Error Display Mode

The control enters Error Display Mode to display thermistor errors. The heater is turned off, the IN USE LED flashes to indicate the error (refer to paragraphs below), and the timer will continue

to count down time. The control remains in Error Display Mode until the control senses the thermistor has returned to an acceptable heating range, the cycle ends or machine is powered down.

Open Thermistor

If the control senses a temperature less than 0°F when the heat has been on for at least three minutes it will set an open thermistor error. The control will flash the IN USE LED twice separated by a one and a half second pause. This sequence is repeated as long as the Open Thermistor error is sensed.

Shorted Thermistor

If the control senses a temperature greater than $210 \pm 4^\circ\text{F}$ during an active cycle it will set a Shorted Thermistor error. The control will flash the IN USE LED three times separated by a one and a half second pause. Unplug dryer or turn circuit breaker off/on to clear error. This sequence is repeated as long as the Shorted Thermistor error is sensed.

Setting Dry Time Dipswitches

There are two banks of dipswitches on the dryer control: Dipswitch1 and Dipswitch2. Each bank has eight switches: Dipswitch1 (Switch 1-8) and Dipswitch2 (Switch 1-8). Dipswitch1 configures machine definition. Dipswitch2 configures vended cycle definition. Refer to *Table 2* and *Table 3* for dipswitch options.

NOTE: The control reads the dipswitch settings at power-up. The control must be powered down to change the dipswitch settings.

NOTE: The control must be powered down for 10 seconds before the dipswitch can be changed.

Dipswitch1 Bank

Refer to *Table 2*.

Dipswitch1 Bank		
Switch	OFF	ON
1	120 VAC supply	240 VAC supply
2	Unused	Unused
3	Non-Vended	Vended
4	Unused	Unused
5	Unused	Unused
6	Unused	Unused
7	Unused	Unused
8	Unused	Unused

Table 2

Dipswitch2 Bank

In Dipswitch2 bank, dipswitches 1 - 6 can be used to add dry time per vend. There is always at least one minute of dry time (all switches OFF). Setting one or more dipswitches to ON extends the total dry time per vend by that amount of minutes. The maximum cycle length is 99 minutes. Heat and cooldown time combined can never be longer than 99 minutes. Refer to *Table 3*.

Dipswitch 7 specifies Cool-Down time for vended machines. The Cool-Down time is three minutes when this switch is OFF, and ten minutes when the switch is ON. For non-vended machines, Cool-Down time is determined by the position of the Temperature Selector Switch.

Dipswitch 8 is used for the cycle reset on vended machines. If the switch is OFF (default), the control will save the time left on a cycle in case of a power failure. If the switch is ON, the control will clear the cycle and return to Ready Mode if there is a power failure. On non-vended machines, the control will clear any cycle time and reset to Start Mode, regardless of the positions of these dipswitches.

Dipswitch2 Bank		
Switch	OFF	ON
1	No additional dry time per vend	Plus 1 minute dry time per vend
2	No additional dry time per vend	Plus 2 minute dry time per vend
3	No additional dry time per vend	Plus 4 minute dry time per vend
4	No additional dry time per vend	Plus 8 minute dry time per vend
5	No additional dry time per vend	Plus 16 minute dry time per vend
6	No additional dry time per vend	Plus 32 minute dry time per vend
7	Short Cool-Down time	Long Cool-Down time
8	Save cycle time on long powerfail	Clear cycle time on long powerfail

Table 3

Resetting Cycle Time to Zero

To remove any cycle time that may have accumulated on the control during setup, the cycle time on the control can be reset to zero.

To reset the time, unplug the dryer and set dipswitch 8 to ON position. Restore power to the dryer for 10 seconds and once again

unplug dryer. Set dipswitch 8 to OFF position and restore power to the dryer.

Test Setting

When testing coin slide operation or other troubleshooting, set dipswitch with this shorter cycle:

1. Unplug the machine power cord.
2. Record the machine control dipswitch settings. Then set them all to the off position. Refer to *Figure 1*.
3. Plug in the machine and initiate a cycle.

NOTE: With all the control dipswitches off, the total cycle time will be four minutes long.

4. Once all the testing is complete, unplug the machine and reset the dipswitches to their original settings.
5. Plug in the machine.

Dryer Troubleshooting



WARNING

To reduce the risk of electric shock, fire, explosion, serious injury or death:

- **Disconnect electric power to the dryer before servicing.**
- **Close gas shut-of valve to gas dryer before servicing.**
- **Never start the Dryer with any guards/panels removed.**
- **Whenever ground wires are removed during servicing, these ground wires must be reconnected to ensure that the dryer is properly grounded.**

W001R1

IMPORTANT: Refer to wiring diagram for aid in testing dryer components.

Dryer Motor Does Not Run

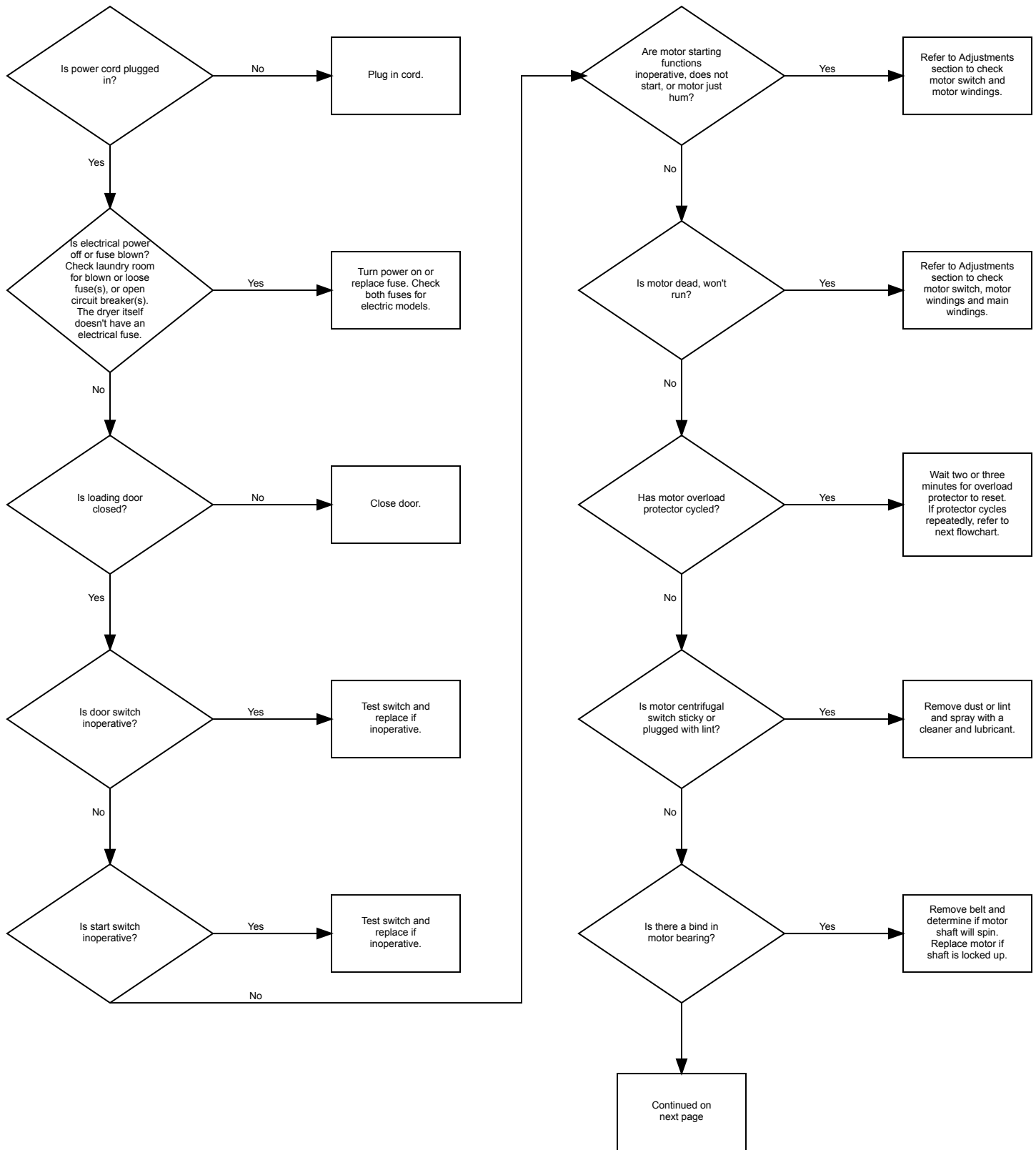

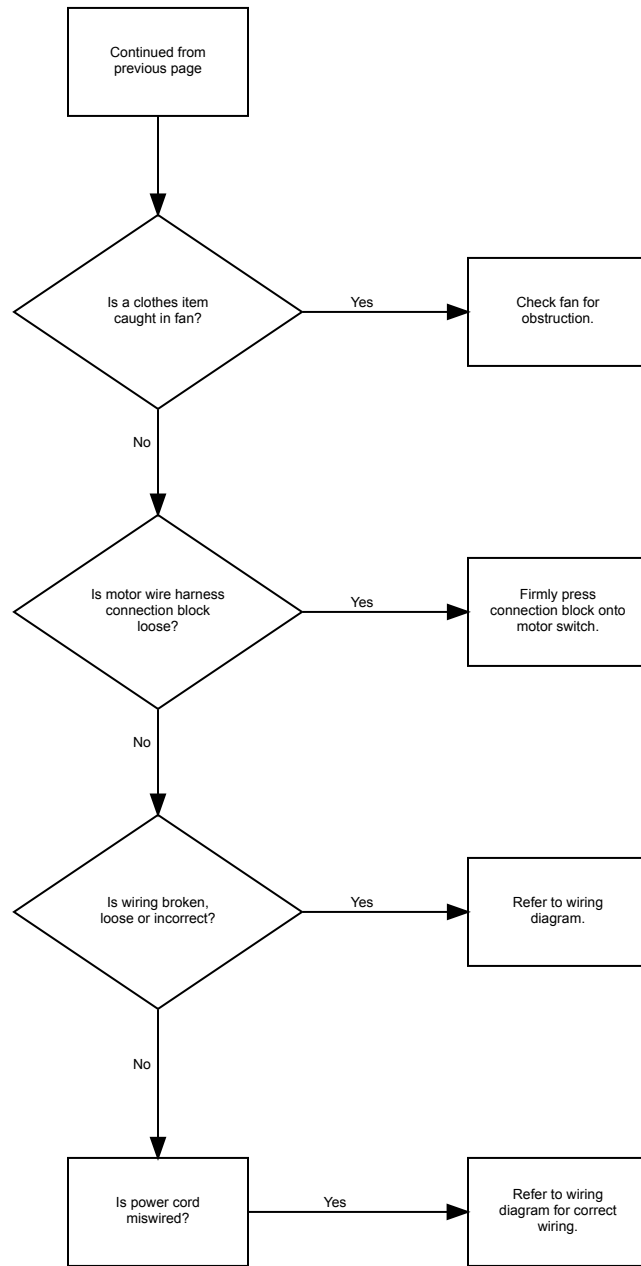

Dryer Stops in Cycle; Quits After the First Few Loads; Has a Burning Smell; Cycles on Motor Thermal Protector

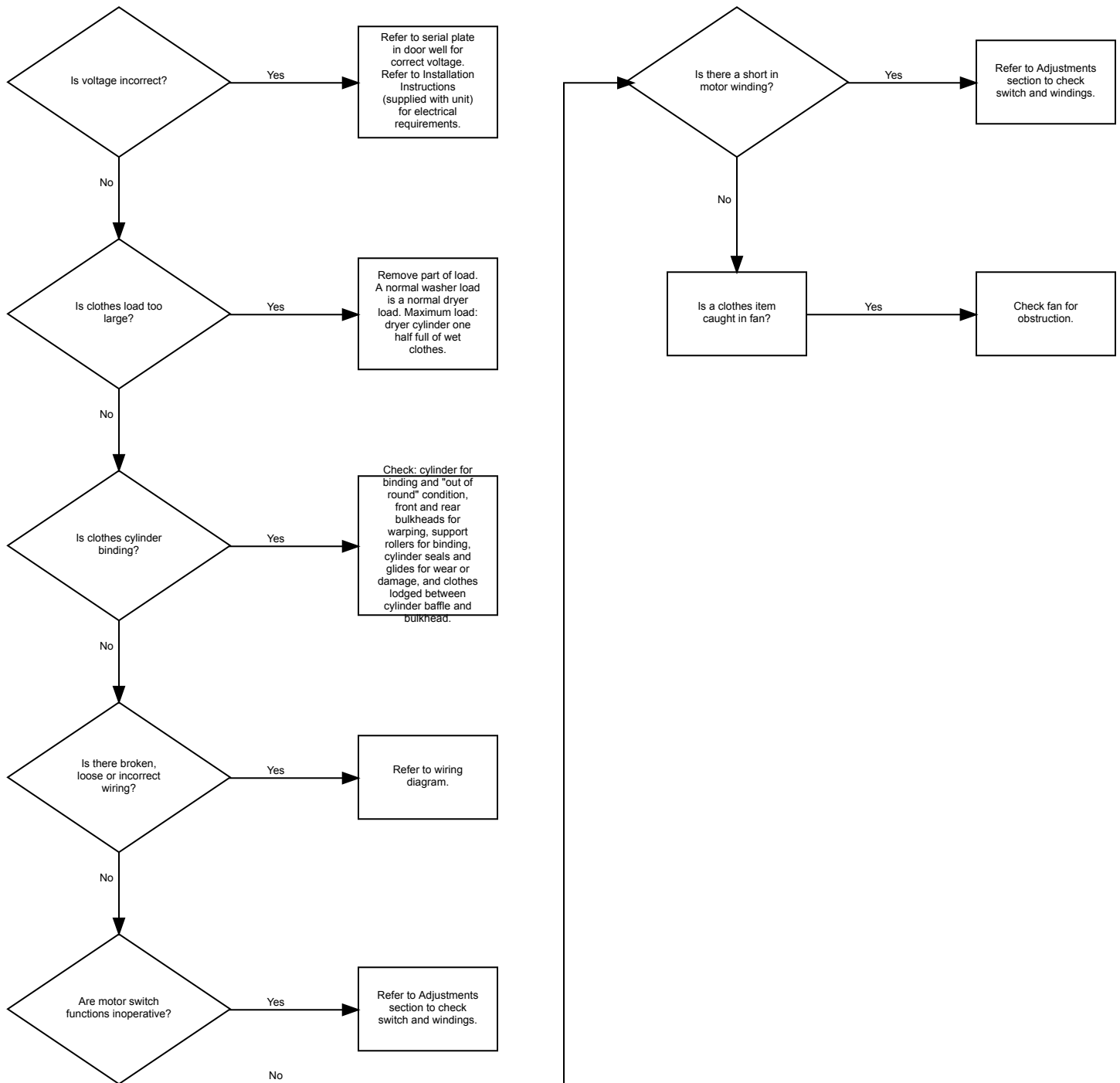

Dryer Motor Runs but Cylinder Does Not Turn

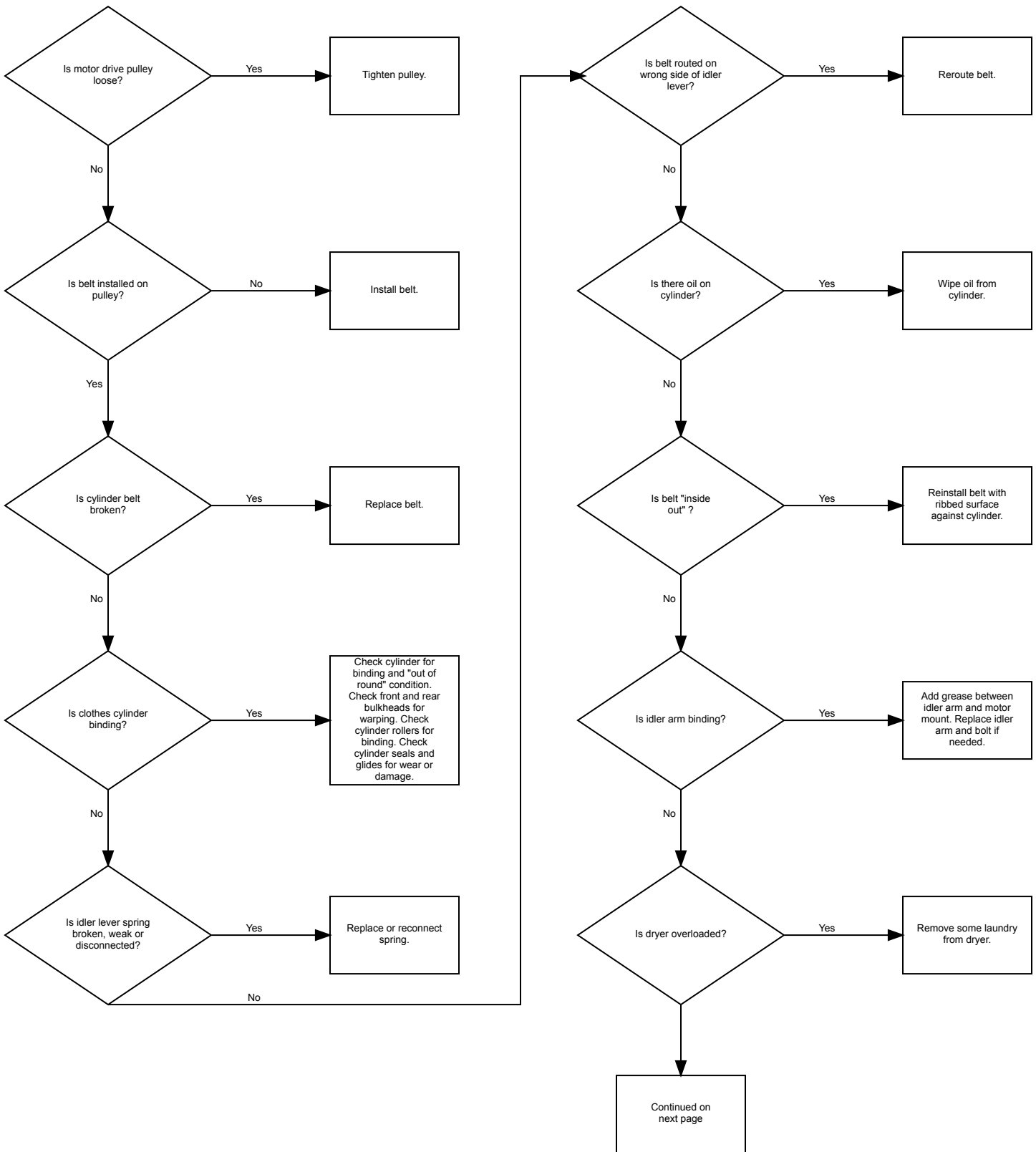

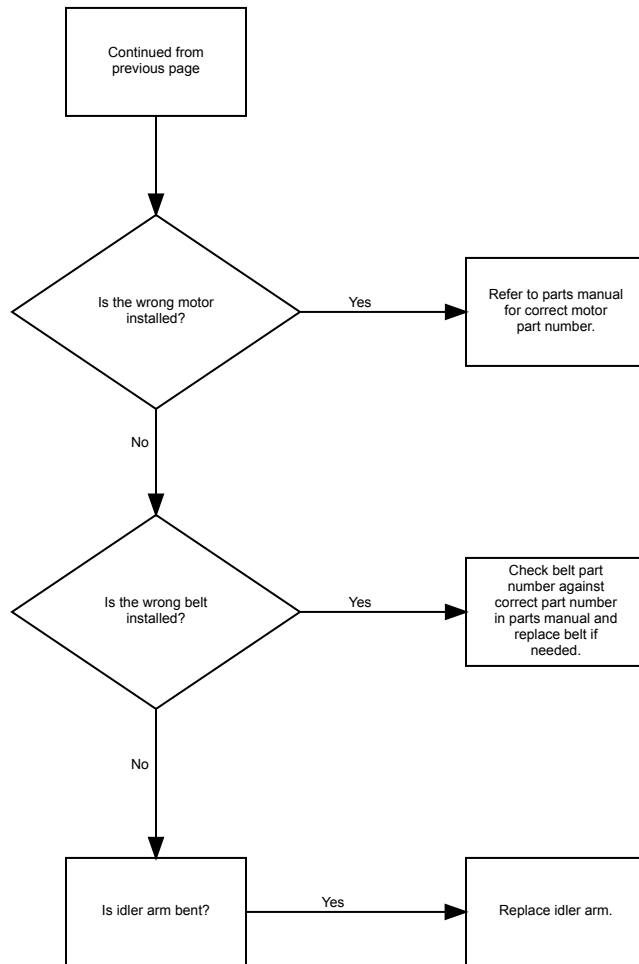

Dryer Motor Does Not Stop

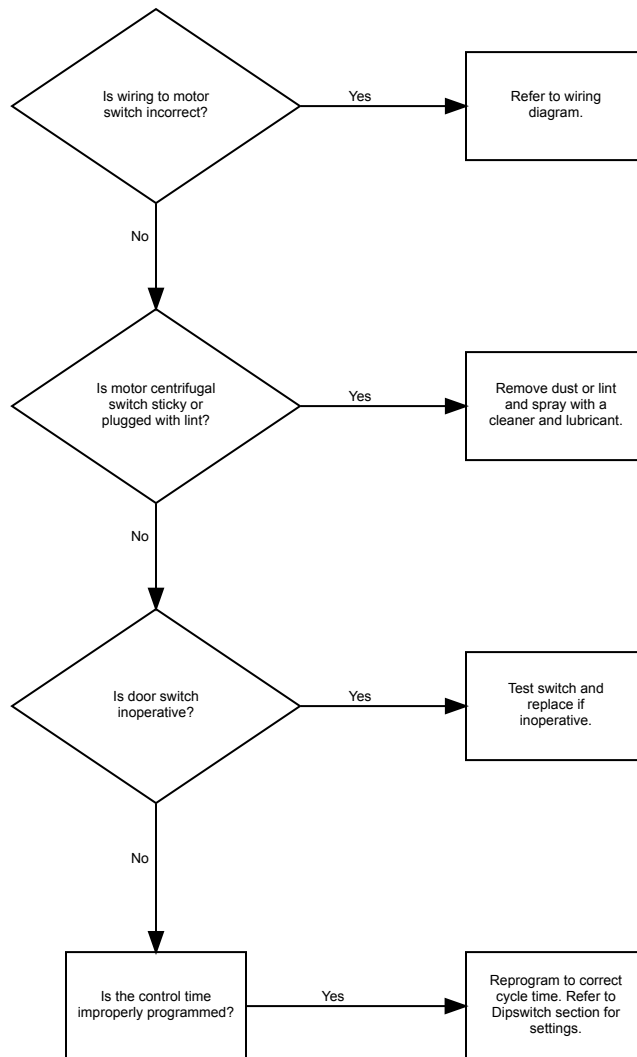

Dry Runs Only When Door is Open

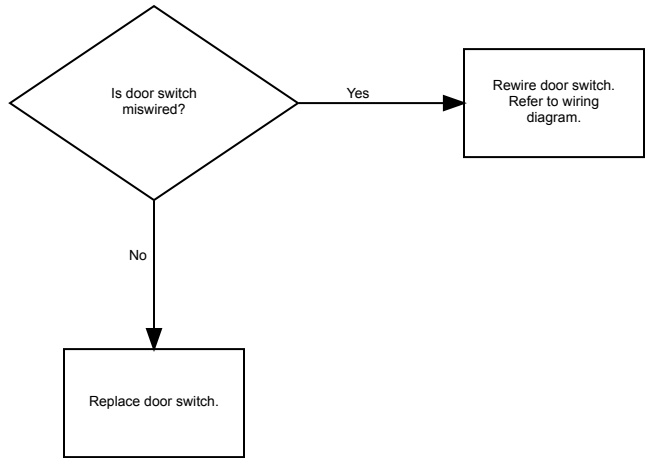

Dryer Heating Assembly Does Not Heat or Burner Does Not Ignite

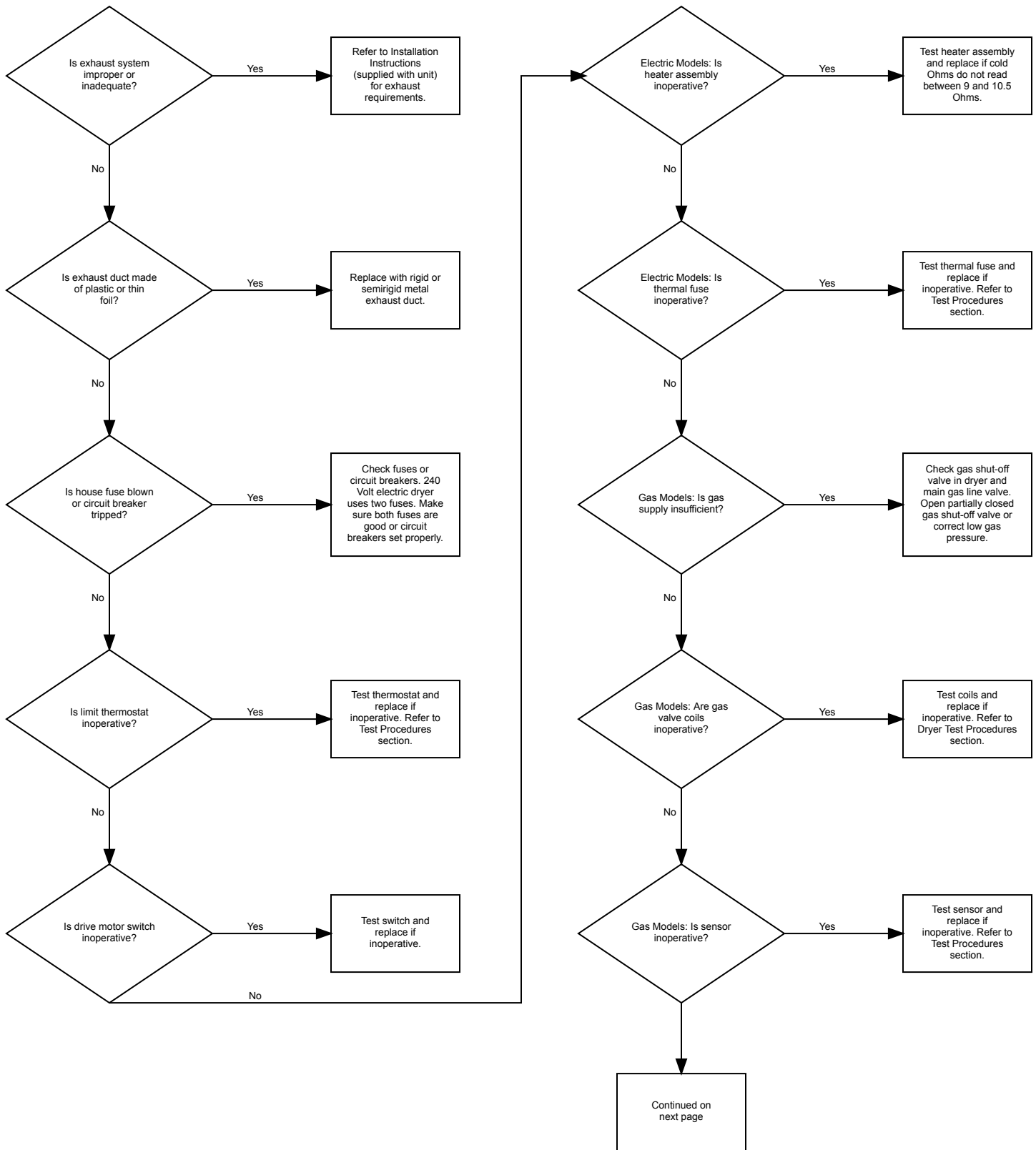

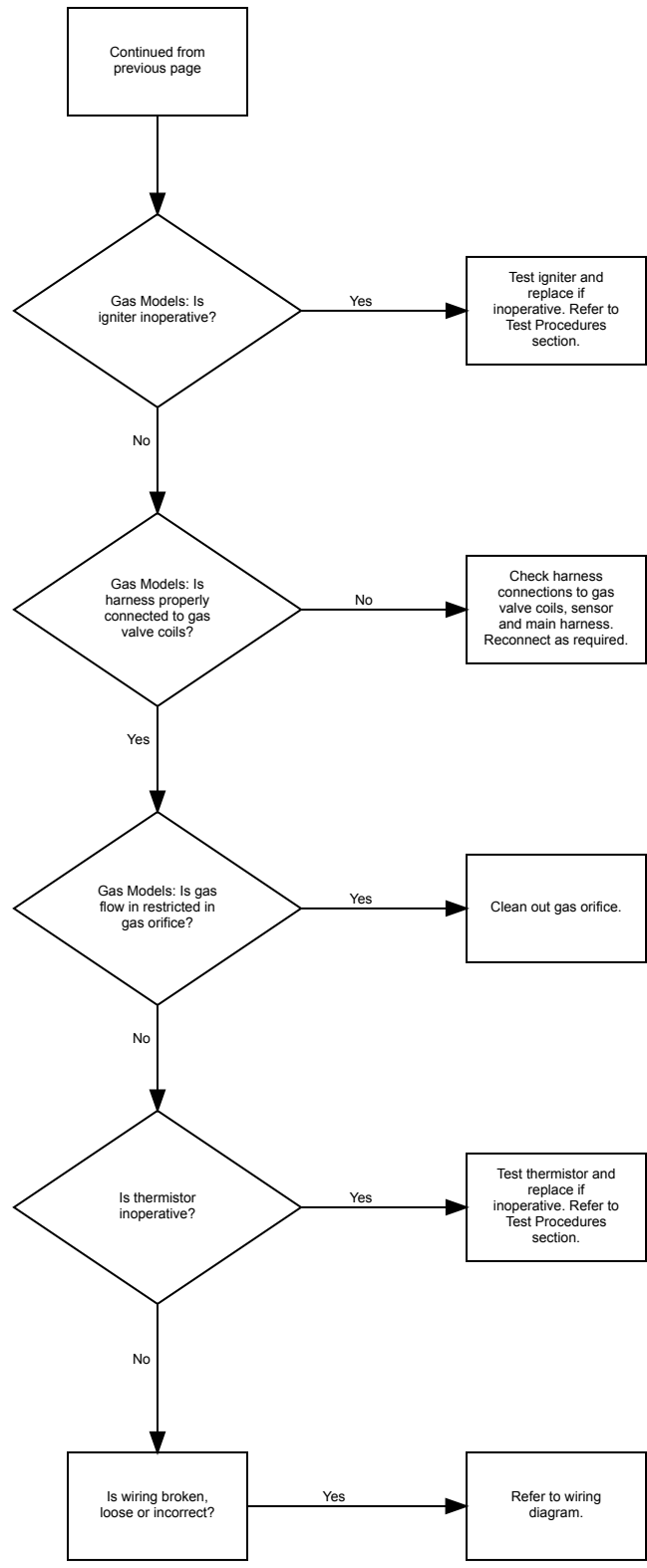

Igniter Does Not Glow (Gas Supply Sufficient) - Gas Dryer Models

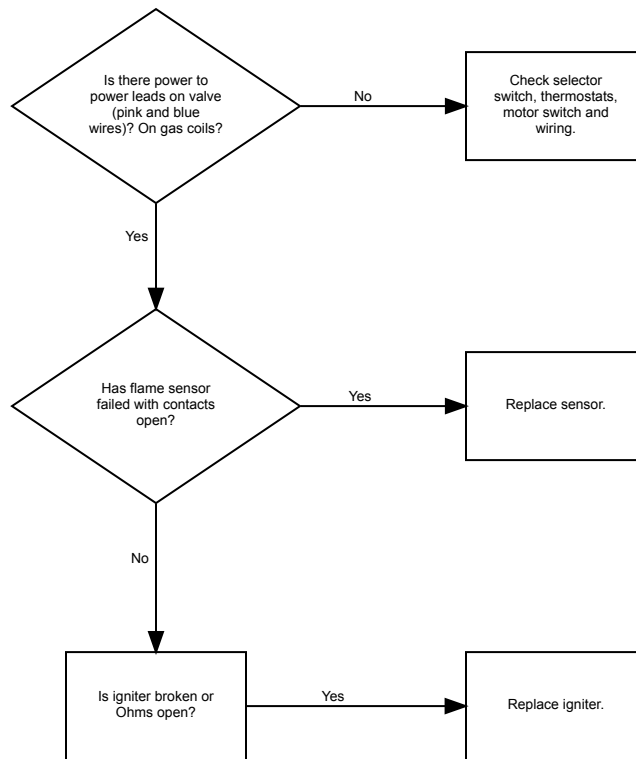

Burner Ignites and Goes Out Repeatedly (Gas Dryer Models)

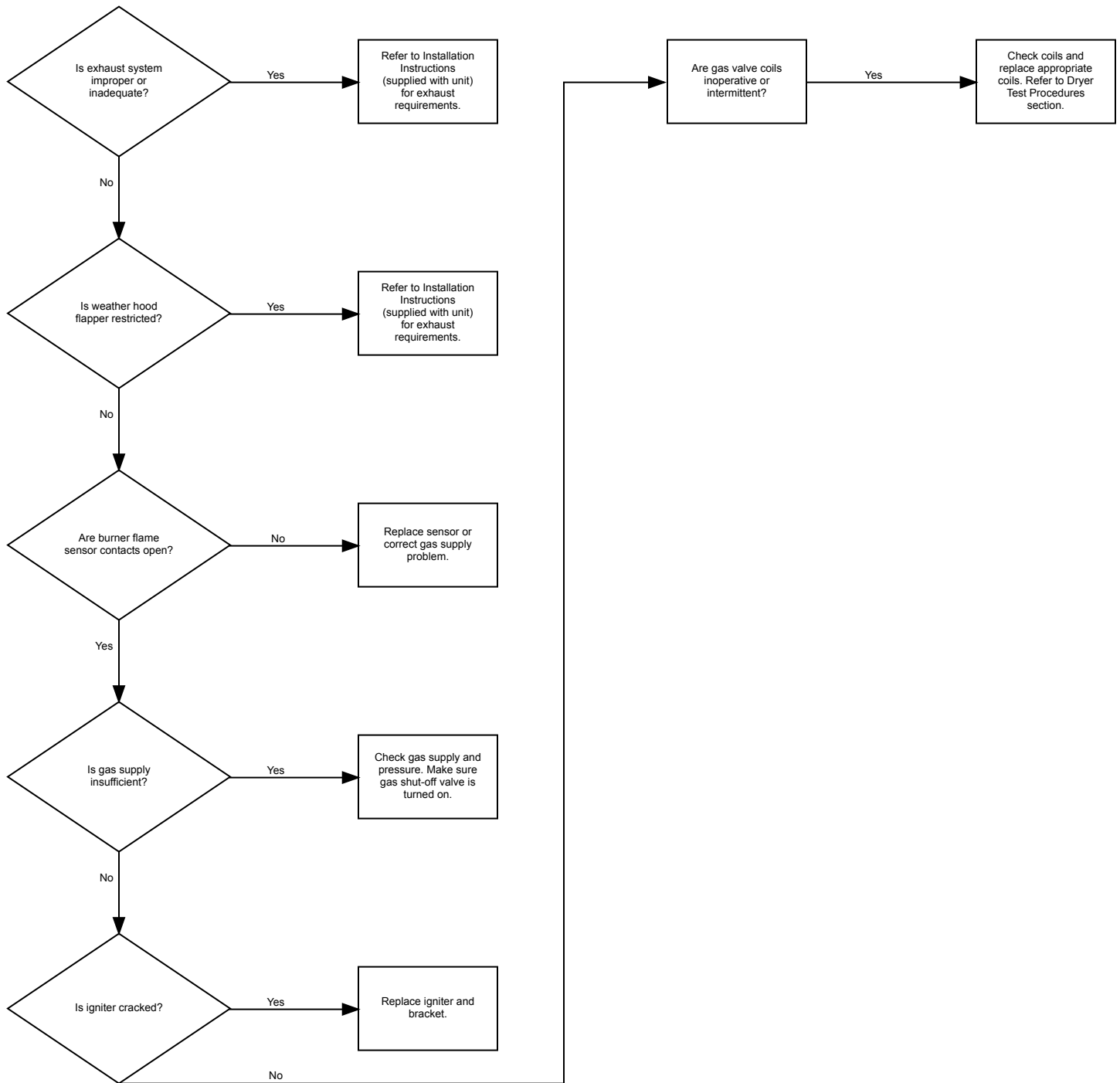

Igniter Glows but Burner Does Not Ignite (Gas Dryer Models)

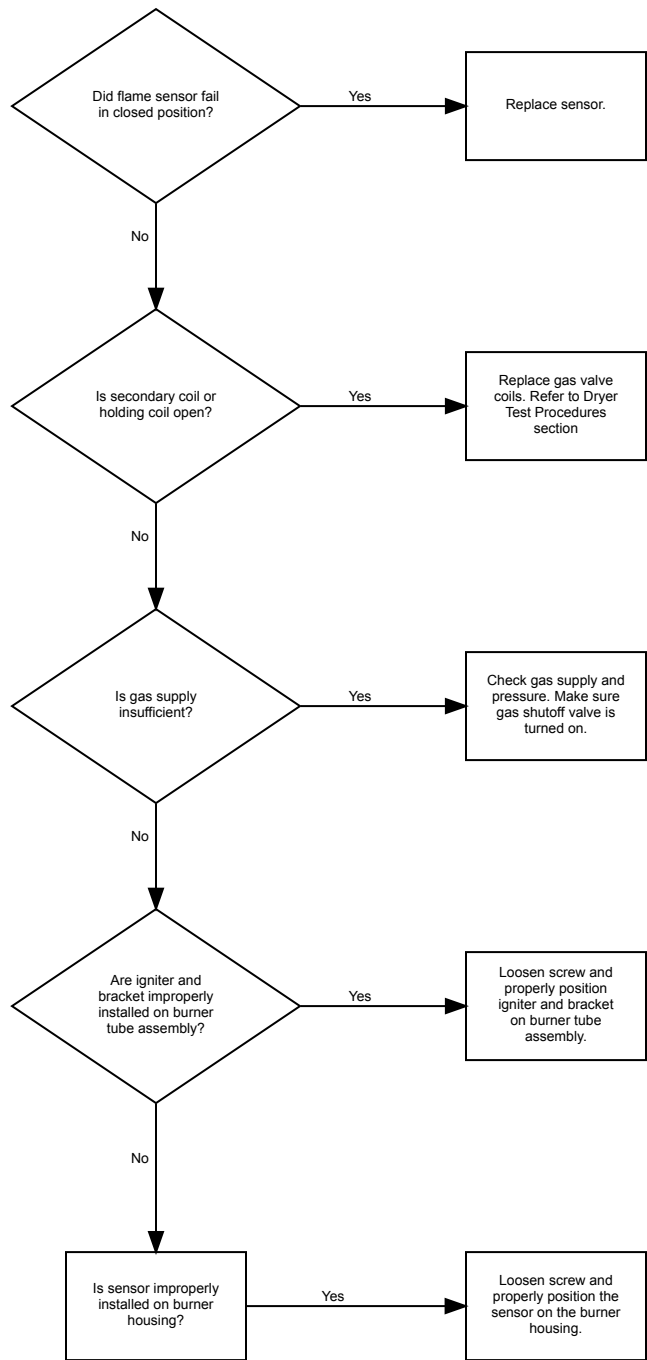

Dryer Heater Assembly or Burner Shuts Off Prematurely

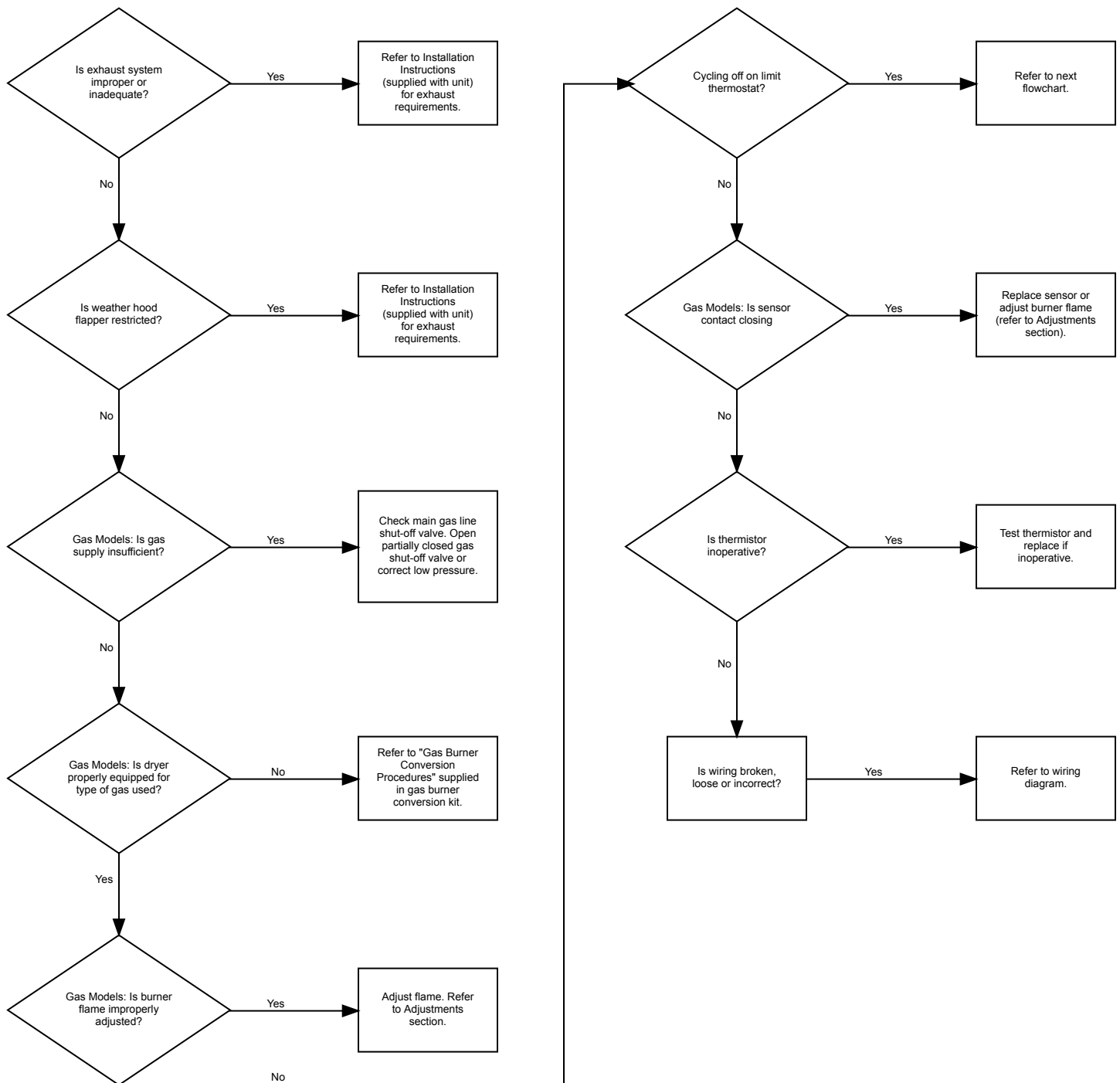

Dryer Heater Assembly or Burner Repeatedly Cycles Off On Limit Thermostat

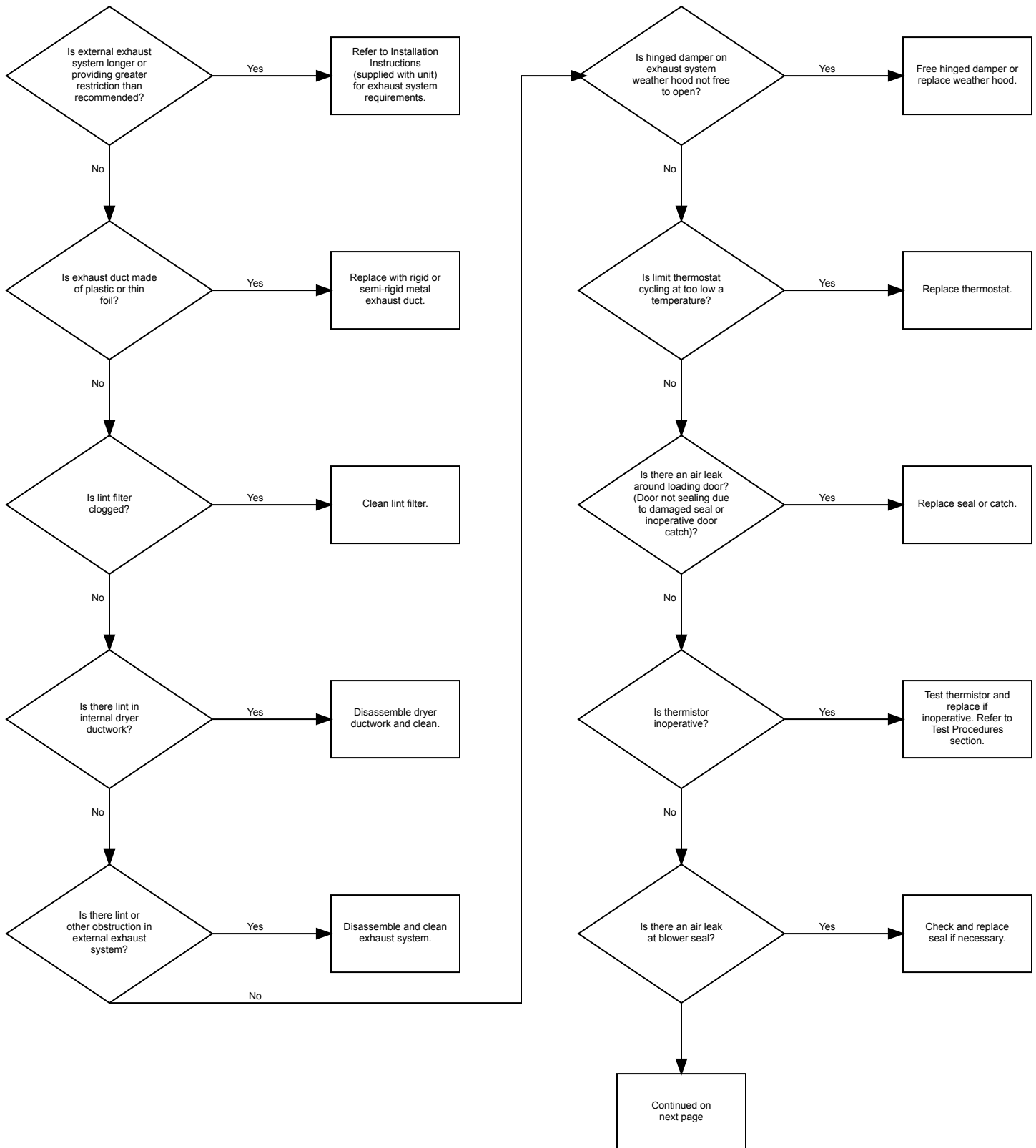

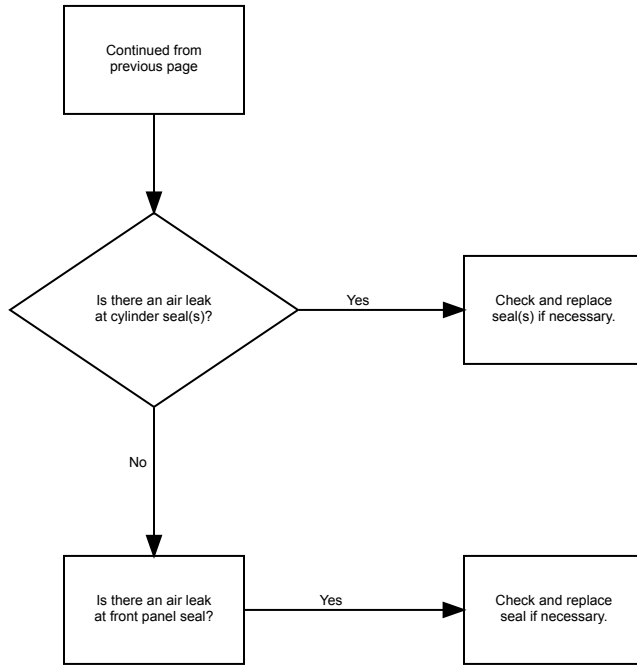

Dryer Heater Assembly or Burner Does Not Shut Off

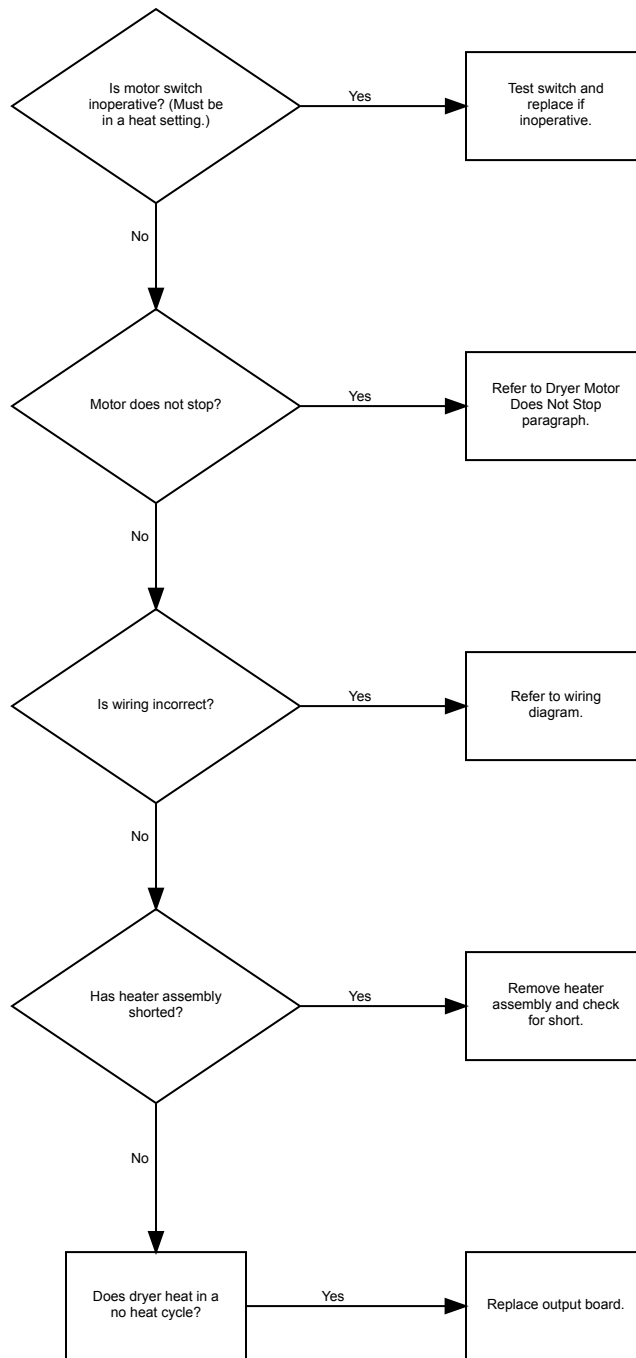

Clothes Do Not Dry in Dryer

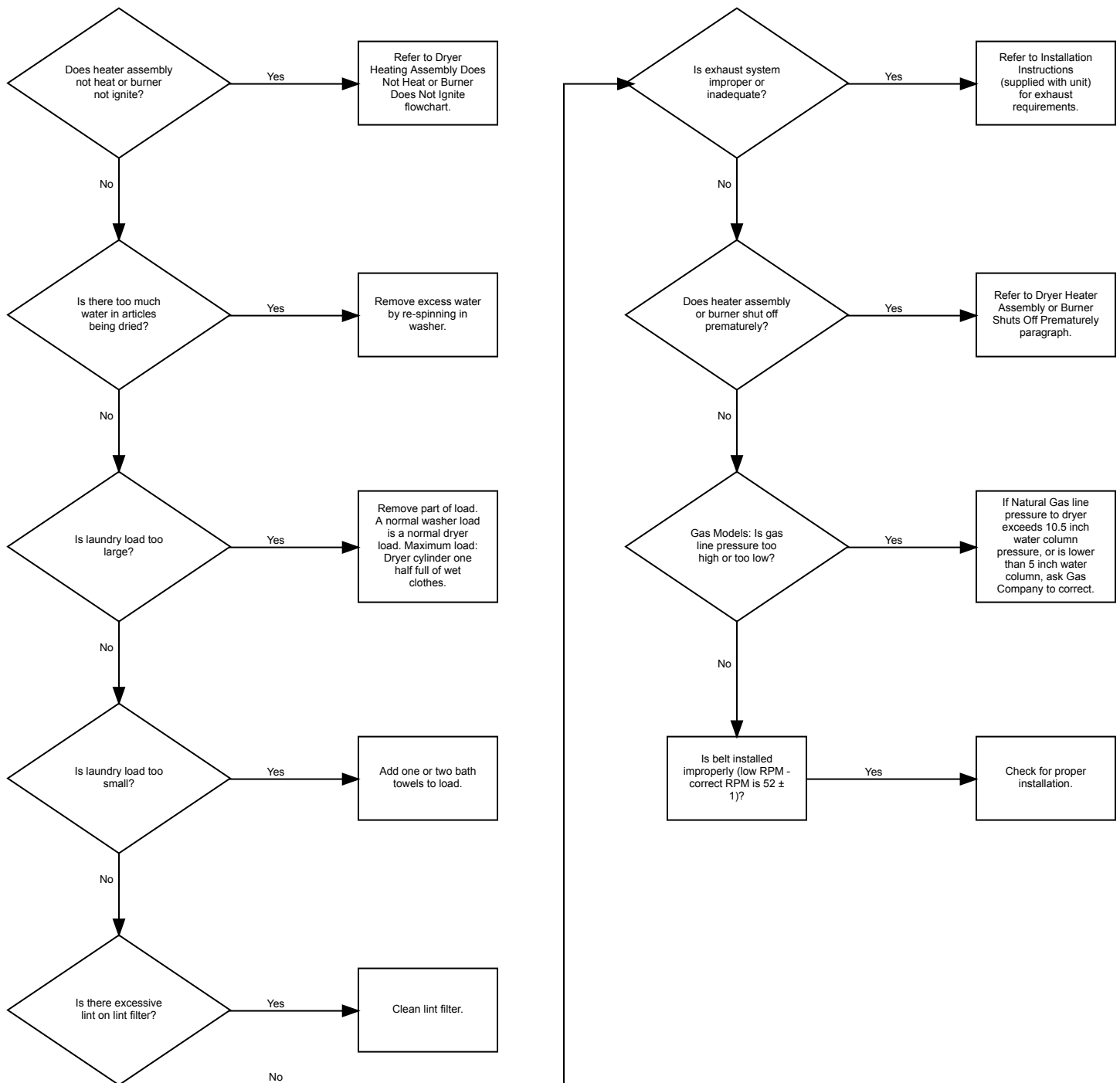

Clothes Are Too Hot When Removed From Dryer

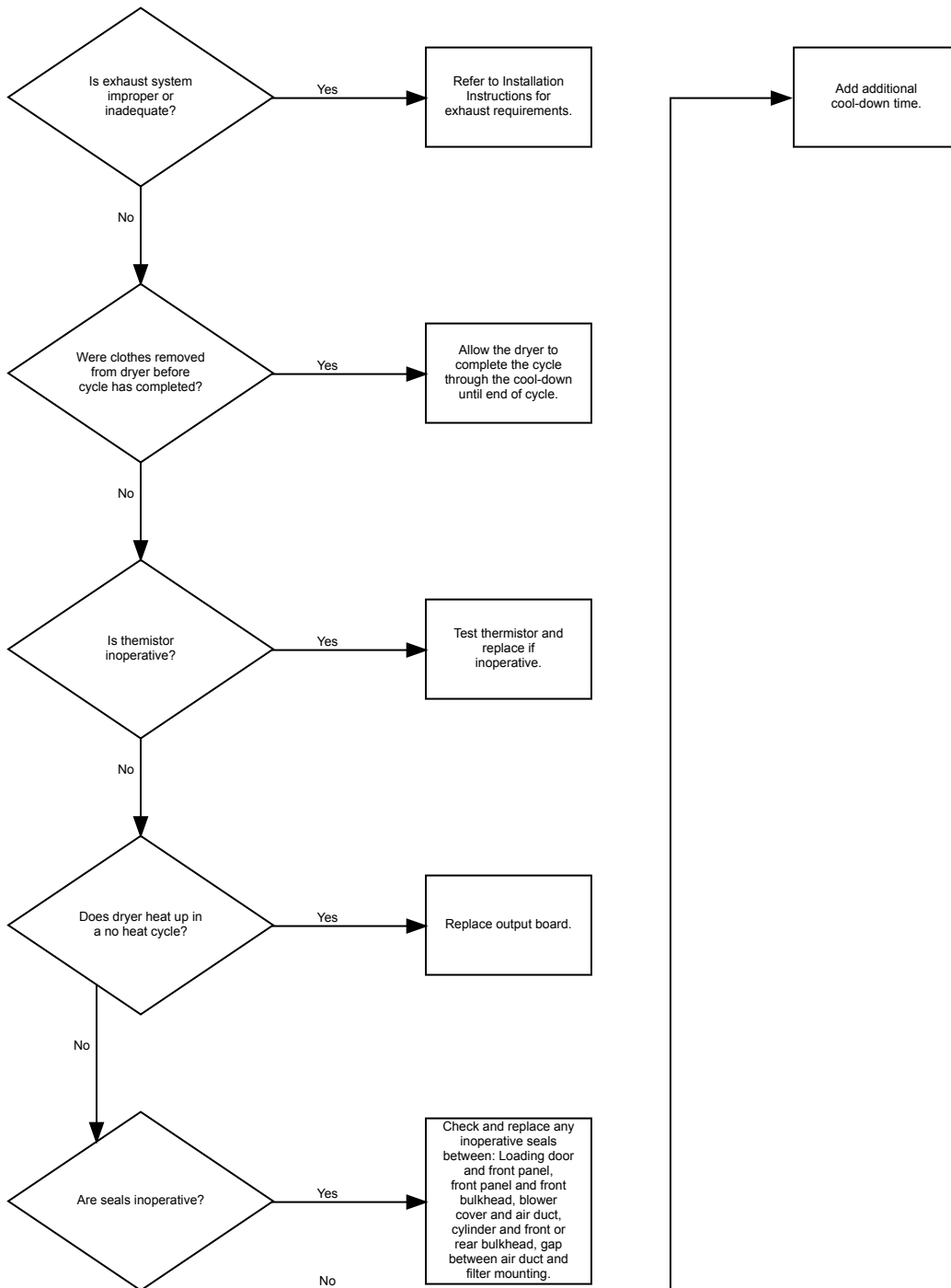

Excessive Chattering or Vibrating Noise in Dryer

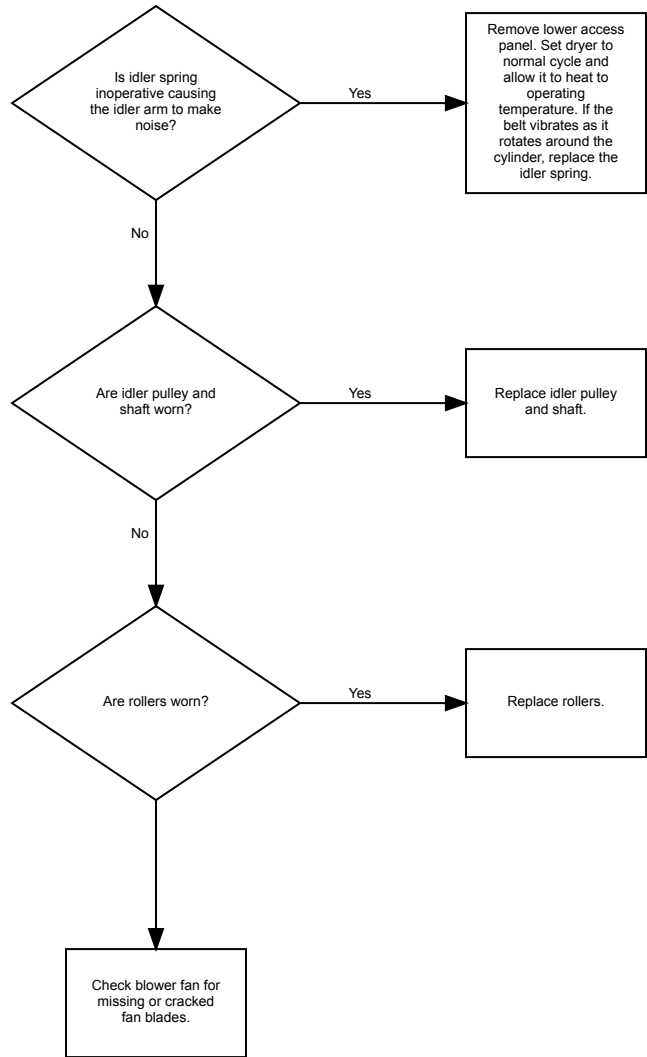

Excessive Humming or Whistling Noise in Dryer

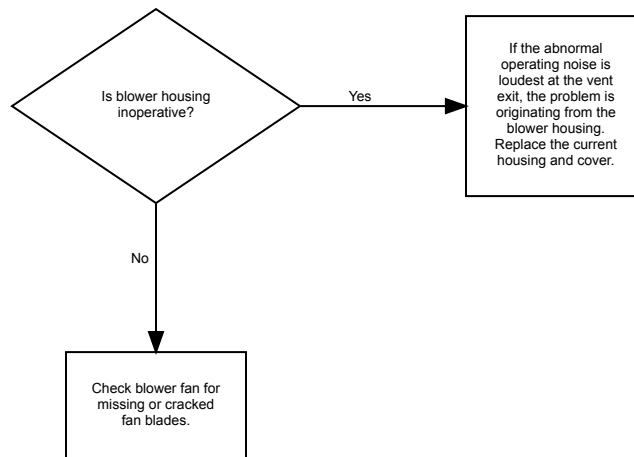

Coin Slide Control Troubleshooting



WARNING

To reduce the risk of electric shock, fire, explosion, serious injury or death:

- **Disconnect electric power to the dryer before servicing.**
- **Close gas shut-of valve to gas dryer before servicing.**
- **Never start the Dryer with any guards/panels removed.**
- **Whenever ground wires are removed during servicing, these ground wires must be reconnected to ensure that the dryer is properly grounded.**

W001R1

IMPORTANT: Refer to wiring diagram for aid in testing components.

No Cycle Start When the Coin Slide is Activated

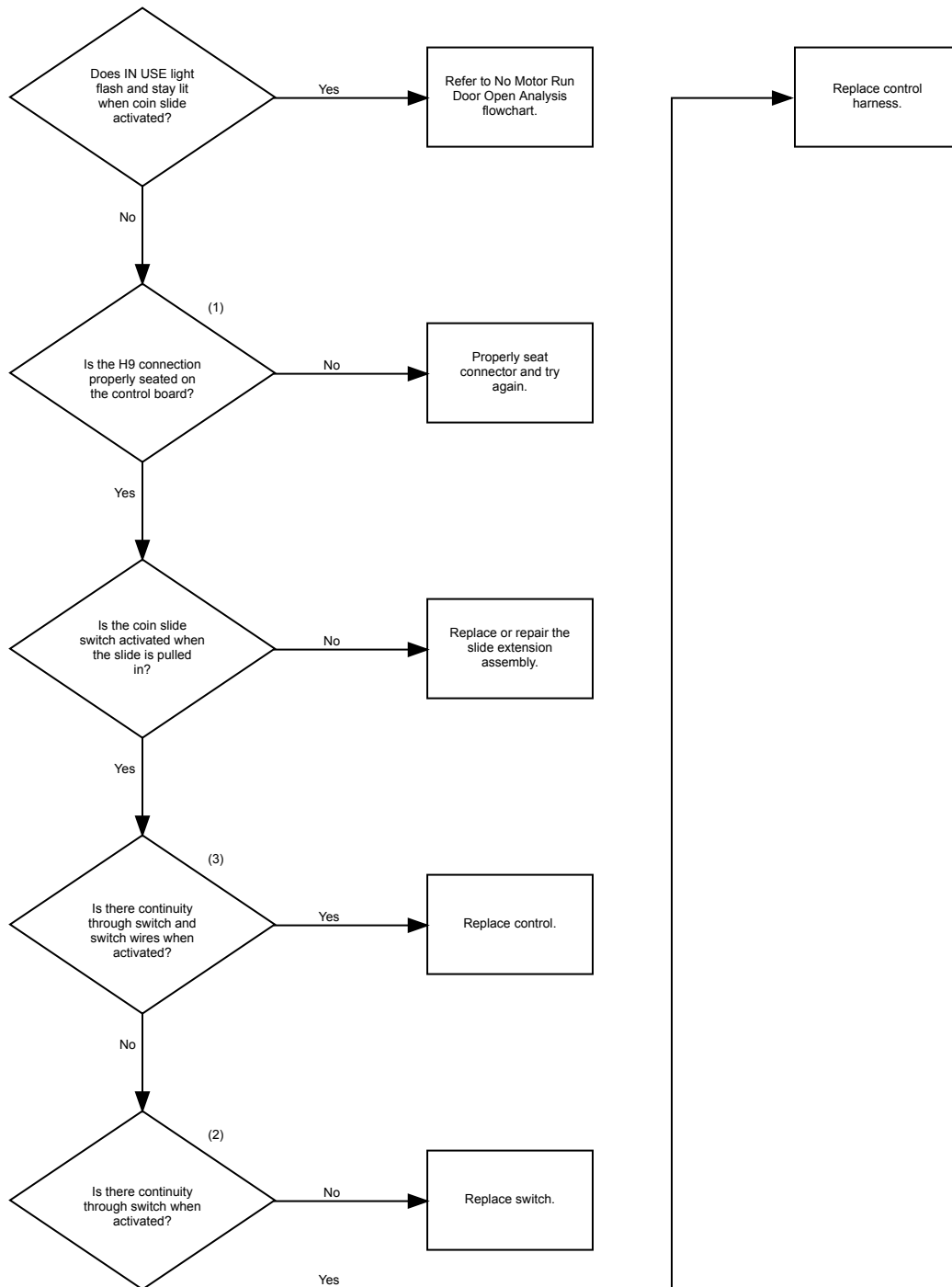

Gas Dryer - No Motor Run - Door Open Analysis

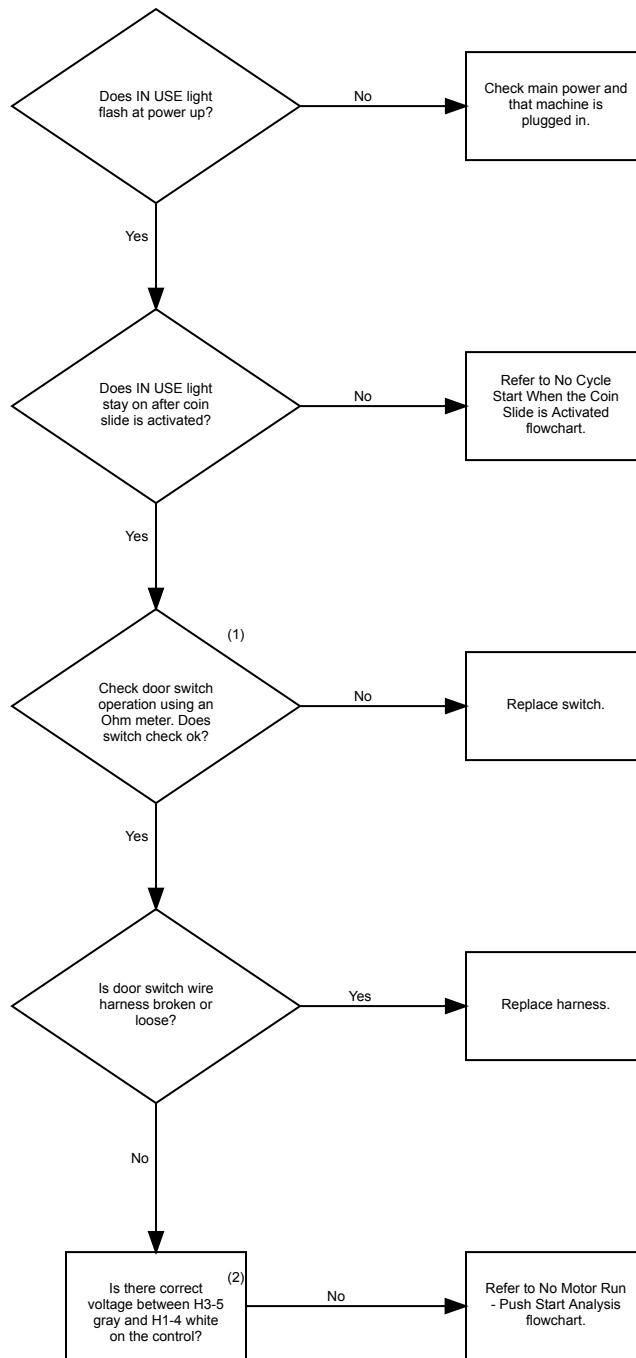

Gas Dryer - No Motor Run - Door Open Analysis

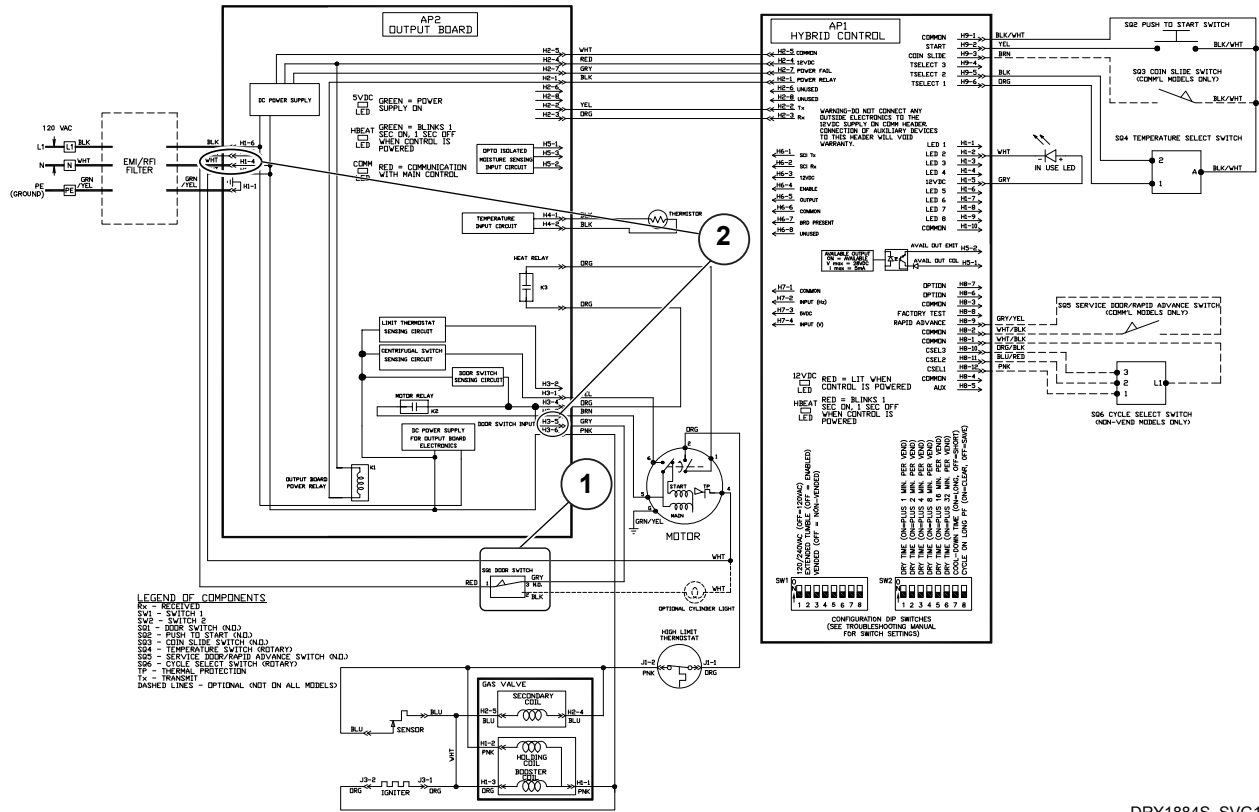

DRY1884S_SVG1

Gas Dryer - No Motor Run - Push Start Analysis

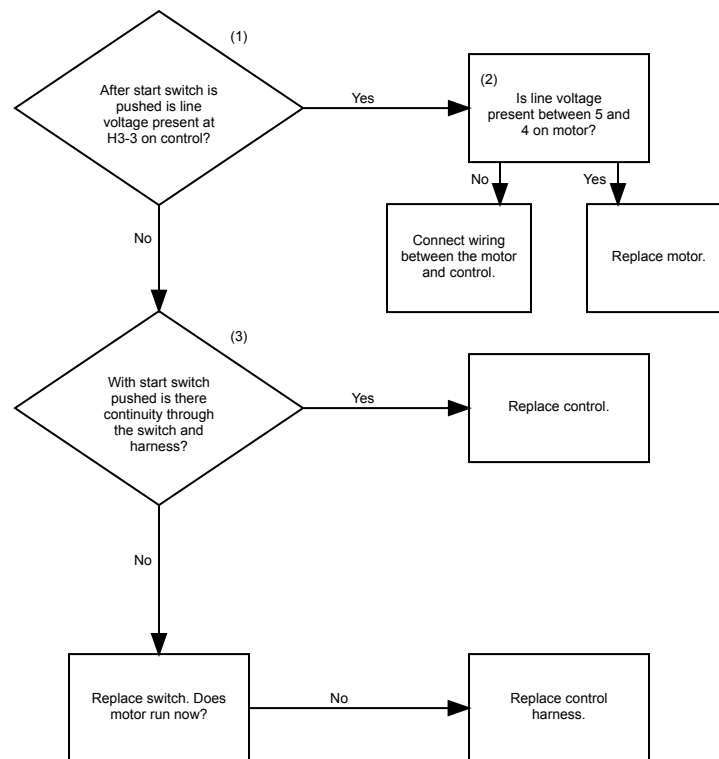

Gas Dryer - No Heat Analysis

NOTE: Dryer needs to be running in a heating mode. The following voltage measurements are 120. This also assumes there are no thermistor errors present.

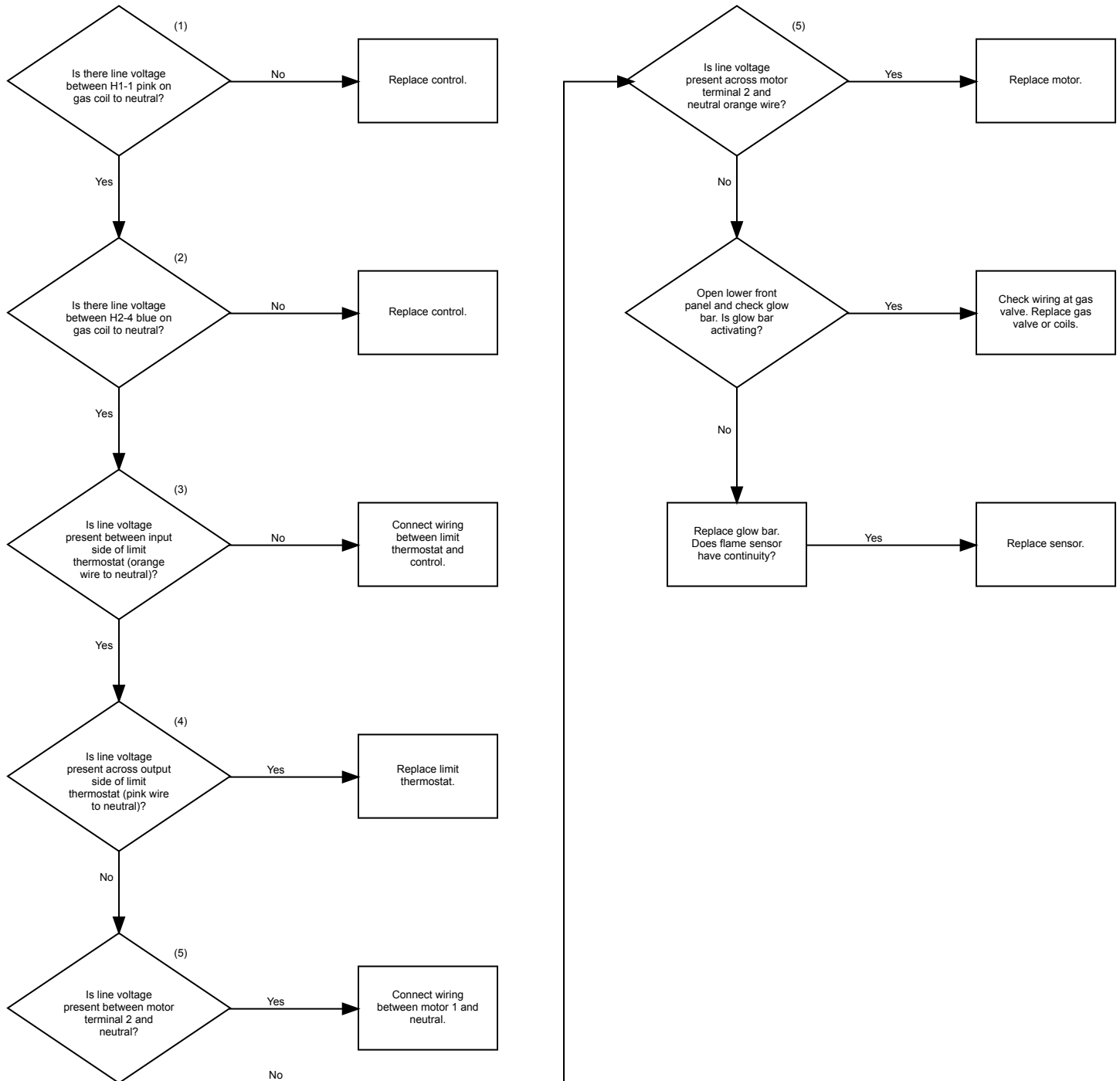

Gas Dryer - No Heat Analysis

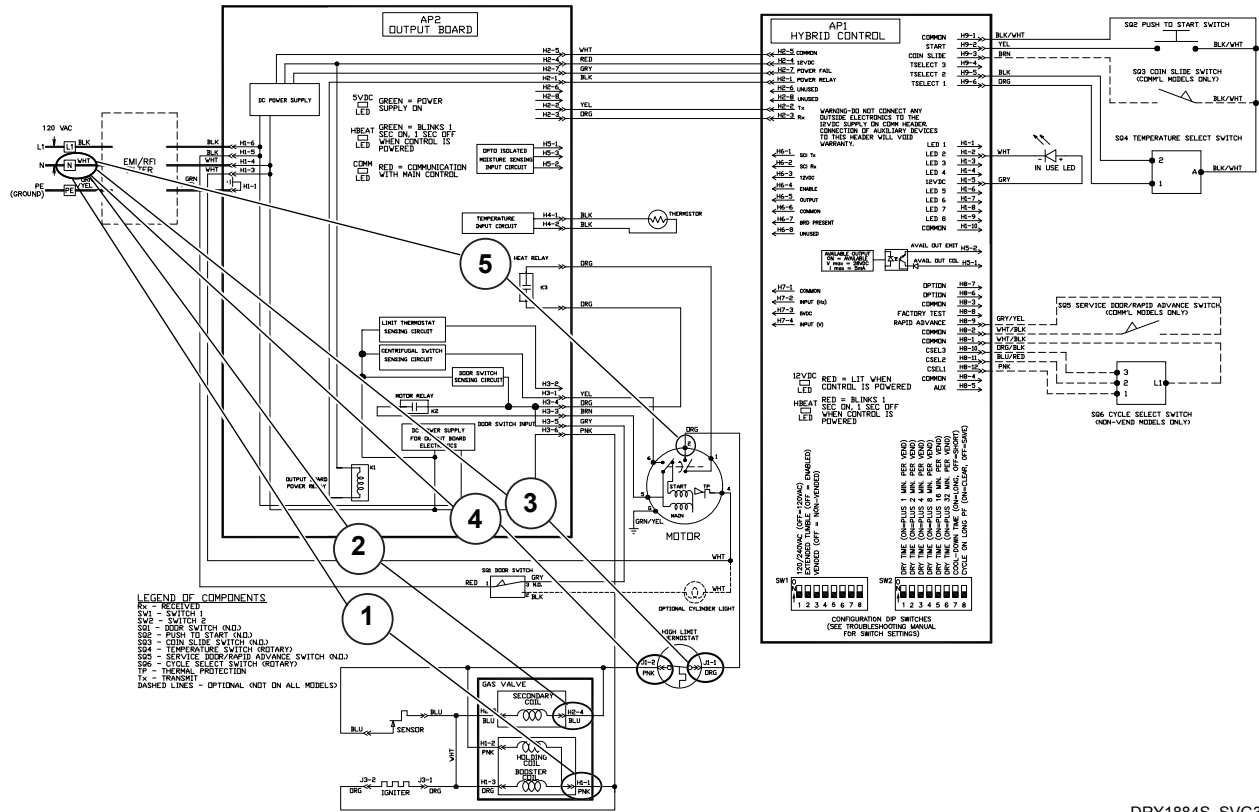

DRY1884S_SVG3

Electric Dryer - No Motor Run - Door Open Analysis

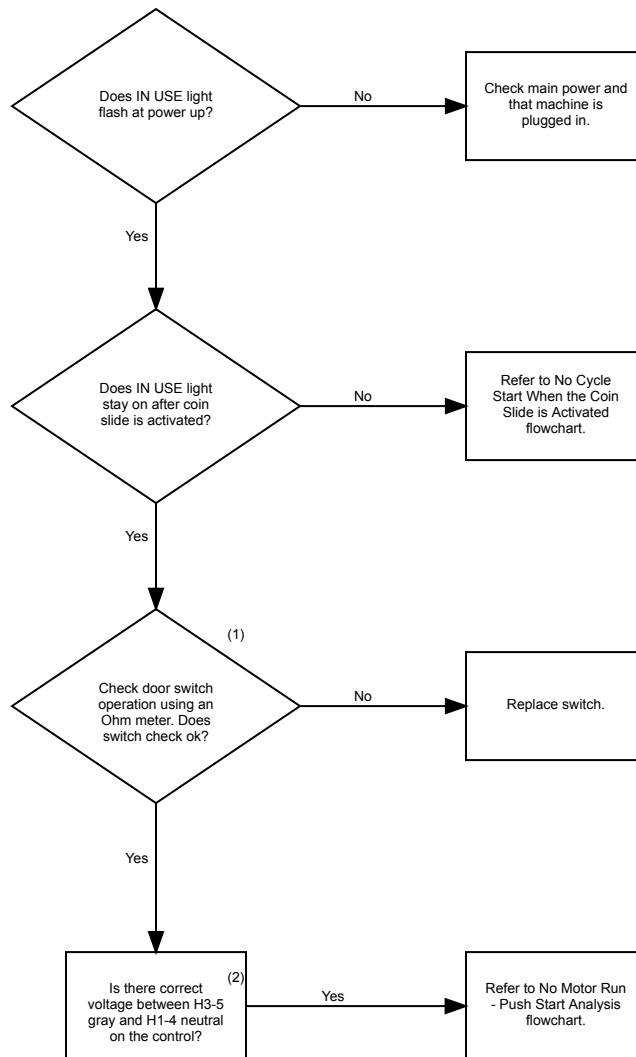

Electric Dryer - No Motor Run - Door Open Analysis

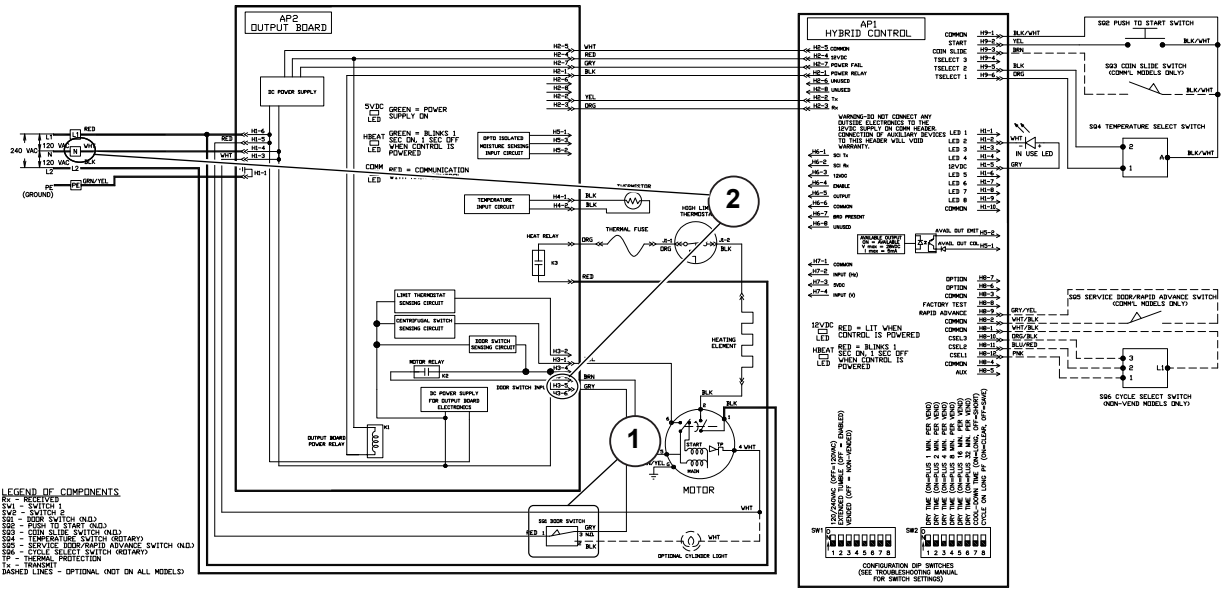

DRY1883S_SVG2

Electric Dryer - No Motor Run - Push Start Analysis

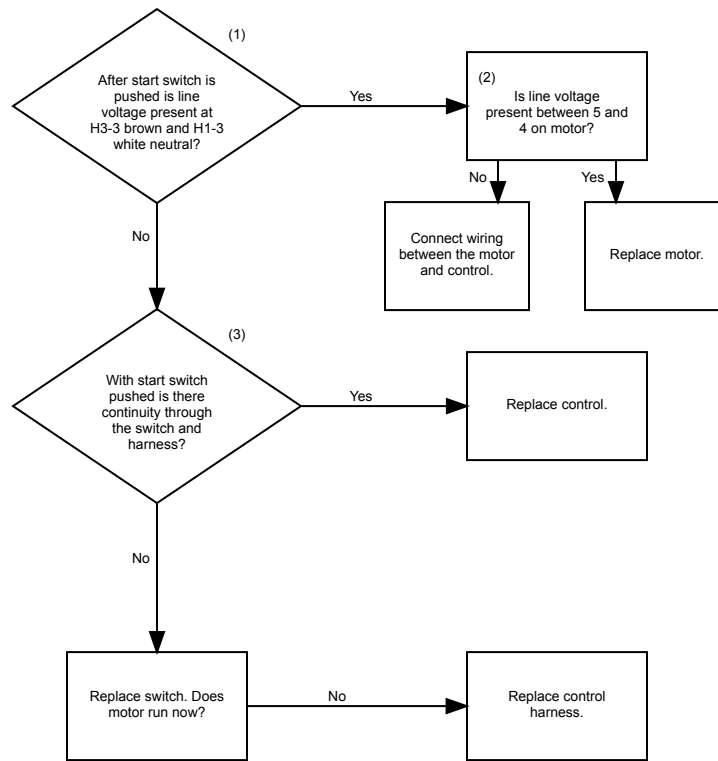

Electric Dryer - No Motor Run - Push Start Analysis

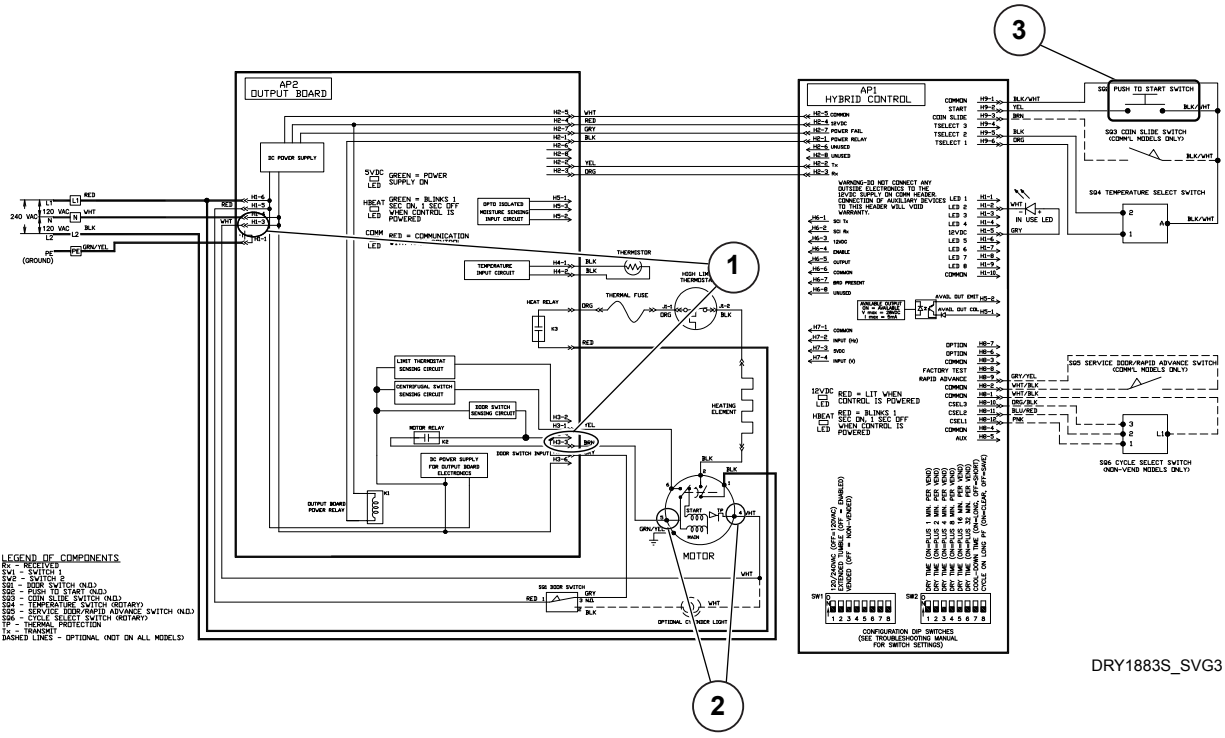

Electric Dryer - No Heat Analysis

NOTE: Dryer needs to be running in a heating mode. The following voltage measurements are 240. This also assumes there are no thermistor errors present.

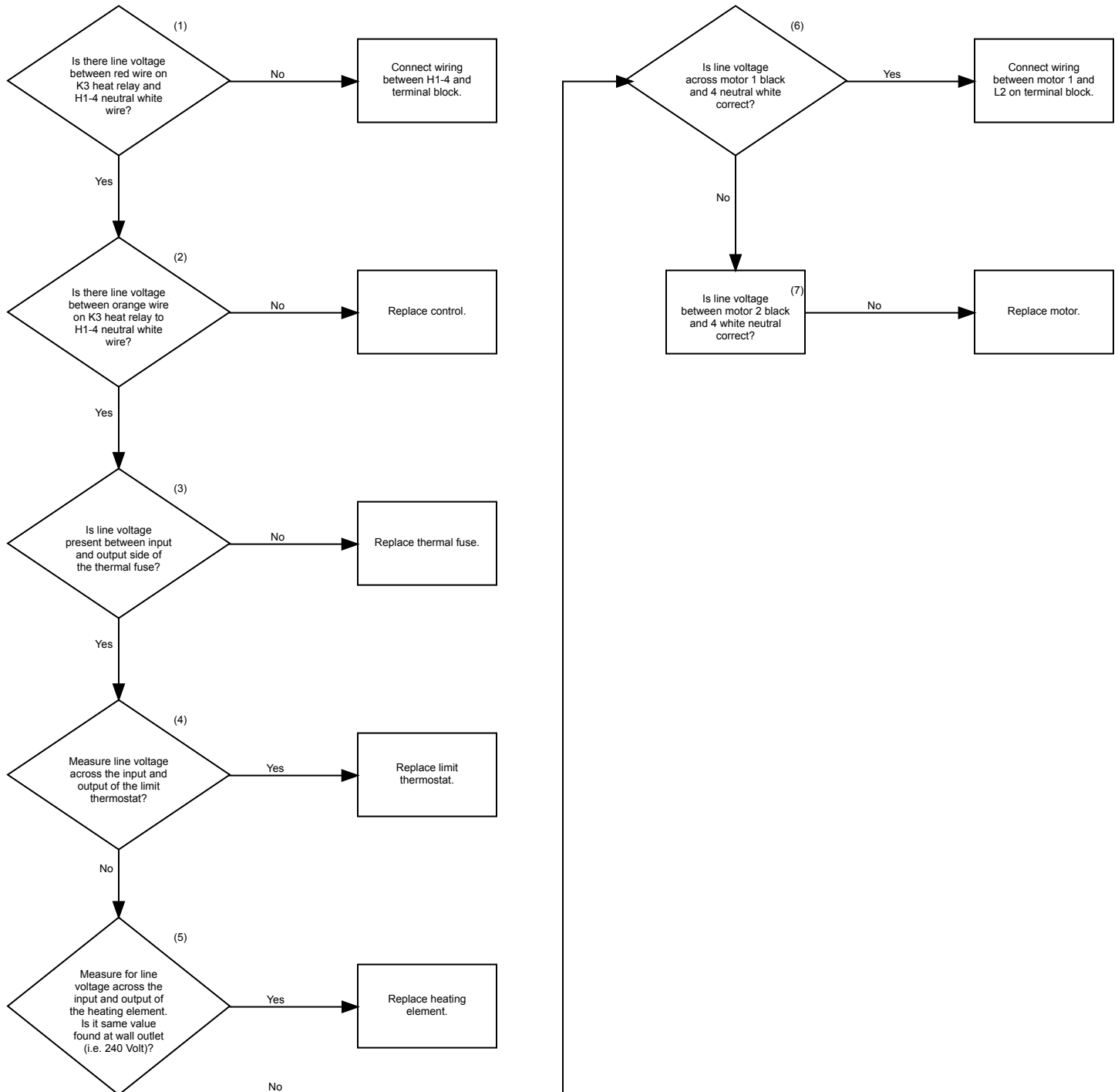

Electric Dryer - No Heat Analysis

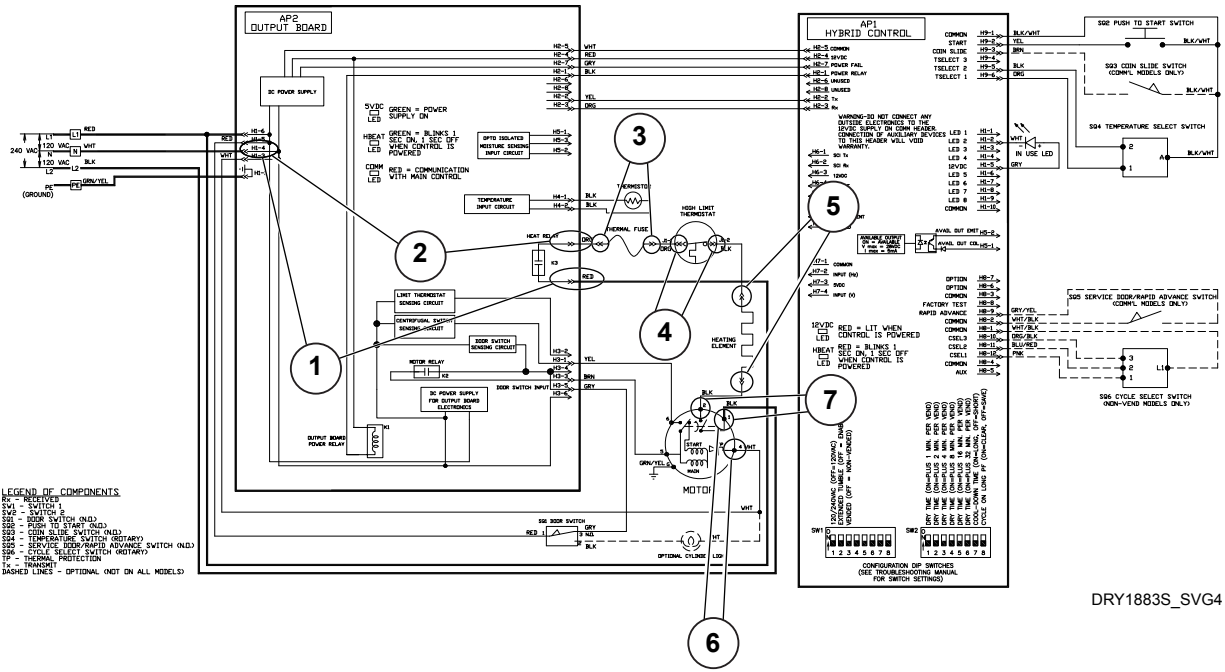

Adjustments

	WARNING
<p>To reduce the risk of electric shock, fire, explosion, serious injury or death:</p> <ul style="list-style-type: none"> • Disconnect electric power to the dryer before servicing. • Close gas shut-of valve to gas dryer before servicing. • Never start the Dryer with any guards/panels removed. • Whenever ground wires are removed during servicing, these ground wires must be reconnected to ensure that the dryer is properly grounded. 	
W001R1	

IMPORTANT: When reference is made to directions (right or left) in this manual, it is from operator's position facing front of washer.

Leveling Legs

Refer to *Figure 2*.

NOTE: Dryer should be installed on a solid and level floor.

1. Place dryer in position, adjusting the legs until dryer is level.

	WARNING
<p>To reduce the risk of serious injury or death by carbon monoxide and other gases in gas dryers, carefully read and follow all instructions given in this section.</p>	
W005	

NOTE: Legs can be adjusted outside the dryer by using a 1-1/4 inch size wrench, or from inside the dryer (with lower front access panel removed) by using a 1/4 inch drive ratchet with extension.

2. Keep dryer as close to the floor as possible. All four legs must rest firmly on the floor so weight of the dryer is evenly distributed. The dryer **MUST NOT** rock.

IMPORTANT: DO NOT move the dryer at any time unless the dryer is completely assembled. DO NOT slide the dryer across the floor once the leveling legs have been extended as the legs and base could become damaged

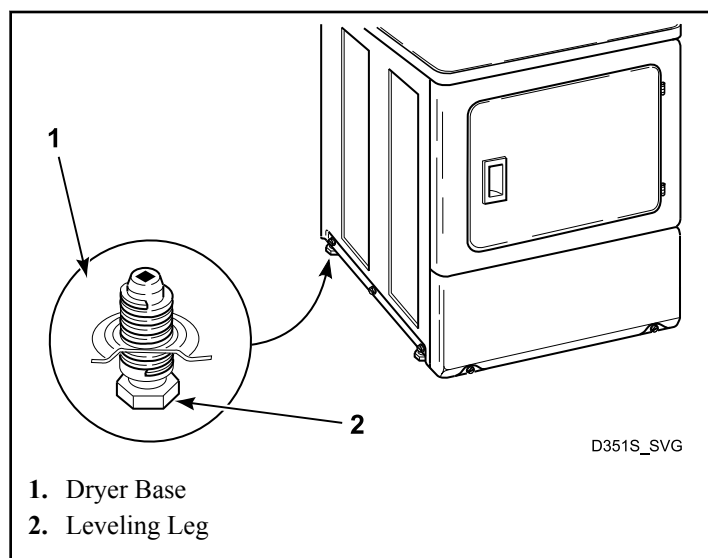

Figure 2

Burner Flame (Gas Models)

1. While supporting the access panel, remove two screws from bottom edge of access panel.
2. Gently lower the access panel to disengage locators from bottom edge of front panel.
3. Set drying time to 60 minutes, if applicable.
4. Close the loading door. Start the dryer in a heat setting (refer to dryer's Operating Instructions). The dryer will start, the igniter will glow red, and the main burner will ignite.
5. Allow the dryer to operate for approximately five minutes, then loosen the air shutter lockscrew. Refer to *Figure 3* and *Figure 4*.
6. Turn the air shutter to the left to get a luminous yellow tipped flame, then turn it back slowly to the right to obtain a steady blue flame.
7. After proper flame is obtained, tighten air shutter lockscrew firmly. Refer to *Figure 3* and *Figure 4*.
8. Reinstall access panel and screws.

	WARNING
<p>To reduce the risk of fire or serious injury, the access panel must be in place during normal operation.</p>	
W262	

NOTE: After the dryer has operated for approximately three minutes, exhaust air or exhaust pipe should be warm.

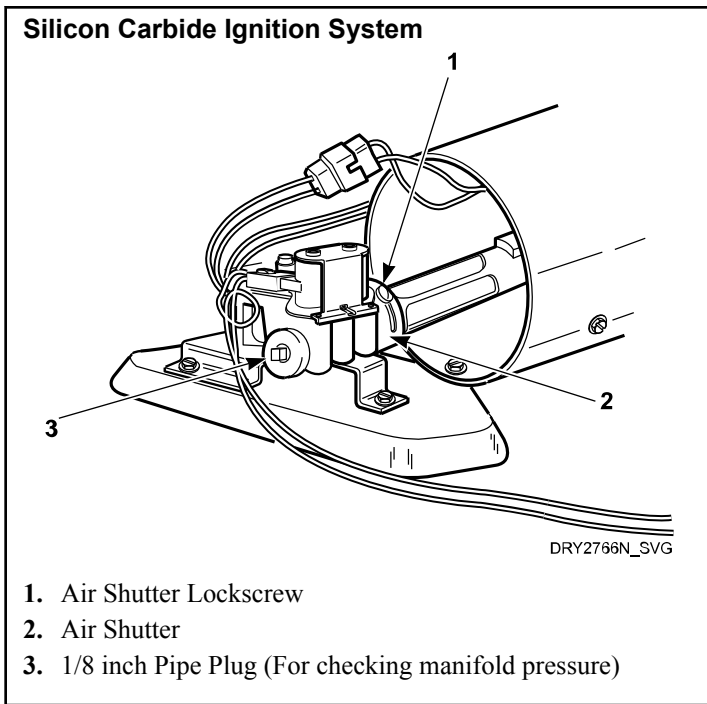

Figure 3

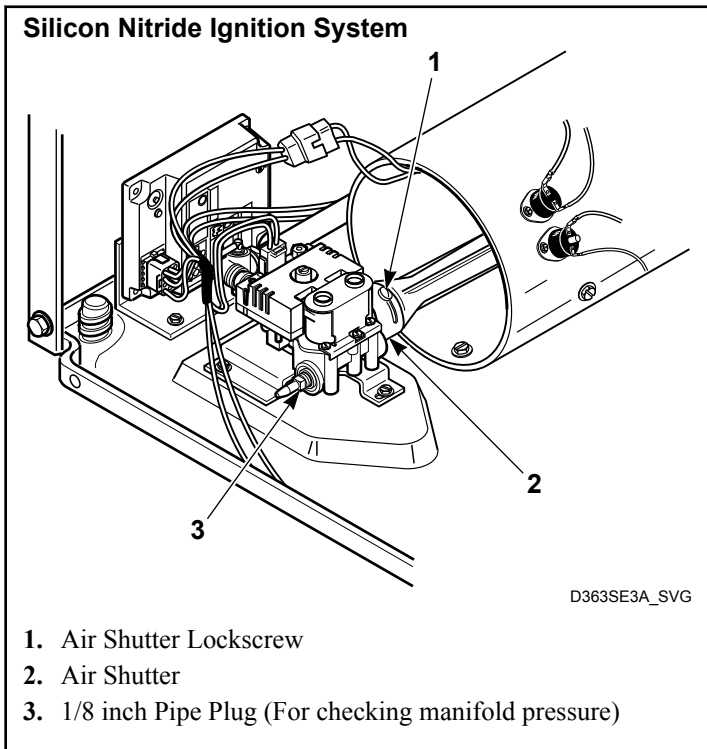



Figure 4

Test Procedures

	WARNING
<p>To reduce the risk of electric shock, fire, explosion, serious injury or death:</p> <ul style="list-style-type: none"> • Disconnect electric power to the dryer before servicing. • Close gas shut-of valve to gas dryer before servicing. • Never start the Dryer with any guards/panels removed. • Whenever ground wires are removed during servicing, these ground wires must be reconnected to ensure that the dryer is properly grounded. 	
W001R1	

IMPORTANT: Electrical test procedures in this service manual are performed by using a Volt-Ohm meter. Tests can also be performed using a multimeter or any other electrical testing equipment with which the service person is familiar.

Fabric Selector Switch

NOTE: Refer to proper model wiring diagram when re-wiring switch.

Set test meter to read Ohms and apply meter probes to switch terminals.

NOTE: Refer to proper model wiring diagram when reconnecting wires.

FABRIC SELECTOR SWITCH – 4 Position			
	L1-1	L1-2	
No Heat	–	–	
Delicate	X	X	
Perm. Press	–	X	
Regular	–	X	
X indicates closed			
FABRIC SELECTOR SWITCH – 3 Position			
	L1-2	L1-3	L1-1
No Heat	–	X	–
Delicate	X	–	X
Perm. Press/ Regular	X	–	–
X indicates closed			

Drive Motor

Refer to *Figure 5* .

1. Remove motor and exhaust assembly.
2. Disconnect motor wire harness at motor disconnect block.

NOTE: Refer to *Internal Wiring of Dryer Motor Switch* for wiring schematic.

Drive Motor Resistance:	
120 Volt	2,460 – 3,100 Ohms
240 Volt	10,000 - 13,000 Ohms
24 Volt	80 - 130 Ohms

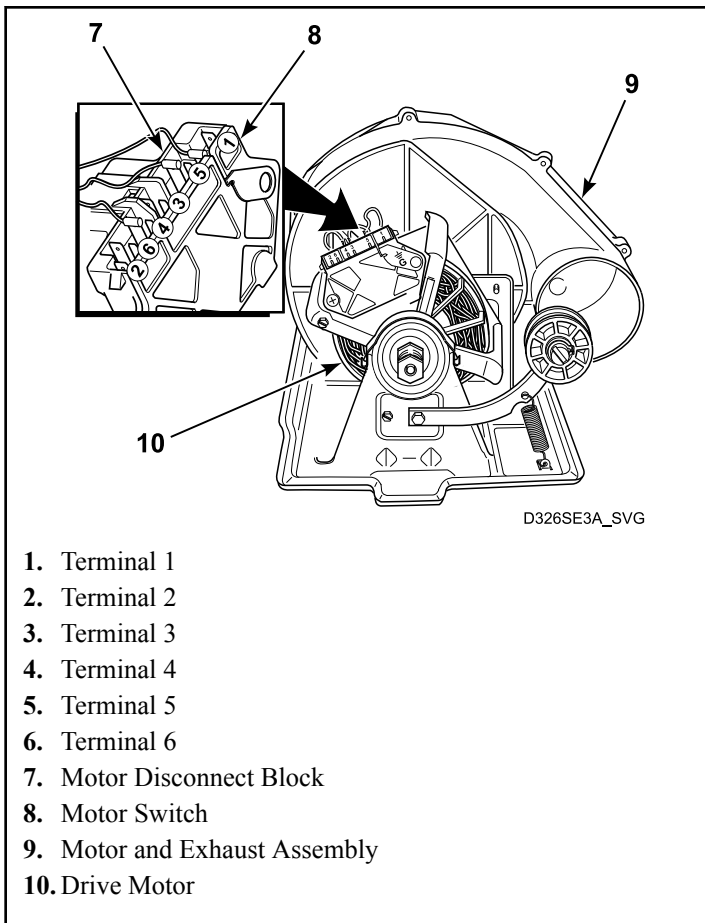

Figure 5

Drive Motor - Motor Switch

Refer to *Internal Wiring of Dryer Motor Switch* for wiring schematic.



WARNING

Disconnect electric power to dryer before performing any of the following steps or when replacing inoperative motor switch.

W290

NOTE: Disconnect terminal 5 wire (yellow or copper) from motor switch before testing start terminals.

NOTE: Reconnect terminal 5 wire (yellow or copper) to motor switch before testing run terminals.

NOTE: Unplug the motor wire harness from the motor connection block before starting this test.

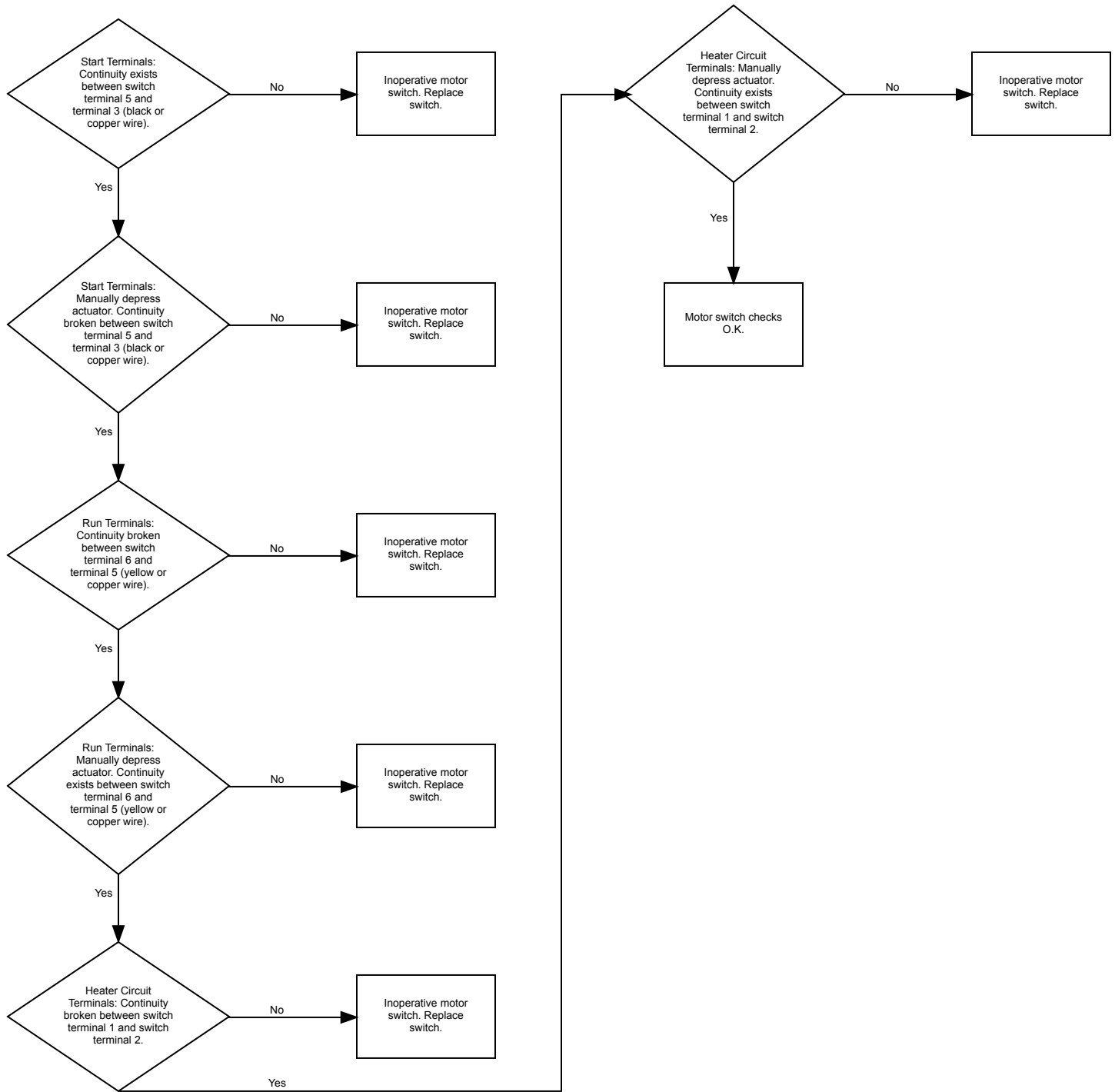

Drive Motor - Motor Windings

Refer to *Internal Wiring of Dryer Motor Switch* for wiring schematic.

	WARNING
<p>Disconnect electric power to dryer before performing any of the following steps or when replacing inoperative motor switch.</p>	
W290	

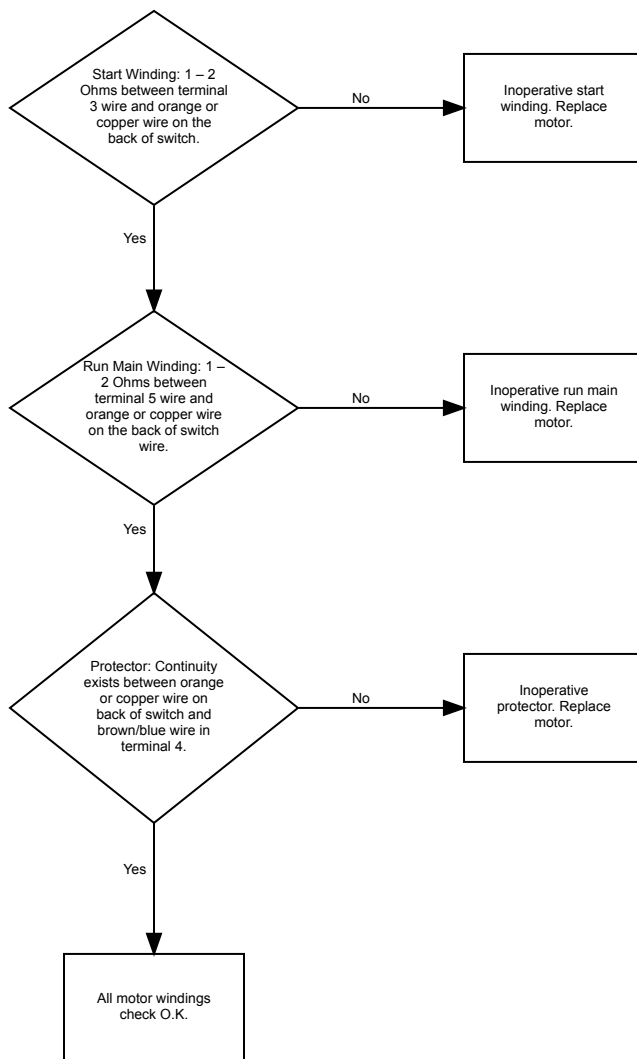

Motor Switch

1. Remove motor and exhaust fan assembly.
2. Remove the two motor switch attaching screws. Refer to *Figure 6*. Disconnect switch leads. Remove motor switch.
3. Remove thermal overload protector.

NOTE: The thermal overload protector is unique to the motor from which it was removed and should only be used on that motor. To reduce the risk of overheating the motor, do not use any thermal overload protector other than the one taken from the inoperative motor switch in step 3.

- a. **Motor with Switch on Blower End.** Using a small bladed screwdriver, press the thermal overload protector mounting tab downward and remove the thermal overload protector from the inoperative motor switch. Refer to *Figure 6*.

- b. **Motor with Switch on Pulley End.** Press the tip of a small bladed screwdriver into the slot located between top of motor switch and plastic clip. Lift up on handle of screwdriver until both clip and thermal overload protector detach from motor switch. Refer to *Figure 7*.
4. Attach the thermal overload protector removed in Step “3” to the new motor switch.
5. Install new motor switch onto motor and reconnect motor switch leads removed in Step “2”. Refer to *Figure 6*.
6. Test motor switch by following the step-by-step procedures. Refer to *Drive Motor*.
7. Before reinstalling the motor assembly, apply power (120 VAC) directly to motor terminals 4 and 5. Then start and run the motor at least 6 times, making sure the motor and switch are operating properly.

NOTE: The dryer manufacturer and parts suppliers are not liable for improper switch installation.

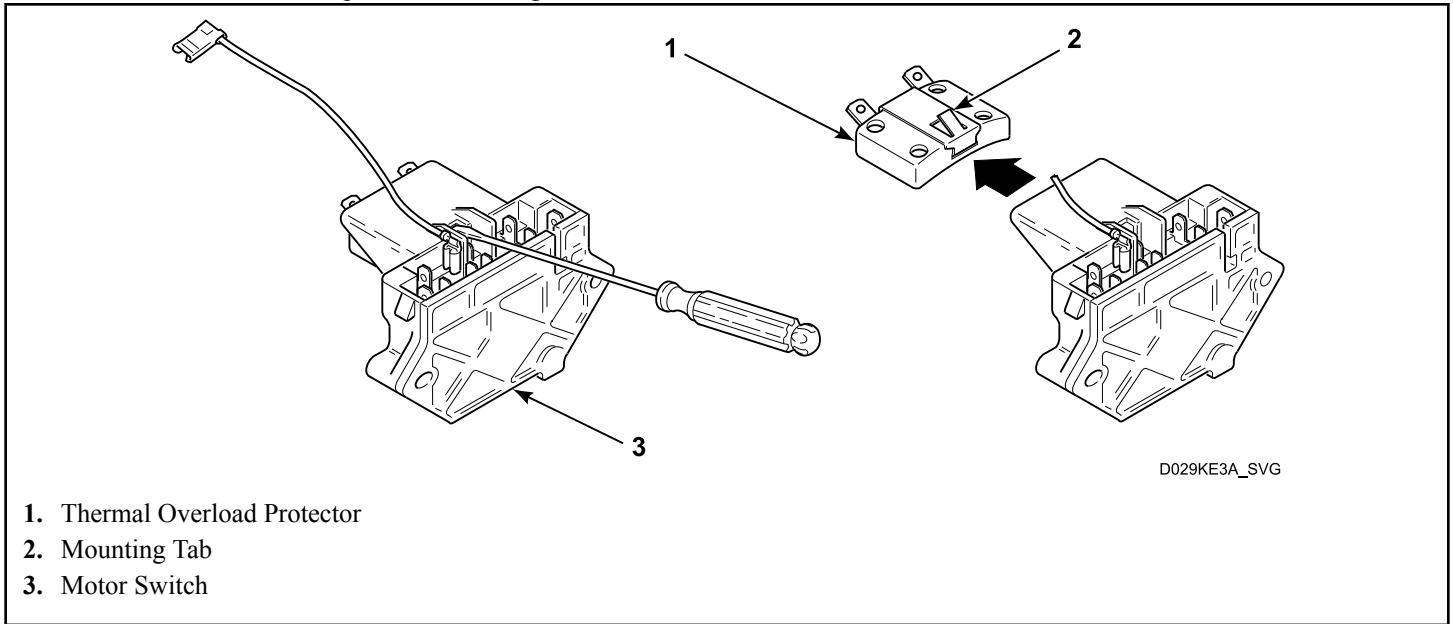

Figure 6

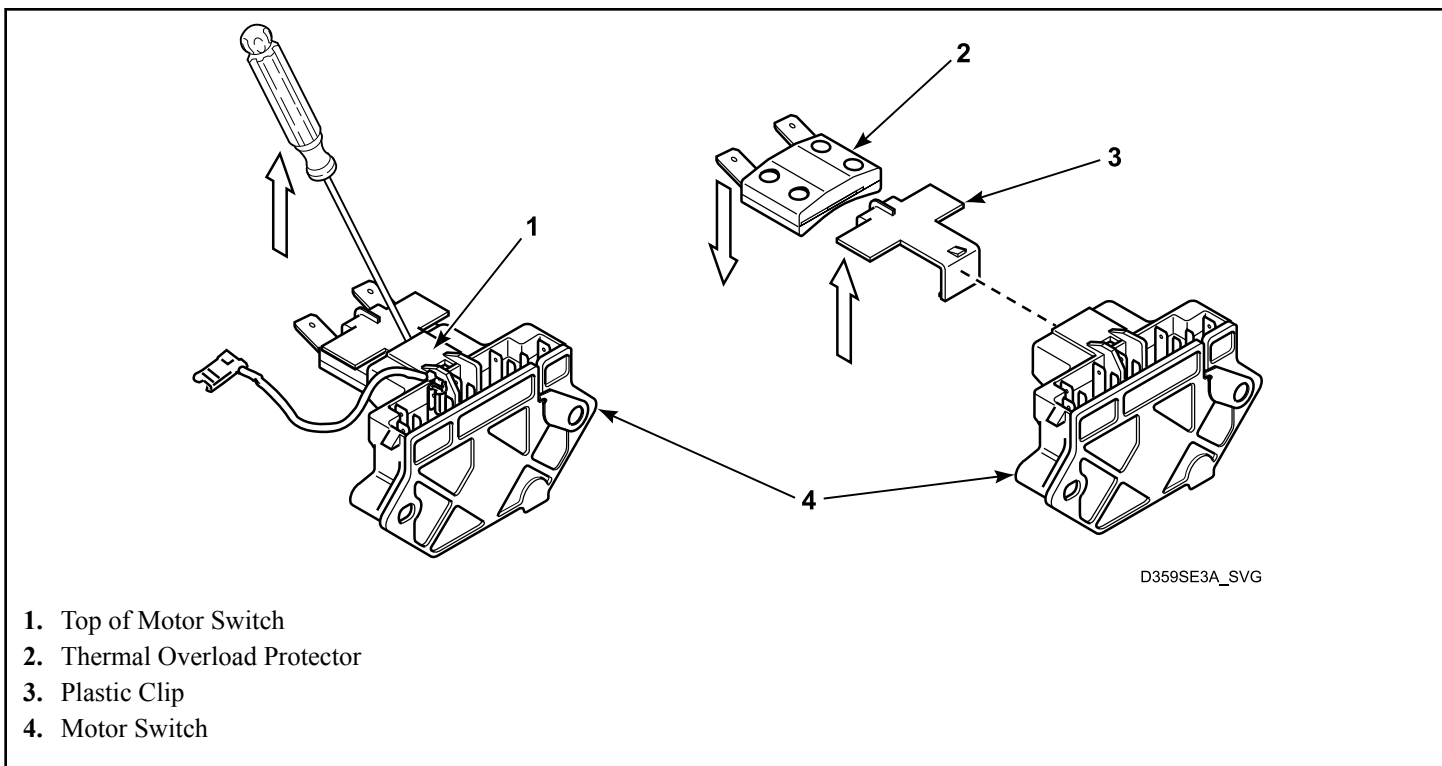

Figure 7

Burner System Operation - Gas Models

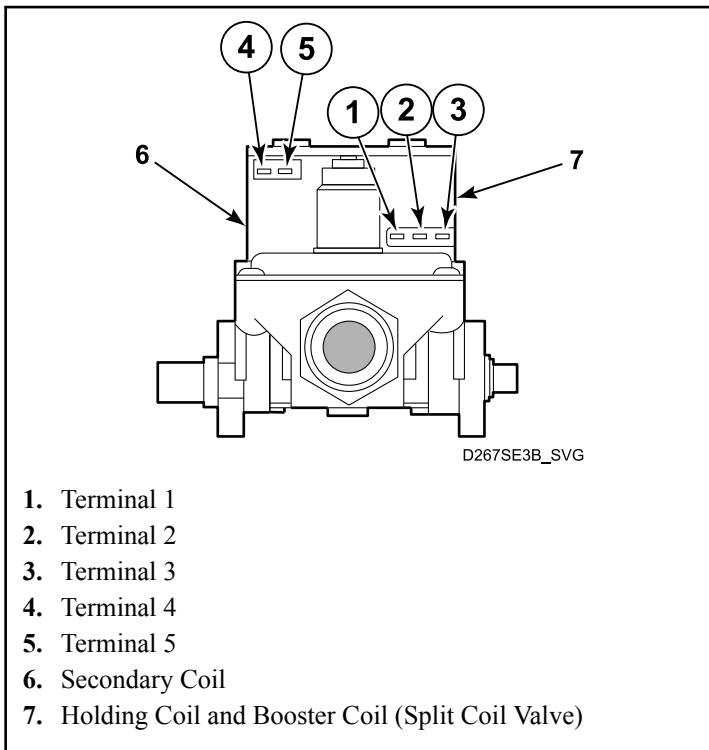

Figure 8

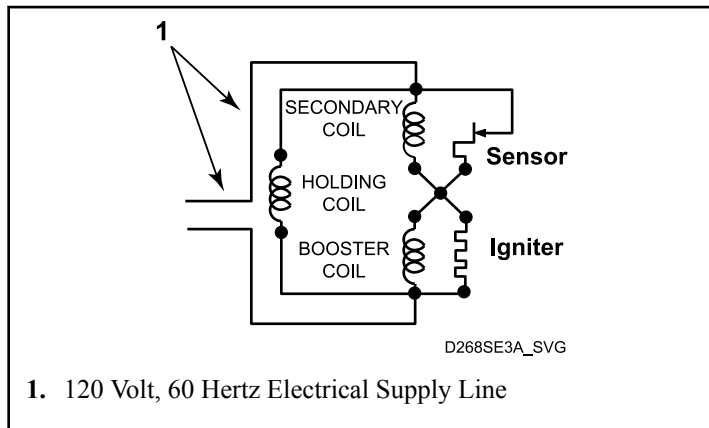
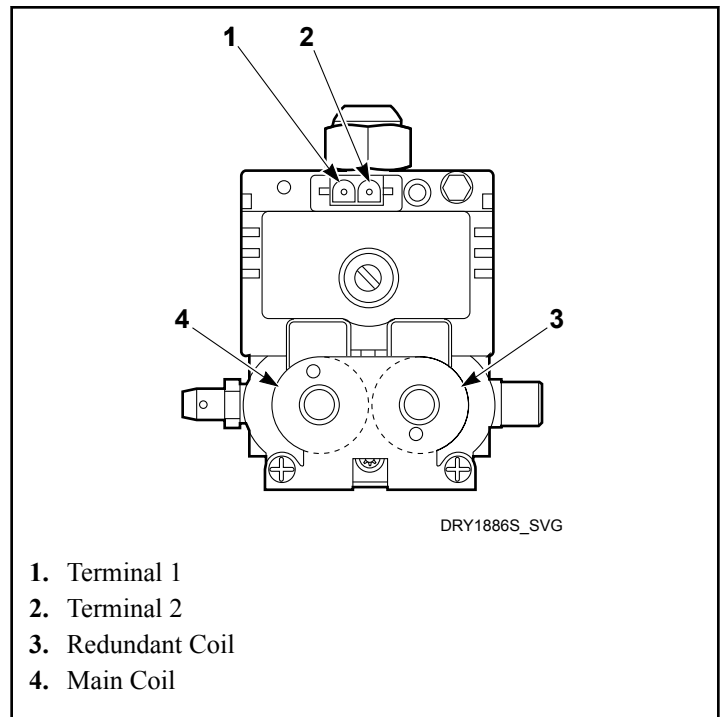

Figure 9

Gas Models - Refer to *Figure 8* and *Figure 9* .

1. **Components.** This burner has four basic components: a silicon carbide (glow bar) igniter, burner tube, sensor, and a two-stage gas valve consisting of a split-coil valve and a secondary coil valve. The split-coil valve is opened when the dryer thermostat calls for heat, while the secondary valve does not open until the igniter has attained ignition temperature.
2. **Pre-Ignition Circuits.** When the dryer thermostat calls for heat, circuits are completed through the holding coil, sensor, booster coil and igniter. Both coils must be energized to open the split-coil valve. Once opened, the holding coil can hold the valve open without assistance from the booster coil. The sensor triggers the current to travel around the secondary coil and through the igniter, causing the igniter to get hot.

3. **Burner Circuit.** In approximately 30 seconds, the igniter attains ignition temperature and ignition is made. The heat from the burner flame causes the sensor contacts (located on burner housing beside the igniter) to open. A circuit is then completed through the secondary valve coil, opening the valve and allowing gas to flow.
4. **Momentary Power Interruption.** Upon resumption of power, sensor contacts will still be open, permitting secondary valve to open. However, with the secondary coil in the circuit, the booster coil cannot draw enough current to open the split-coil valve. When sensor contacts do reclose, the secondary valve will close, and the burner system will be in the normal pre-ignition circuit.
5. **Flame Failure.** In case of flame failure, the sensor contacts will re-close in about 45 seconds. This will close the secondary valve and the burner system will be in the normal pre-ignition circuit.
6. **Ignition Failure.** If flame is not established as sensor contacts open, secondary valve will remain open until sensor contacts re-close. Sensor will continue to recycle the igniter and secondary valve (about once per minute) until ignition is made or dryer is turned off.



1. Terminal 1
2. Terminal 2
3. Redundant Coil
4. Main Coil

Figure 11

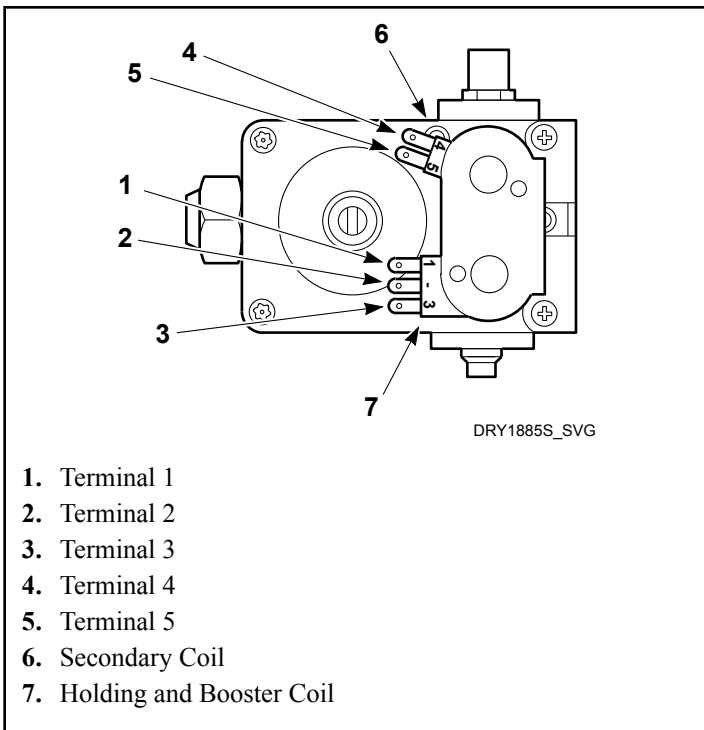

1. Terminal 1
2. Terminal 2
3. Terminal 3
4. Terminal 4
5. Terminal 5
6. Secondary Coil
7. Holding and Booster Coil

Figure 10

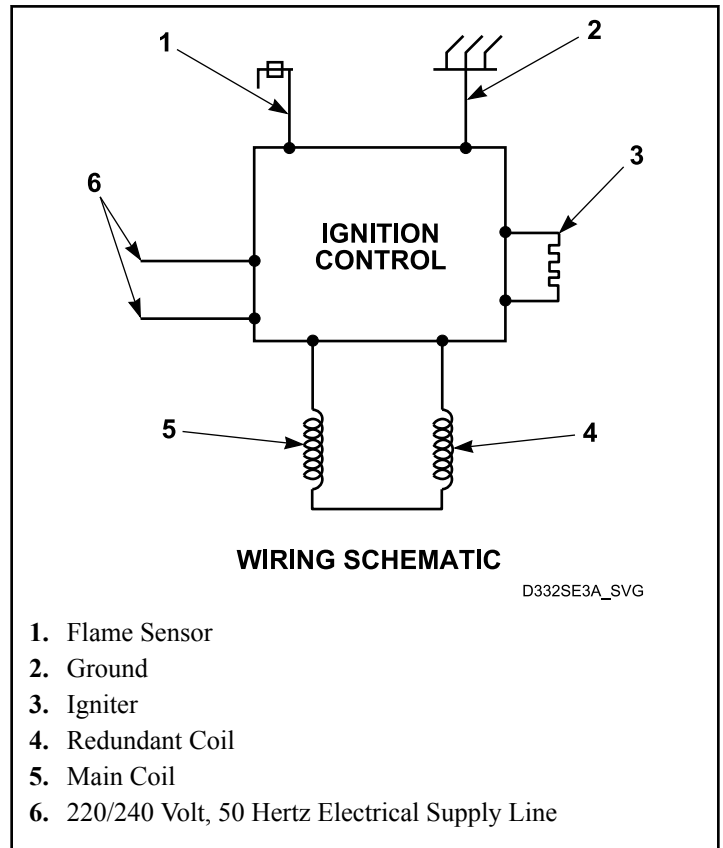

1. Flame Sensor
2. Ground
3. Igniter
4. Redundant Coil
5. Main Coil
6. 220/240 Volt, 50 Hertz Electrical Supply Line

Figure 12

Electrical Circuit To Ignition System (Gas Models)

1. While supporting the access panel, remove two screws from bottom edge of access panel.
2. Gently lower the access panel to disengage locators from bottom edge of front panel.
3. Close main gas shut-off valve. Refer to *Figure 3* and *Figure 4*.
4. Remove valve wire harness disconnect block from the holding and booster coil. Refer to *Figure 10* and *Figure 11*.
5. Plug dryer power cord into wall receptacle, and start the dryer in a heat setting (refer to dryer Operating Instructions).
6. Set test meter to read AC voltage and apply meter probes into terminals on the dryer harness plug that would correspond to terminals “1” and “2” on the coil. Refer to *Figure 8* and *Figure 9*. Meter should register line voltage in all temperature settings, except NO HEAT which should read “zero” VAC.
7. If meter does not read line voltage in step “f”, check motor switch, thermostats, fabric switch, or control.

Coil Tolerance Readings		
Holding Coil – Terminals 1 & 2	1700 ± 285 Ohms	1365 ± 230 Ohms
Booster Coil – Terminals 1 & 3	685 ± 115 Ohms	560 ± 100 Ohms
Secondary Coil – Terminals 4 & 5	1680 ± 285 Ohms	1325 ± 230 Ohm

Table 4

Silicon Nitride Ignition: Both coils should read between 2400-2800 Ohms.

NOTE: If meter registers any other readings than those listed above, the respective coil(s) should be replaced.

Sensor Check (Gas Models)

1. While supporting the access panel, remove two screws from bottom edge of access panel.
2. Gently lower the access panel to disengage locators from bottom edge of front panel.
3. Close main gas shut-off valve. Refer to *Figure 3* and *Figure 4*.
4. Remove wires from sensor terminals.
5. Set test meter to read Ohms and put meter probes on sensor terminals. Meter should read “zero” Ohms. If meter registers an Ohm reading of any amount, replace sensor.

	WARNING
<p>To reduce the risk of fire, explosion and electric shock, close the valve in the gas supply line to the gas dryer and disconnect the electrical power unless gas or power supplies are required to perform test procedure.</p>	
W263	

Gas Valve Coils Check (Gas Models)

1. While supporting the access panel, remove two screws from bottom edge of access panel.
2. Gently lower the access panel to disengage locators from bottom edge of front panel.
3. Close main gas shut-off valve. Refer to *Figure 3* and *Figure 4*.
4. Remove disconnect blocks from gas valve coils.
5. Set test meter to read Ohms and put meter probes to terminals shown in *Figure 10*, *Figure 11*, *Figure 12*, and in the following chart.

Silicon Carbide Ignition:

Coil Tolerance Readings		
Meter probes to terminals:	Meter should read:	
	50 Hertz	60 Hertz

Table 4 continues...

Igniter Check - Gas Models

1. While supporting the access panel, remove two screws from bottom edge of access panel.
2. Gently lower the access panel to disengage locators from bottom edge of front panel.
3. Close main gas shut-off valve. Refer to *Figure 3* and *Figure 4*.
4. Disconnect igniter wires at disconnect block.
5. Set test meter to read Ohms and put meter probes on terminals of igniter wires.
6. **Silicon Carbide Igniter:** Meter should read between 45 – 200 Ohms. **Silicon Nitride Igniter:** Meter should read between 49 – 88 Ohms.

NOTE: If meter does not read appropriate Ohms, then replace the igniter.

IMPORTANT: Always examine all wires, terminals and connectors to be sure wiring is correct before replacing any components.

Ignition Control Grounding Check - Silicon Nitride Ignition

1. While supporting the access panel, remove two screws from bottom edge of access panel.
2. Gently lower the access panel to disengage locators from bottom edge of front panel.
3. Close main gas shut-off valve. Refer to *Figure 3* and *Figure 4*.
4. Remove wires from sensor terminals.
5. Set test meter to read Ohms and put meter probes on the ground wire connection in 12-pin block (connected to module) and on the green ground screw in base of dryer.
6. Meter should read “zero” Ohms. If meter registers an Ohm reading of any amount, check ground wire connection and replace as necessary.

White	4.75	208 V 60 Hz.	8.2 ± .5 Ohms Cold
Green	4.8	240 V 50 Hz.	10.75 ± .32 Ohms Cold
Yellow	4	240 V 50 Hz.	13.03 ± .39 Ohms Cold
Blue	3.1	240 V 50 Hz.	16.7 ± .5 Ohms Cold
Orange	5.35	240 V 60 Hz.	9.72 ± .3 Ohms Cold
Purple	4.25	208 V 60 Hz.	9.27 ± .3 Ohms Cold

Thermal Fuse (Electric Models)

1. While supporting the access panel, remove two screws from bottom edge of front access panel.
2. Gently lower the access panel to disengage panel locators from bottom edge of front panel.
3. Label and disconnect wires from thermal fuse.
NOTE: Refer to wiring diagram when rewiring thermal fuse.
4. Set multimeter to read Ohms. Apply meter probes to thermal fuse terminals. Multimeter should read 0 Ohms. If the meter does not show any reading (infinite Ohms), then the fuse is open. If the fuse is open, then replace BOTH the thermal fuse and the limit thermostat.

Heater Assembly (Electric Models)

1. While supporting the access panel, remove two screws from bottom edge of access panel.
2. Gently lower the access panel to disengage panel locators from bottom edge of front panel.
3. Disconnect wires from heater assembly.
NOTE: Refer to wiring diagram when rewiring heater assembly.
4. Set meter to read Ohms. Apply meter probes to the heater assembly terminals. Meter should read as follows: (Cold Ohms).

Heater Element Color Code	KW	Voltage/Hz.	Resistance Reading
Red	5	240 V 60 Hz.	10.39 ± .31 Ohms Cold

Table continues...

Cycling or Limit Thermostat

1. While supporting the access panel, remove two screws from bottom edge of access panel.
2. Gently lower the access panel to disengage panel locators from bottom edge of front panel.
3. Label and disconnect wires from thermostat.
NOTE: Refer to wiring diagram when rewiring thermostat.
4. **Cycling Thermostat (S.P.S.T. – 2 Terminals) or Limit Thermostat**
 - a. Set meter to read Ohms.
 - b. Apply meter probes to the thermostat terminals.
 - c. Meter should read “zero.”
5. **Cycling Thermostat (S.P.D.T. – 3 Terminals)**
 - a. Set meter to read Ohms.
 - b. Apply meter probes to terminals 1 and 3. Meter should read “zero”.
 - c. Remove screws holding thermostat to blower fan cover.
 - d. Heat thermostat with a small flame until a distinct “click” is heard, then immediately apply meter probes to terminals 1 and 2. Meter should read “zero”.

Door Switch

1. While supporting the access panel, remove two screws from bottom edge of access panel.
2. Gently lower the access panel to disengage locators from bottom edge of front panel.
3. Remove two screws holding bottom tabs on front panel to dryer side panels. Swing bottom of front panel away from dryer far enough to disengage hold-down clips and locators from cabinet top.
4. Disconnect wires from door switch.
NOTE: Refer to model wiring diagram when rewiring door switch.

5. Set meter to read Ohms and apply meter probes on switch terminals 1 and 3 with door closed. You should get “zero” reading.
6. Apply probes to terminals 1 and 2 with door closed. The meter should read “infinite”.
7. Open door. Meter should read “infinite” between 1 and 3 and “zero” between 1 and 2.

Thermistor

1. While supporting the access panel, remove two screws from bottom edge of access panel.
2. Gently lower the access panel to disengage panel locators from bottom edge of front panel.
3. Label and disconnect wires from thermistor.

NOTE: Refer to wiring diagram when rewiring thermistor.

4. Set meter to read Ohms.
5. Apply meter probes to the thermistor terminals.
6. Meter should read that resistance is present (thermistor is not open).

Internal Wiring of Dryer Motor Switch



WARNING

To reduce the risk of electric shock, fire, explosion, serious injury or death:

- Disconnect electric power to the dryer before servicing.
- Close gas shut-of valve to gas dryer before servicing.
- Never start the Dryer with any guards/panels removed.
- Whenever ground wires are removed during servicing, these ground wires must be reconnected to ensure that the dryer is properly grounded.

W001R1

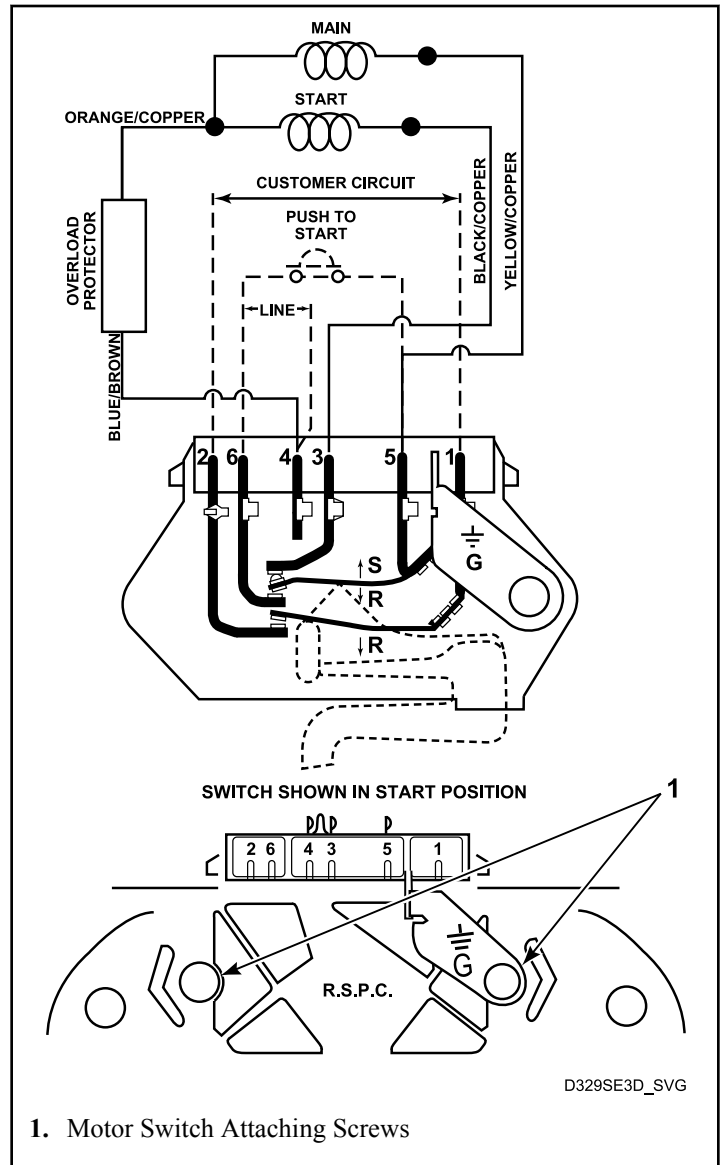

Figure 13